

VARIANCES & WAIVERS REQUESTED

1. A VARIANCE FROM 5.7.1 IS REQUESTED TO REDUCE THE FORM DISTRICT TRANSITION ZONE FRONT YARD FROM 25 FEET TO 4.30 FEET TO ALLOW ENCROACHMENT OF PROPOSED ADDITION.
2. A VARIANCE FROM 5.7.1 IS REQUESTED TO REDUCE THE FORM DISTRICT TRANSITION ZONE STREET SIDE YARD FROM 25 FEET TO 0 FEET TO ALLOW ENCROACHMENT OF EXISTING BUILDING.
3. A VARIANCE FROM 5.7.1 IS REQUESTED TO REDUCE THE FORM DISTRICT TRANSITION ZONE REAR YARD FROM 25 FEET TO 5 FEET TO ALLOW ENCROACHMENT OF PROPOSED ADDITION.
4. A VARIANCE FROM 5.7.1 IS REQUESTED TO REDUCE THE FORM DISTRICT TRANSITION ZONE SIDE YARD FROM 5 FEET TO 0 FEET TO ALLOW ENCROACHMENT OF EXISTING BUILDING AND PROPOSED ADDITION.
5. A WAIVER FROM 5.5.3.a TO ALLOW PARKING IN THE FRONT YARD.
6. A WAIVER FROM 5.6.1.c TO ALLOW REAR AND SIDE FACADE OF EXISTING BUILDING TO HAVE SAME LEVEL OF DETAIL AS FACADES FACING PRESTON HIGHWAY AND LINWOOD AVENUE.
7. A WAIVER FROM TABLE 10.2.3 TO REQUIRE PROPERTY PERIMETER LBA ALONG ADJOINING RESIDENTIAL PROPERTY LINES.
8. A WAIVER FROM 10.2.10 TO REQUIRE 5 FT. BUFFER ALONG RESIDENTIAL HOMES ADJACENT TO THE DEVELOPMENT.
9. A WAIVER FROM 10.2.10 TO REQUIRE VUA/LBA ALONG PRESTON HIGHWAY AND LINWOOD AVENUE.

NOTES

1. CONSTRUCTION PLANS AND DOCUMENTS SHALL COMPLY WITH LOUISVILLE AND METROPOLITAN SEWER DISTRICT'S DESIGN MANUAL AND STANDARD SPECIFICATIONS
2. THESE TRACTS ARE NOT LOCATED WITHIN THE 100 YEAR FLOODPLAIN PER FIRM MAP 21111C0058 F, DATED FEBRUARY 26, 2021.
3. MSD SANITARY SEWERS ARE EXISTING AND AVAILABLE.
4. MITIGATION MEASURES FOR DUST CONTROL SHALL BE IN PLACE DURING CONSTRUCTION TO PREVENT FUGITIVE PARTICULATE EMISSIONS FROM REACHING EXISTING ROADS AND NEIGHBORING PROPERTIES.
5. ALL ROADWAY AND ENTRANCE INTERSECTIONS SHALL MEET THE REQUIREMENTS FOR LANDING AREAS AS SET BY METRO PUBLIC WORKS.
6. KENTUCKY TRANSPORTATION CABINET REVIEW REQUIRED AND COMMENTS MUST BE ADDRESSED PRIOR TO APPROVAL BY MPW.
7. COMPATIBLE UTILITIES SHALL BE PLACED IN A COMMON TRENCH UNLESS OTHERWISE REQUIRED BY APPROPRIATE AGENCIES.
8. VERGE AREAS WITHIN PUBLIC RIGHT-OF-WAY TO BE PROVIDED PER MPW (TABLE 6.2.1)
9. DUMPSTER WILL BE SCREENED PER LDC SECTION 5.5.2.B.2.
10. ANY PROPOSED SIGNS SHALL BE IN COMPLIANCE WITH CHAPTER 8 OF THE LOUISVILLE METRO LAND DEVELOPMENT CODE AND APPLICABLE ORDINANCES.
11. THE THREE TRACTS IN THIS DEVELOPMENT PLAN WILL CONSOLIDATED BEFORE BUILDING CONSTRUCTION CAN COMMENCE.
12. A LANDSCAPE PLAN SHOWING THE LOCATION OF STREET TREES MUST BE SUBMITTED AND APPROVED BEFORE CONSTRUCTION PLANS CAN BE APPROVED.

EROSION PREVENTION AND SEDIMENT CONTROL NOTES

The approved erosion prevention and sediment control (EPSC) plan shall be implemented prior to any land disturbing activity on construction site. Any modifications to the approved EPSC plan must be reviewed and approved by MSD's Private Development Review office. EPSC BMP's shall be installed per the plan and MSD standards. Detention basins, if applicable, shall be constructed first and shall perform as a sediment basin during construction until the contributing drainage areas are seeded and stabilized. Actions must be taken to minimize the tracking of mud and soil from construction areas onto public roadways. Soil tracked onto the roadway shall be removed daily. Soil stockpiles shall be located away from streams, ponds, swales and catch basins. Stockpiles shall be seeded, mulched and adequately contained through the use of silt fence. All stream crossings must utilize low-water crossing structures per MSD Standard Drawing ER-02. Where construction or land disturbance activity will or has temporarily ceased on any portion of a site, temporary site stabilization measures shall be required as soon as practicable, but no later than 14 calendar days after the activity has ceased. Sediment-laden groundwater encountered during trenching, boring or other excavation activities shall be pumped to a sediment-trapping device prior to being discharged into a stream, pond, swale or catch basin. The Contractor shall be responsible for inspection and if necessary, cleaning the Temporary Sediment Basin located at the detention facility. The required inspections shall be accomplished in a timely manner every thirty (30) calendar days after construction begins and shall continue until vegetation is established.

WAVE STYLE BIKE RACK - HEAVY DUTY
MODEL 543-1002 (PARKS 5 BIKES)
THE PARK CATALOG AND FACILITIES
(OR EQUIVALENT)

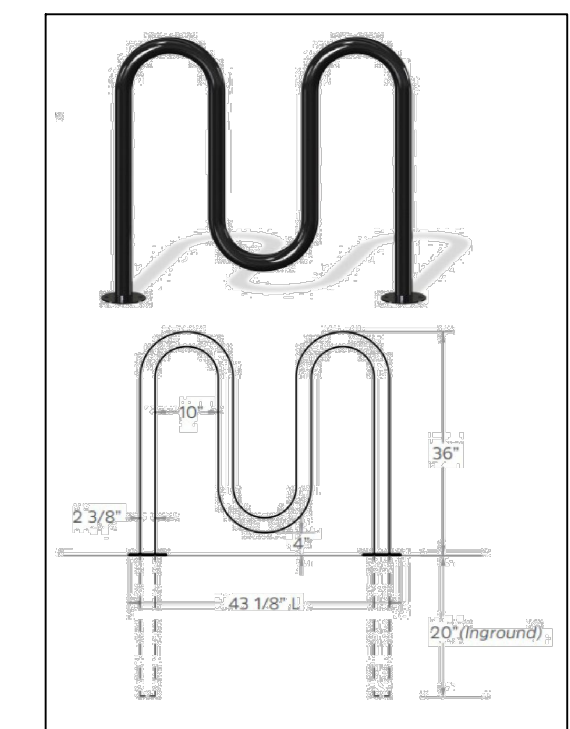

VICINITY MAP

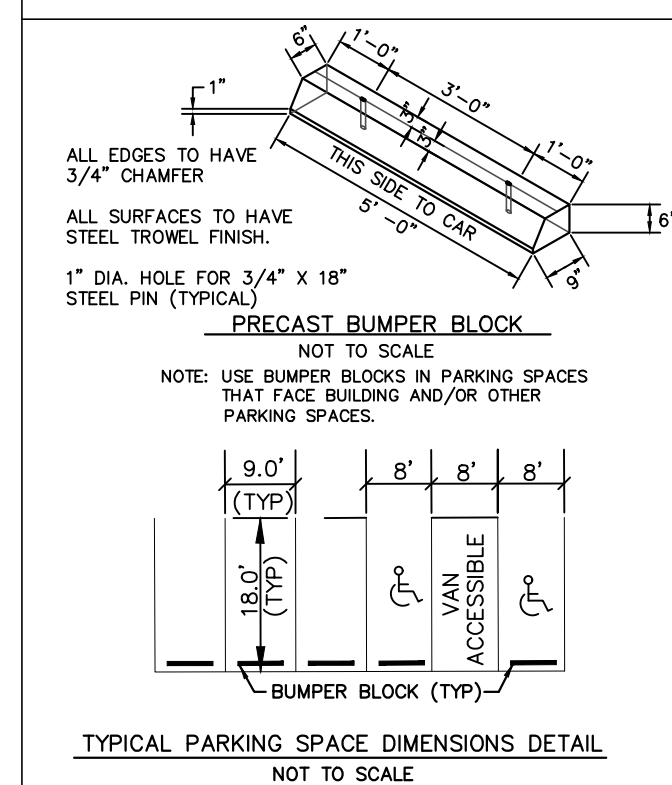

REVISIONS:

- 8-22-22 AGENCY COMMENTS
- 10-11-22 REVISED STAIRS-LINWOOD
- 10-13-22 ADDED STREET TREES

DRWN BY: mse
DRAWING NAME: CAT2B.DWG
PLOT NAME: PLAN

Michael S. Evans, P.E., P.L.S.
Civil Engineer & Land Surveyor
6625 Colonial Avenue
Evansville, Indiana 47725
(502) 593-9430
mikeevans593943@yahoo.com

**PROPOSED RETAIL + RESIDENTIAL ADDITION
2703, 2705 + 2707 PRESTON HIGHWAY**

**CATEGORY 2B DEVELOPMENT PLAN
VARIANCE REQUEST PLAN**

DATE: 7-01-22
PROJECT NO.: XXXXX

