

NOTES:

1. THE PURPOSE OF THIS PLAT IS TO CLOSE (2) ALLEYS.
2. THIS SITE DOES NOT LIE WITHIN A 100 YEAR FLOOD HAZARD ELEVATION. PER FEMA'S FIRM MAPPING (21111C0027E).
3. THIS PLAT IS SUBJECT TO EASEMENTS AND RESTRICTIONS WHETHER RECORDED OR NOT.

LEGEND

- AREA TO BE CLOSED
0.18 ACRES 8085.5 SQ. FT.
- SET 5/8"x18" REBAR WITH CAP #4011
- FOUND IRON PIN WITH CAP #3890

ACREAGE COMPUTATION

- LOT 1**
MIN: 130,521.57 SQ. FT.
2.996 ACRES
MAX: 133,568.50 SQ. FT.
3.066 ACRES
- LOT 2**
MIN: 20,233.14 SQ. FT.
.464 ACRES
MAX: 23,439.50 SQ. FT.
.538 ACRES
- LOT 3**
MIN: 27,047.34 SQ. FT.
.621 ACRES
MAX: 28,515.11 SQ. FT.
.655 ACRES
- LOT 4**
MIN: 21,319.14 SQ. FT.
.489 ACRES
MAX: 22,309.59 SQ. FT.
.512 ACRES
- LOT 5**
MIN: 2,103.69 SQ. FT.
.048 ACRES
MAX: 2,225.58 SQ. FT.
.051 ACRES

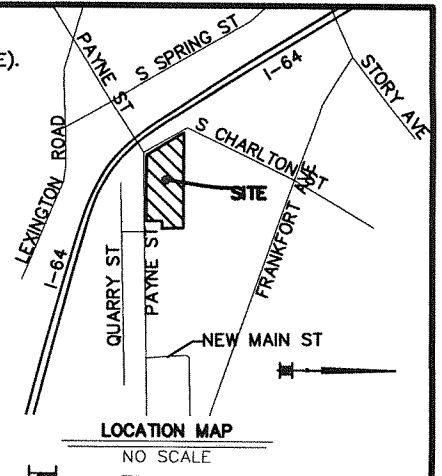

GRID NORTH

ALL OR PART OF THIS URBAN SURVEY SHOWN HEREON WAS CONDUCTED UTILIZING A TRIMBLE SERIES GLOBAL POSITIONING SYSTEM RECEIVER, MAKING FIELD OBSERVATIONS VIA THE (RTK) REAL TIME KINETIC, MULTI DERIVATION METHOD, IN CONJUNCTION WITH THE (KYTC) BASE, AND VRS BROADCAST SYSTEM. US STATE PLANE KENTUCKY NORTH ZONE, NAD83, NAVD88, GEOID US12A, A POSITIONAL ACCURACY OF 95% WAS ACHIEVED AND VERIFIED TO EXISTING FIRST ORDER HARN GEODETIC CONTROL NETWORK MONUMENTS.

LINE TABLE

LINE	BEARING	DISTANCE
L1	N 01°55'26" W	213.20'
L2	N 89°57'07" W	100.06'
L3	N 01°55'26" W	27.99'
L4	N 89°57'05" W	100.06'
L5	S 00°02'55" W	175.31'
L6	N 89°57'25" W	12.00'
L7	S 00°02'55" W	180.31'
L8	S 89°57'05" E	12.00'
L9	N 89°57'25" W	150.00'
L10	S 00°02'55" W	180.33'
L11	S 89°57'05" E	150.00'
L12	S 89°57'05" E	668.51'
L13	S 33°00'47" E	215.09'
L14	N 89°57'05" W	779.64'
L15	S 33°00'47" E	190.08'
L16	N 89°57'05" W	167.29'
L17	S 33°00'47" E	98.55'
L18	N 56°52'37" E	140.20'
L19	N 00°02'55" E	10.00'
L20	N 89°57'13" W	143.61'
L21	N 01°55'26" W	4.83'
L22	S 89°53'47" E	6.23'
L23	S 00°01'29" W	5.17'
L24	N 56°52'37" E	7.50'
L25	S 33°00'47" E	20.09'
L26	N 89°51'06" W	8.96'
L27	N 89°57'05" W	8.95'
L28	S 33°00'47" E	194.98'
L29	S 01°55'26" E	9.99'
L30	N 89°53'47" W	100.06'
L31	N 01°55'26" W	10.09'
L32	S 00°02'55" W	10.17'
L33	N 89°57'07" W	12.00'
L34	S 00°02'55" W	10.16'
L35	N 01°55'26" W	4.85'
L36	N 89°53'47" W	81.83'
L37	S 01°55'26" E	10.08'
L38	N 89°56'56" E	8.94'
L39	N 89°57'05" W	8.95'
L40	N 01°55'26" W	10.09'
L41	N 00°02'55" E	10.00'

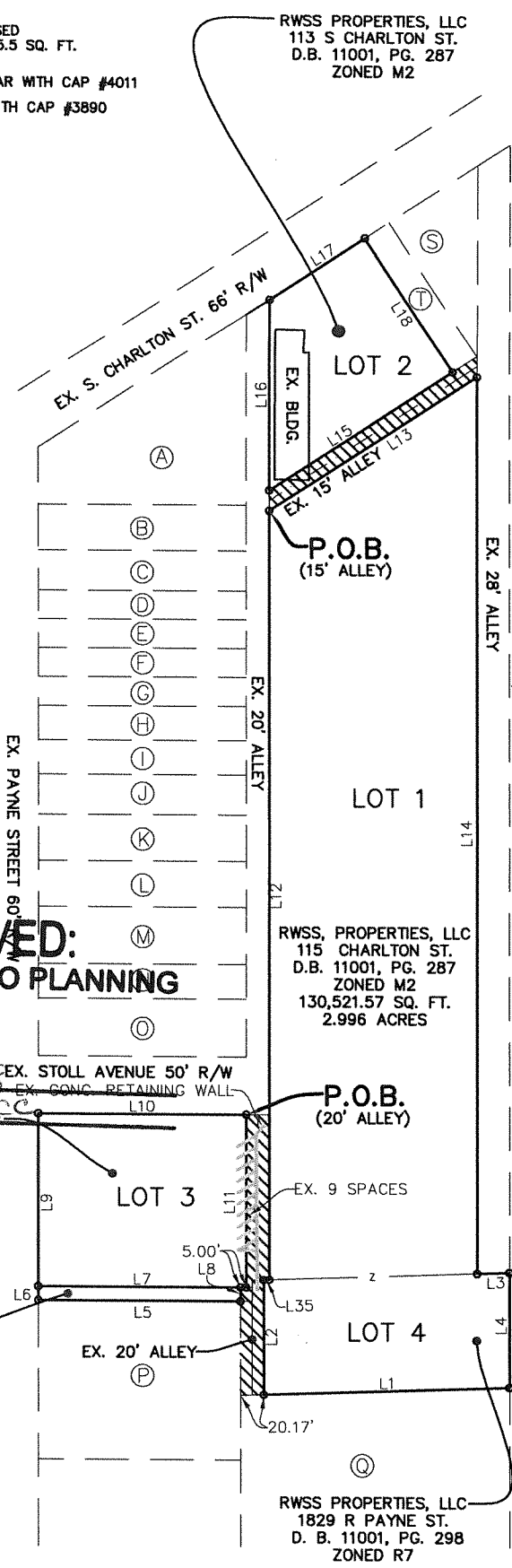

APPROVED:
LOUISVILLE METRO PLANNING COMMISSION

DATE *May 24, 2018*
BY *Joel Dock*
DOUGHERTY REALTY GROUP, LLC
1801 PAYNE ST.
D.B. 8591, PG. 472
ZONED OR3

LOT 5
DOUGHERTY REALTY GROUP, LLC
PAYNE ST.
D.B. 8591, PG. 472
ZONED R7

RWSS, PROPERTIES, LLC
115 CHARLTON ST.
D.B. 11001, PG. 287
ZONED M2
130,521.57 SQ. FT.
2.996 ACRES

RWSS PROPERTIES, LLC
1829 R PAYNE ST.
D. B. 11001, PG. 298
ZONED R7

STATE OF KENTUCKY
JOSHUA S. CALICO
4011
LICENSED PROFESSIONAL LAND SURVEYOR

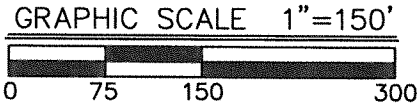

LAND SURVEYOR'S CERTIFICATE

I HEREBY CERTIFY THAT THE SURVEY AS DEPICTED HEREON WAS PERFORMED BY PERSONS UNDER MY DIRECT SUPERVISION, AND MEETS OR EXCEEDS THE MINIMUM TECHNICAL STANDARDS FOR AN URBAN SURVEY AS ESTABLISHED BY THE COMMONWEALTH OF KENTUCKY, PER 201 KAR 18:150 AND IN EFFECT ON THE DATE 05/10/16 THAT THIS SURVEY WAS COMPLETED IN THE FIELD.

Josh Calico 3/6/18
JOSHUA S. CALICO PLS# 4011 DATE:
NOT VALID WITHOUT ORIGINAL SIGNATURE AND SEAL OF THE PROFESSIONAL SURVEYOR

MINDEL, SCOTT & ASSOCIATES, INC.
PLANNING • ENGINEERING • SURVEYING LANDSCAPE ARCHITECTURE
5151 Jefferson Boulevard Louisville, Kentucky 40219 (502) 485-1508

ALLEY CLOSURE PLAT

OWNERS:
RWSS PROPERTIES, LLC
(PLAT LOTS-1,2 & 4)
D.B. 11001, PG.'S 287 & 298
115 CHARLTON ST., 113 S CHARLTON ST.
& 1829 R PAYNE ST.
LOUISVILLE, KENTUCKY 40206
TAX BLOCK 070A, LOTS 38,42 & 52

OWNERS:
DOUGHERTY, REALTY GROUP LLC
(PLAT LOTS-3&5)
D.B. 8591, PG. 472
1801 PAYNE ST. & PAYNE ST.
LOUISVILLE, KENTUCKY 40206
TAX BLOCK 070A, LOTS 22 & 21-SUBLOT 22

FORM DIST: TRADITIONAL NEIGHBORHOOD
ZONED: M2, OR3, R5A & R7
DATE: 3-5-18
SCALE: 1"=150'

L:\land projects\2\3363\Advanced Business Solutions\DWG\PLAT\ROAD CLOSURE\3363-RC.dwg, 3/6/2018 1:27:33 PM, \server1\SHARP.MX-2615N.PCL6

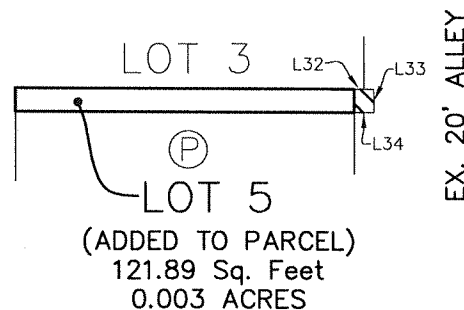
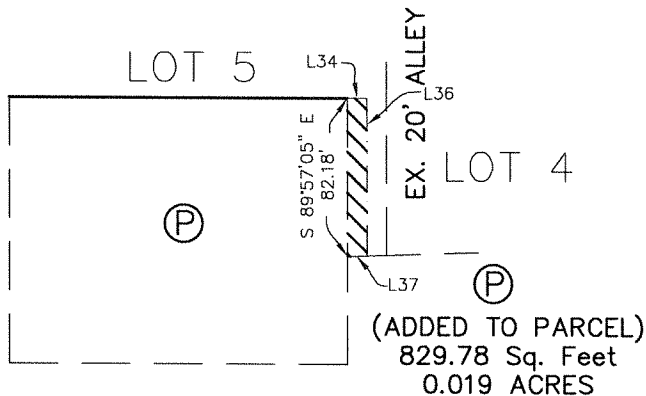
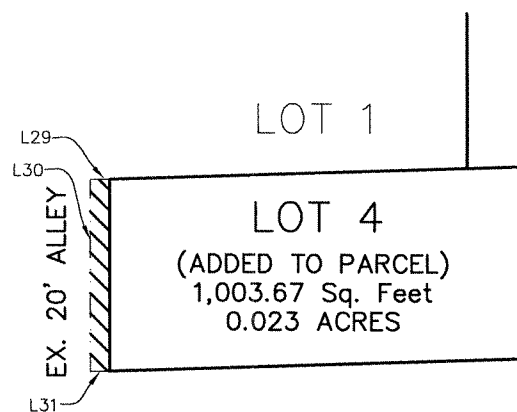
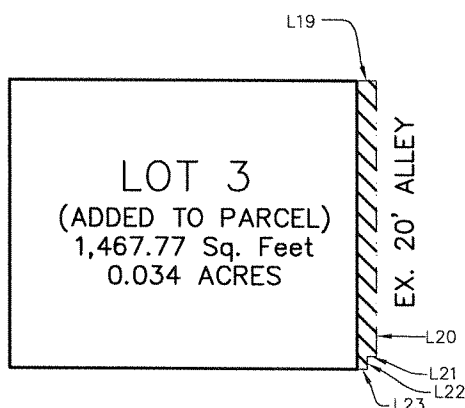
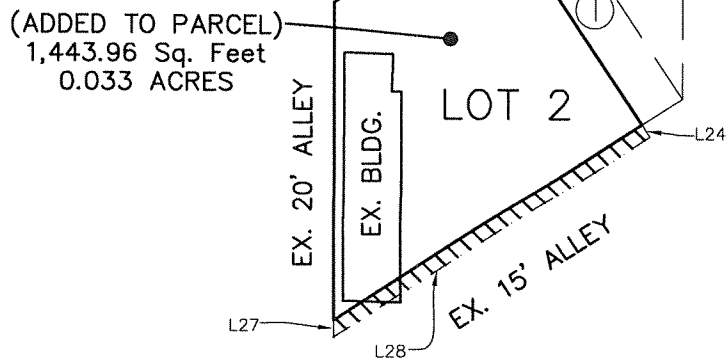
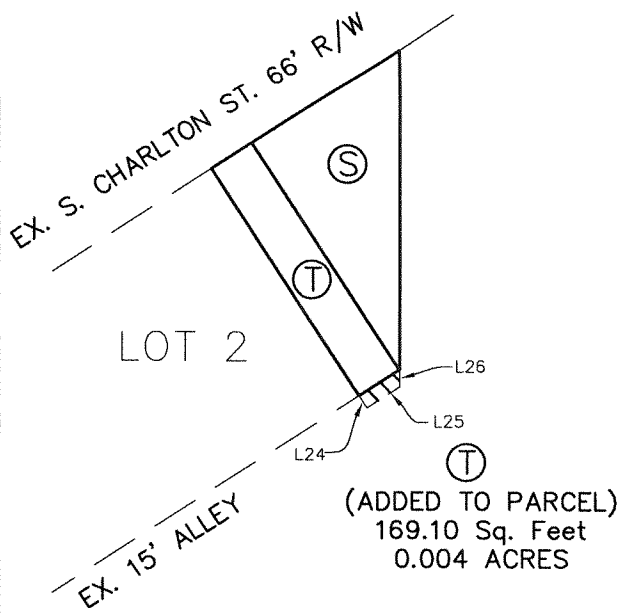

STATE OF KENTUCKY

JOSHUA S.
CALICO
4011

LICENSED
PROFESSIONAL
LAND SURVEYOR

LAND SURVEYOR'S CERTIFICATE

I HEREBY CERTIFY THAT THE SURVEY AS DEPICTED HEREON WAS PERFORMED BY PERSONS UNDER MY DIRECT SUPERVISION, AND MEETS OR EXCEEDS THE MINIMUM TECHNICAL STANDARDS FOR AN URBAN SURVEY AS ESTABLISHED BY THE COMMONWEALTH OF KENTUCKY, PER 201 KAR 18:150 AND IN EFFECT ON THE DATE 05/10/16 THAT THIS SURVEY WAS COMPLETED IN THE FIELD.

Joshua S. Calico 3/6/18
JOSHUA S. CALICO PLS# 4011 DATE:
NOT VALID WITHOUT ORIGINAL SIGNATURE AND SEAL OF THE PROFESSIONAL SURVEYOR

MINDEL, SCOTT & ASSOCIATES, INC.

PLANNING • ENGINEERING • SURVEYING LANDSCAPE
ARCHITECTURE 5151 Jefferson Boulevard Louisville,
Kentucky 40219 (502) 485-1508

APPROVED:
**LOUISVILLE METRO PLANNING
COMMISSION**

DATE May 24, 2018
BY Joel Dock
-cc

ALLEY CLOSURE PLAT

OWNERS:

RWSS PROPERTIES, LLC
(PLAT LOTS-1,2 & 4)
D.B. 11001, PG.'S 287 & 298
115 CHARLTON ST., 113 S CHARLTON ST.
& 1829 R PAYNE ST.
LOUISVILLE, KENTUCKY 40206
TAX BLOCK 070A, LOTS 38,42 & 52

OWNERS:

DOUGHERTY, REALTY GROUP LLC
(PLAT LOTS-3&5)
D.B. 8591, PG. 472
1801 PAYNE ST. & PAYNE ST.
LOUISVILLE, KENTUCKY 40206
TAX BLOCK 070A, LOTS 22 & 21-SUBLOT 22

FORM DIST: TRADITIONAL NEIGHBORHOOD
ZONED: M2, OR3, R5A & R7

DATE: 3-5-18

SCALE: 1"=150'

ADJOINING OWNERS

- (A) LOWES INVESTMENT PROPERTIES, LLC
1701 PAYNE ST.
D.B. 10102, PG. 167
1674.2 SQ. FT.(ADDED TO LOT)
- (B) LOWES INVESTMENT PROPERTIES, LLC
1705 PAYNE ST.
D.B. 10102, PG. 167
400.0 SQ. FT. (ADDED TO LOT)
- (C) DAVID L. BOONE
1709 PAYNE ST.
D.B. 8965, PG. 591
350.0 SQ. FT. (ADDED TO LOT)
- (D) JAMES RONALD DEES
1711 PAYNE ST.
D.B. 10397, PG. 355
250.0 SQ. FT. (ADDED TO LOT)
- (E) KATHERINE A. GARBARINO & WILLIAM F. OWENS
1713 PAYNE ST.
D.B. 10454, PG. 628
250.0 SQ. FT. (ADDED TO LOT)
- (F) SCOTT L. MASSEY
1715 PAYNE ST.
D.B. 8436, PG. 510
250.0 SQ. FT. (ADDED TO LOT)
- (G) TRACY L. BUGG
1717 PAYNE ST.
D.B. 8272, PG. 711
250.0 SQ. FT. (ADDED TO LOT)
- (H) JENA C. WALKER
1719 PAYNE ST.
D.B. 10172, PG. 591
300.0 SQ. FT. (ADDED TO LOT)
- (I) GREGORY FIELDS
1721 PAYNE ST.
D.B. 9795, PG. 018
300.0 SQ. FT. (ADDED TO LOT)
- (J) DEBBIE BERRY & PAIGE E. SHANK
1723 PAYNE ST.
D.B. 8569, PG. 064
350.0 SQ. FT. (ADDED TO LOT)
- (K) KAREN H. & SARA DANIELLE REED
1729 PAYNE ST.
D.B. 10279, PG. 015
400.0 SQ. FT. (ADDED TO LOT)
- (L) JUSTIN R. & ELIZABETH W. WOOD
1731 PAYNE ST.
D.B. 8984, PG. 327
400.0 SQ. FT. (ADDED TO LOT)
- (M) GARY W. & CAROLYN MURPHY
1733 PAYNE ST.
D.B. 8668, PG. 075
500.0 SQ. FT. (ADDED TO LOT)
- (N) DOUGHERTY REALTY GROUP, LLC
1737 PAYNE ST.
D.B. 8687, PG. 440
300.0 SQ. FT. (ADDED TO LOT)
- (O) DOUGHERTY REALTY GROUP, LLC
1741 PAYNE ST.
D.B. 8591, PG. 477
500.0 SQ. FT. (ADDED TO LOT)
- (P) TAYLOR PROPERTIES, INC.
1829 PAYNE ST.
D.B. 4317, PG. 262
829.8 SQ. FT. (ADDED TO LOT)
- (Q) D.D. WILLIAMSON, INC.
1901 R PAYNE ST.
D.B. 4317, PG. 262
(NO SQ. FT. ADDED TO THIS LOT)
- (R) LOUISVILLE & NASHVILLE RAILROAD
NO DEED LISTED
13,674.6 SQ. FT
(ADDED TO LOT)
- (S) RONALD LEE COX
109 S CHARLTON ST.
D.B. 8226, PG. 902
2,339.7 SQ. FT. (ADDED TO LOT)
- (T) RONALD LEE COX
111 S CHARLTON ST.
D.B. 8226, PG. 913
187.5 SQ. FT. (ADDED TO LOT)

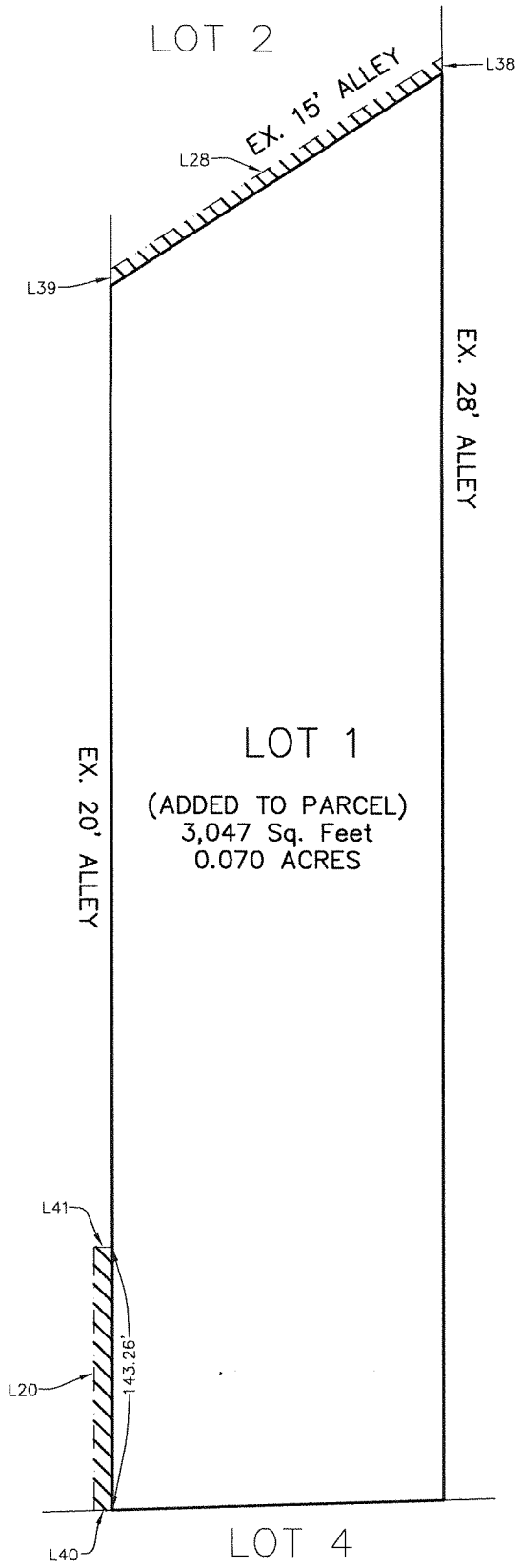

APPROVED:
LOUISVILLE METRO PLANNING
COMMISSION

DATE May 24, 2018
BY Joel Dock -cc

STATE OF KENTUCKY
JOSHUA S. CALICO
4011
LICENSED PROFESSIONAL LAND SURVEYOR

LAND SURVEYOR'S CERTIFICATE

I HEREBY CERTIFY THAT THE SURVEY AS DEPICTED HEREON WAS PERFORMED BY PERSONS UNDER MY DIRECT SUPERVISION, AND MEETS OR EXCEEDS THE MINIMUM TECHNICAL STANDARDS FOR AN URBAN SURVEY AS ESTABLISHED BY THE COMMONWEALTH OF KENTUCKY, PER 201 KAR 18:150 AND IN EFFECT ON THE DATE 05/10/16 THAT THIS SURVEY WAS COMPLETED IN THE FIELD.

Joshua S. Calico 3/6/18
JOSHUA S. CALICO PLS# 4011 DATE:

NOT VALID WITHOUT ORIGINAL SIGNATURE AND SEAL OF THE PROFESSIONAL SURVEYOR

MINDEL, SCOTT & ASSOCIATES, INC.
PLANNING • ENGINEERING • SURVEYING LANDSCAPE
ARCHITECTURE 5151 Jefferson Boulevard Louisville,
Kentucky 40219 (502) 485-1508

ALLEY CLOSURE PLAT

OWNERS:
RWSS PROPERTIES, LLC
(PLAT LOTS-1,2 & 4)
D.B. 11001, PG.'S 287 & 298
115 CHARLTON ST., 113 S CHARLTON ST.
& 1829 R PAYNE ST.
LOUISVILLE, KENTUCKY 40206
TAX BLOCK 070A, LOTS 38,42 & 52

OWNERS:
DOUGHERTY, REALTY GROUP LLC
(PLAT LOTS-3&5)
D.B. 8591, PG. 472
1801 PAYNE ST. & PAYNE ST.
LOUISVILLE, KENTUCKY 40206
TAX BLOCK 070A, LOTS 22 & 21-SUBLOT 22

FORM DIST: TRADITIONAL NEIGHBORHOOD
ZONED: M2, OR3, R5A & R7
DATE: 3-5-18 SCALE: 1"=150'