

NORTH AND ALL BEARINGS
 SHOWN HEREON REFER TO GRID
 NORTH, KENTUCKY STATE PLANE
 COORDINATE SYSTEM, NORTH
 ZONE, NAD 1983

NOTES
 1. This Plat is subject to easements and restrictions of record.
 2. Portions of Zib Lane & Paul Road were closed in Docket No. 1-20-06, Ordinance No. 219, Series 2006 and recorded in Deed Book 8952, Page 261.
 3. Paul Road closure containing 26,765 Square Feet or 0.614 Acre. Faulkner Lane, Fred Lane and Zib Lane, containing 225,152 Square Feet or 5.169 Acres.

LOCATION MAP
 NO SCALE

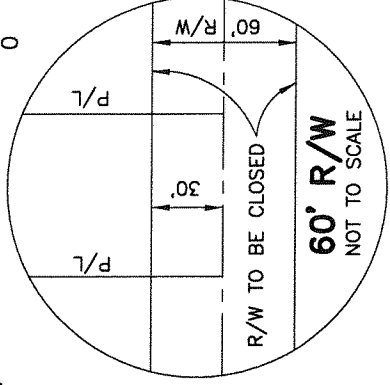
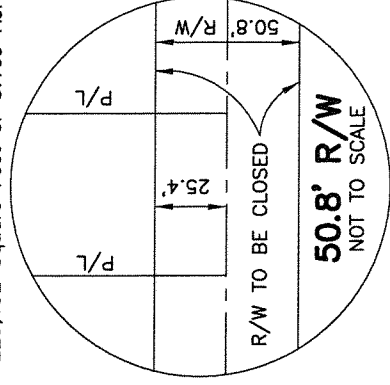
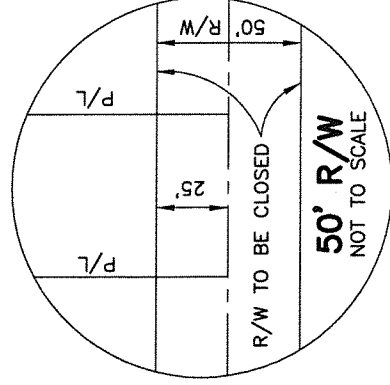
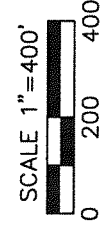

LAND SURVEYOR'S CERTIFICATE

I HEREBY CERTIFY THAT THIS PLAT WAS MADE UNDER MY SUPERVISION AND THAT IT IS CORRECT TO THE BEST OF MY KNOWLEDGE AND BELIEF. THIS IS NOT A BOUNDARY SURVEY AND DOES NOT COMPLY WITH 201 KAR 18.150.

Steven L. Burch #3022 10/07/16
 STEVEN L. BURCH, PLS NO. 3022 Date

SABAK, WILSON & LINGO INC.
 Engineers, Landscape Architects & Planners
 The Henry Clay
 608 S. Third Street
 Louisville, Kentucky 40202
 PH: 502-584-6271 FAX: 502-584-6292

STREET CLOSURE PLAT
ZIB LANE, FRED LANE, FAULKNER
LANE & PAUL ROAD
DOCKET NO. 16STREETS1015

OWNER: Louisville Regional Airport Authority
 P.O. Box 9129
 Louisville Kentucky 40209
 D.B. 6964, P. 156, D.B. 8458, P. 742
 D.B. 10308, P. 540, D.B. 10432, P. 541
 D.B. 10625, P. 390

OWNER: Louisville Renaissance Zone Corporation
 P.O. Box 9129
 Louisville Kentucky 40209
 D.B. 8985, P. 395, D.B. 8986, P. 25
 D.B. 9727, P. 34

ZONING: EZ-1
FORM DISTRICT: SUBURBAN WORKPLACE
DATE: AUGUST 31, 2016 **JOB NO.:** 2504-MP16
REV.: OCTOBER 07, 2016

SCALE: 1"=400'

NORTH AND ALL BEARINGS SHOWN
HEREON REFER TO PLAT AND
SUBDIVISION BOOK 18, PAGE 47



VICINITY MAP
NOT TO SCALE

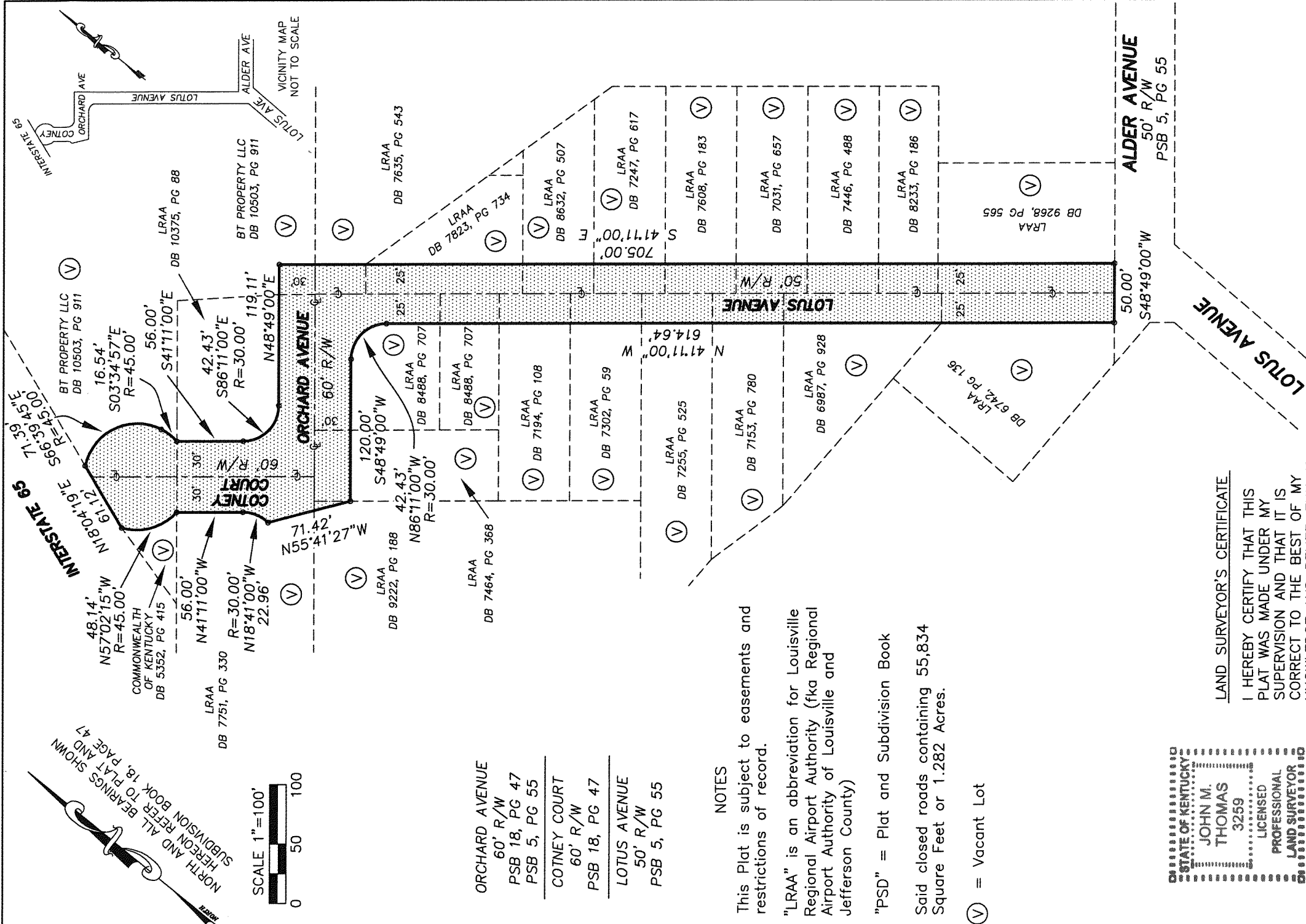

ORCHARD AVENUE
60' R/W
PSB 18, PG 47
PSB 5, PG 55

COTNEY COURT
60' R/W
PSB 18, PG 47

LOTUS AVENUE
50' R/W
PSB 5, PG 55

NOTES

This Plat is subject to easements and restrictions of record.

"LRAA" is an abbreviation for Louisville Regional Airport Authority (fka Regional Airport Authority of Louisville and Jefferson County)

"PSD" = Plat and Subdivision Book

Said closed roads containing 55,834 Square Feet or 1.282 Acres.

(V) = Vacant Lot

STATE OF KENTUCKY
JOHN M. THOMAS
3259
LICENSED PROFESSIONAL LAND SURVEYOR

LAND SURVEYOR'S CERTIFICATE

I HEREBY CERTIFY THAT THIS PLAT WAS MADE UNDER MY SUPERVISION AND THAT IT IS CORRECT TO THE BEST OF MY KNOWLEDGE AND BELIEF. THIS IS NOT A BOUNDARY SURVEY AND DOES NOT COMPLY WITH 201 KAR 18.150.

John M. Thomas
JOHN M. THOMAS, PLS NO. 3259 DATE

SABAK, WILSON & LINGO INC.
Engineers, Landscape Architects & Planners
The Henry Clay
608 S. Third Street
Louisville, Kentucky 40202
PH: 502-584-6271 FAX: 502-584-6292

**STREET CLOSURE PLAT
LOTUS AVENUE, COTNEY COURT
AND ORCHARD AVENUE
DOCKET NO. 16STREETS1015**

APPLICANT:
LOUISVILLE REGIONAL AIRPORT AUTHORITY
P.O. BOX 9129
LOUISVILLE KENTUCKY 40209

ZONING: EZ-1 DATE: OCTOBER 6, 2016 JOB NO.: 2504-MP17
SCALE: 1"=100'