

21- WAIVER-0163 & 22-WAIVER-0003

**Proposed McDonalds
2961 Breckenridge Lane**



Louisville Metro Development Review Committee

Molly Clark, Planner I

February 16, 2022

Request(s)

- Waiver from 5.6.1.C.1 of the Land Development Code to not provide 50% clear windows and doors for façade facing the public Right-of-way (21-WAIVER-0163)
- Waiver from table 10.2.6 of the Land Development Code to provide a 10 FT VUA/LBA instead of the required 15 FT. (22-WAIVER-0003)

Site Context

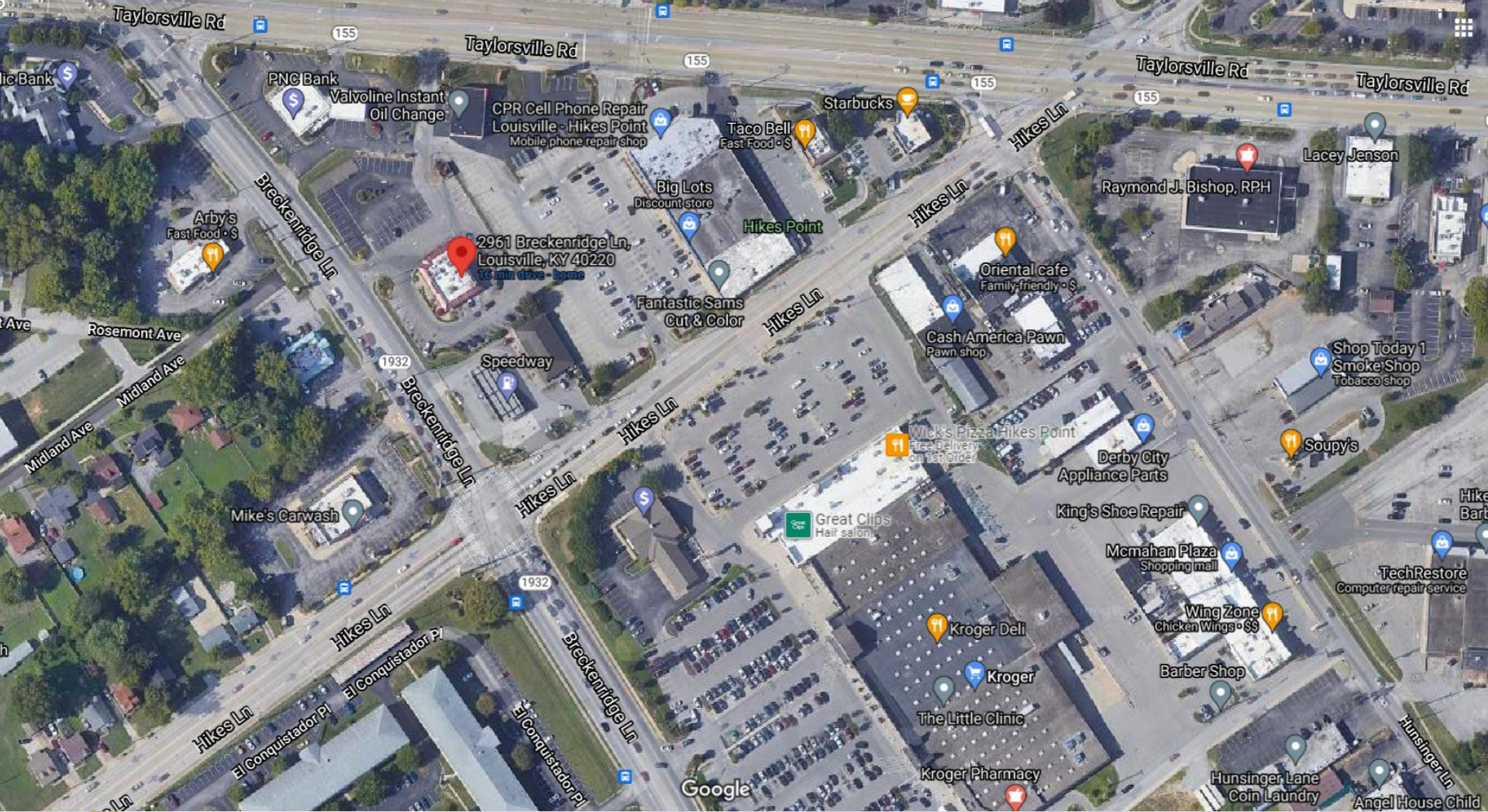

Case Summary

- C-2, Regional Center Form District
- Related to Category 2b under 20-CAT2-0037
- Proposing to demolition existing McDonalds and build a new one
- New building will be 4,365 SF

Zoning/Form Districts

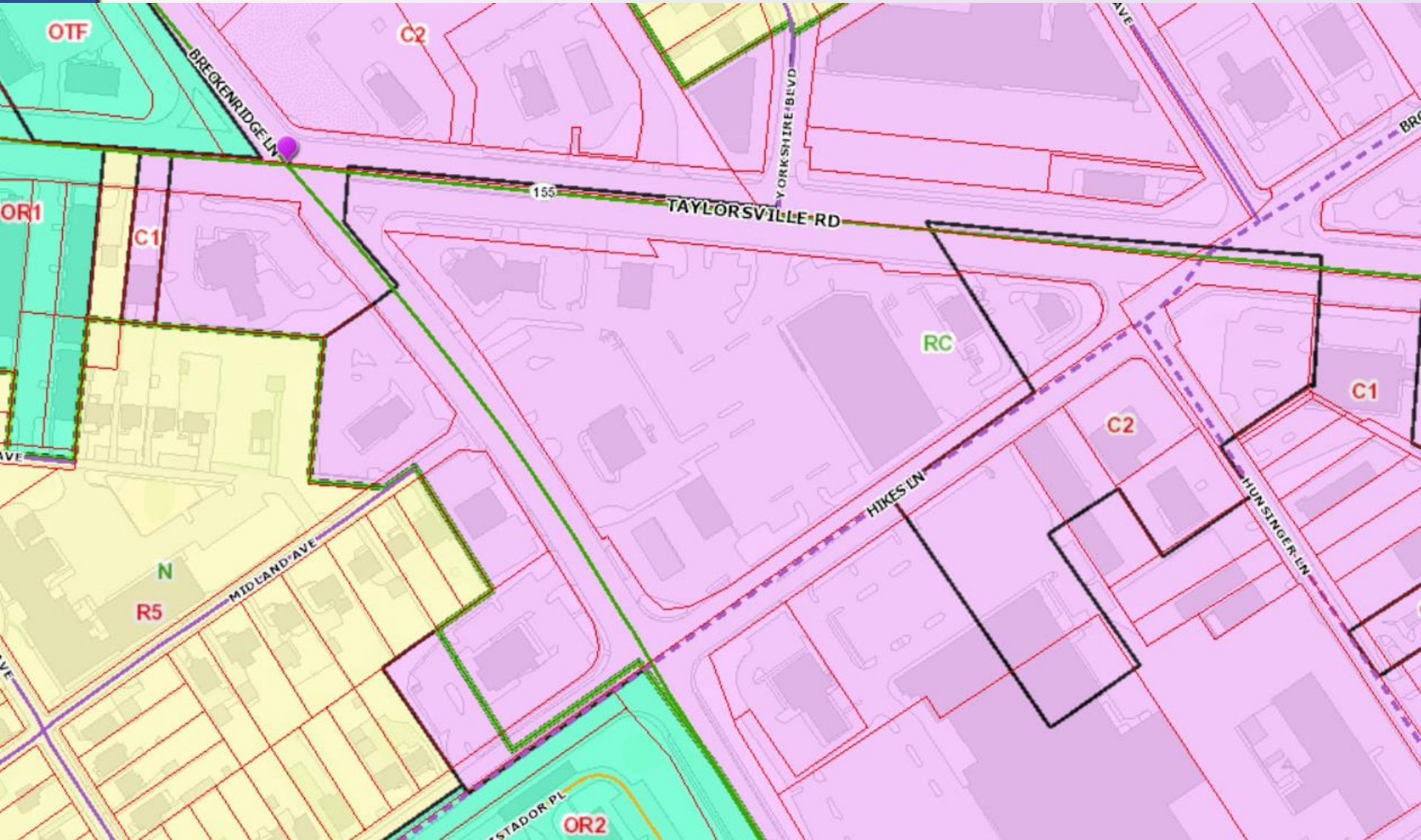

Aerial Photo

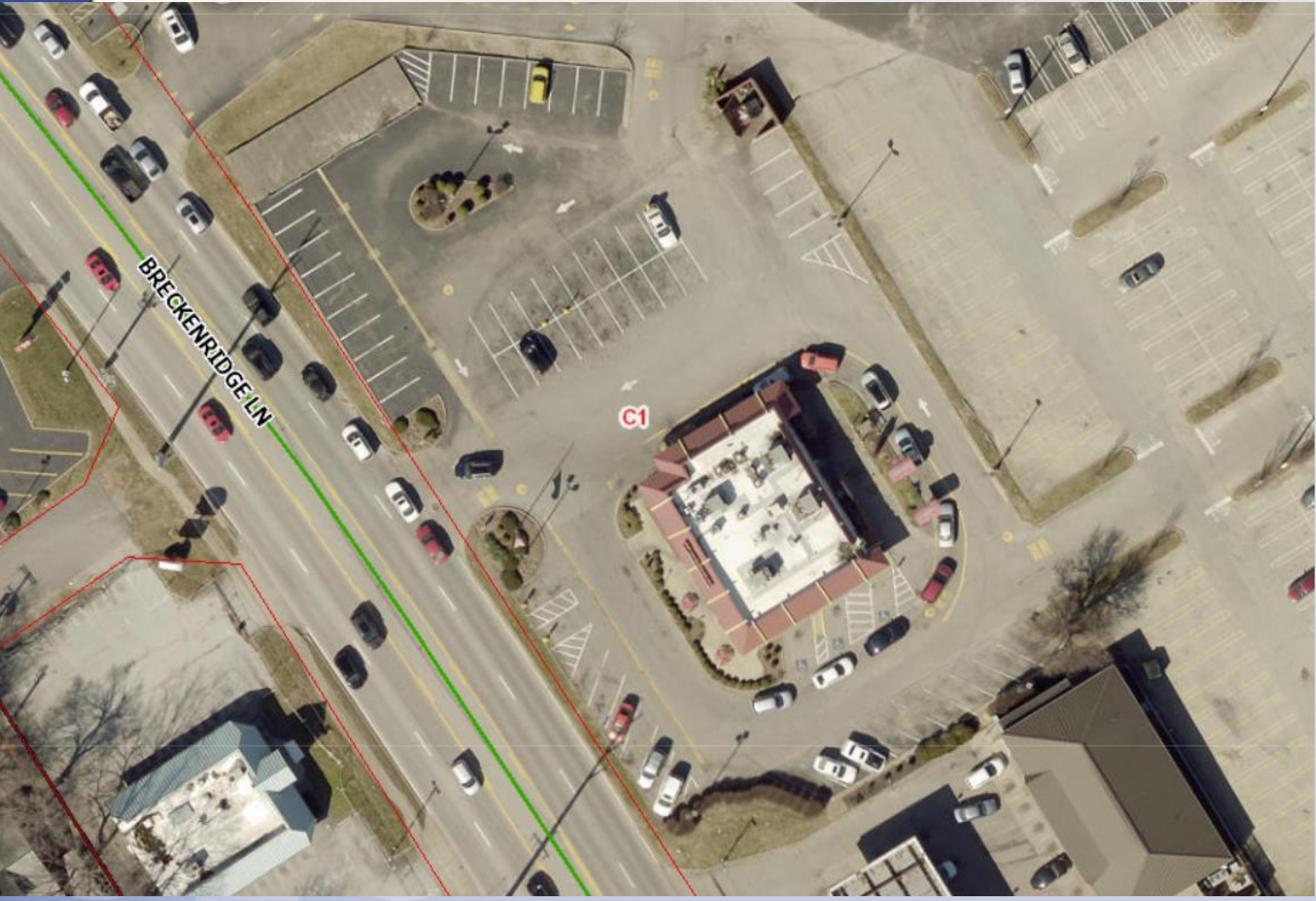

Site Photos-Subject Property



Site Photos-Surrounding Areas



Applicant's Development Plan

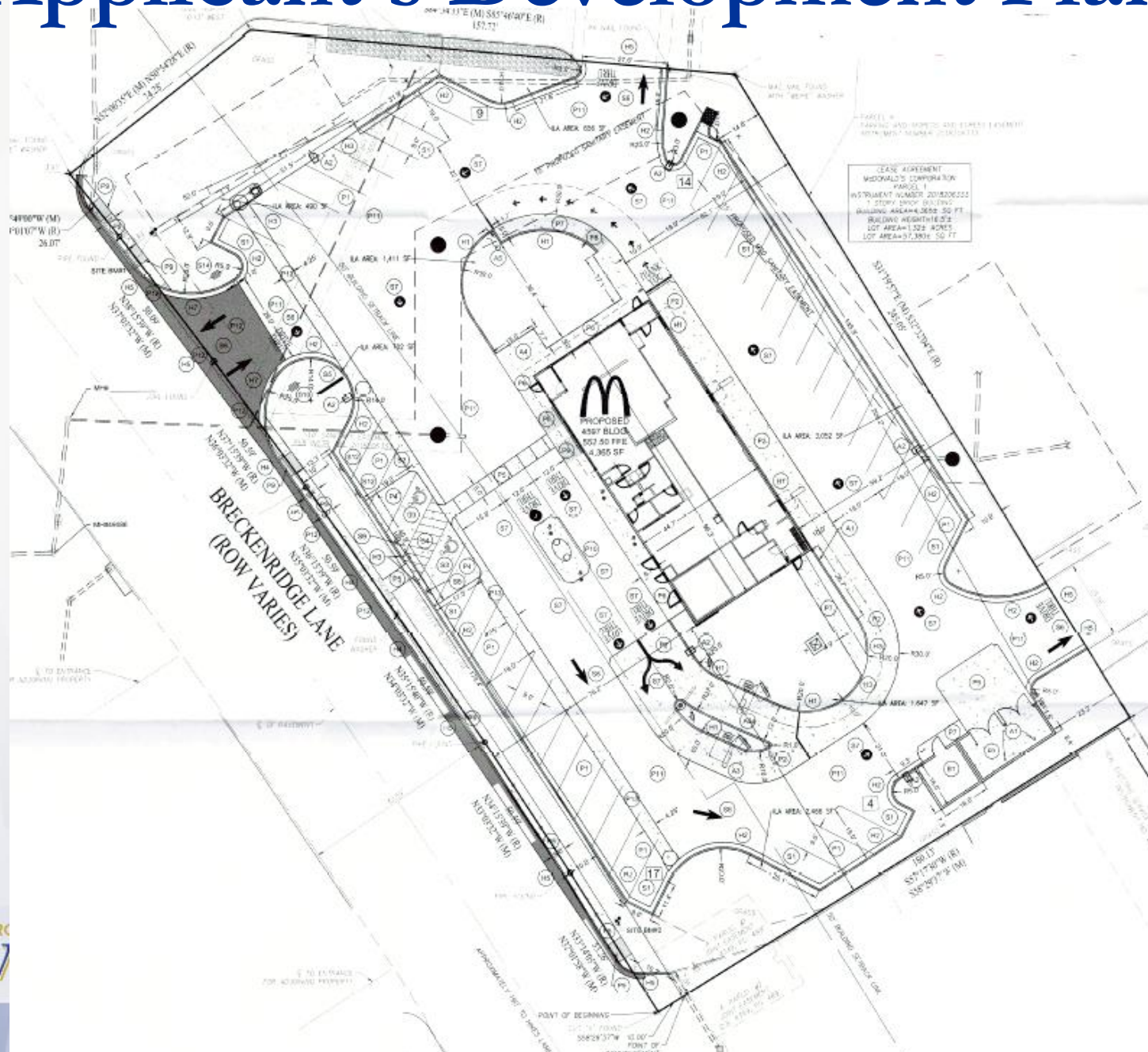

Waivers Requested

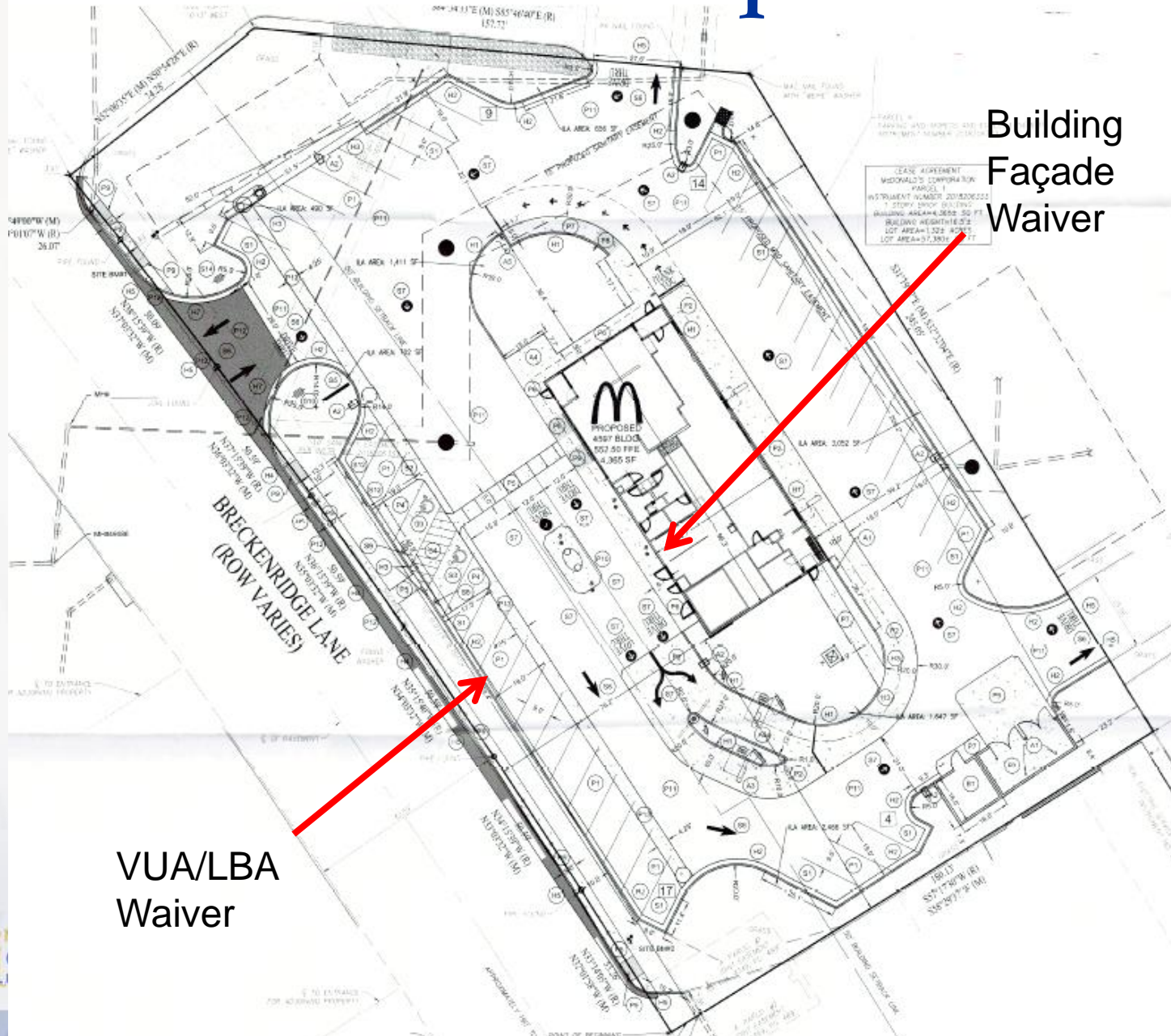

Applicant's Rendering

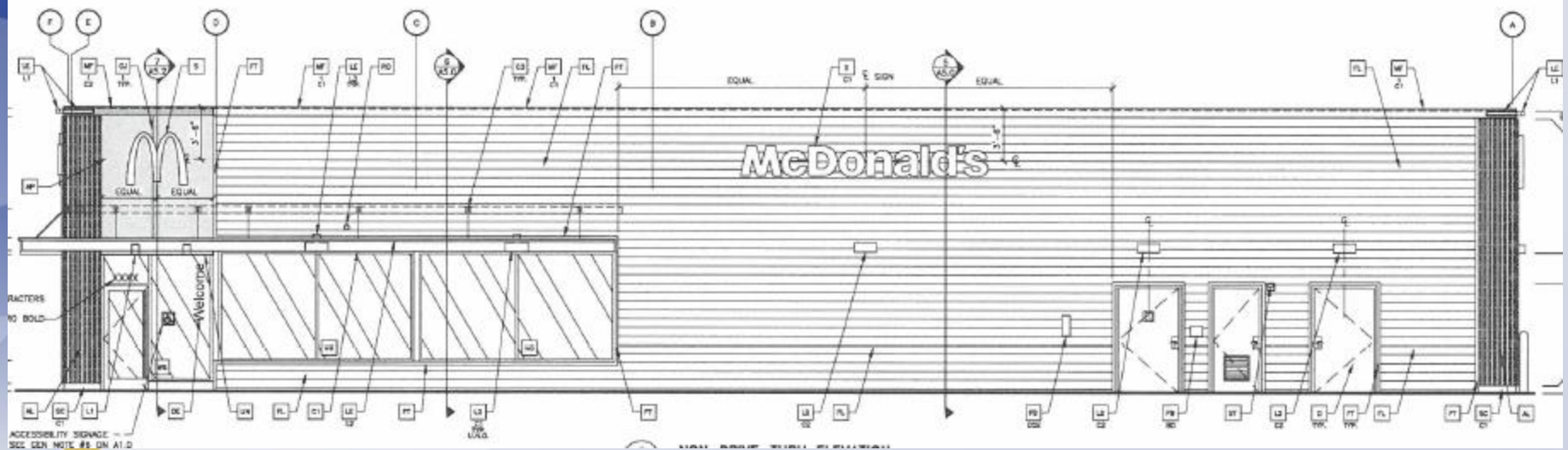
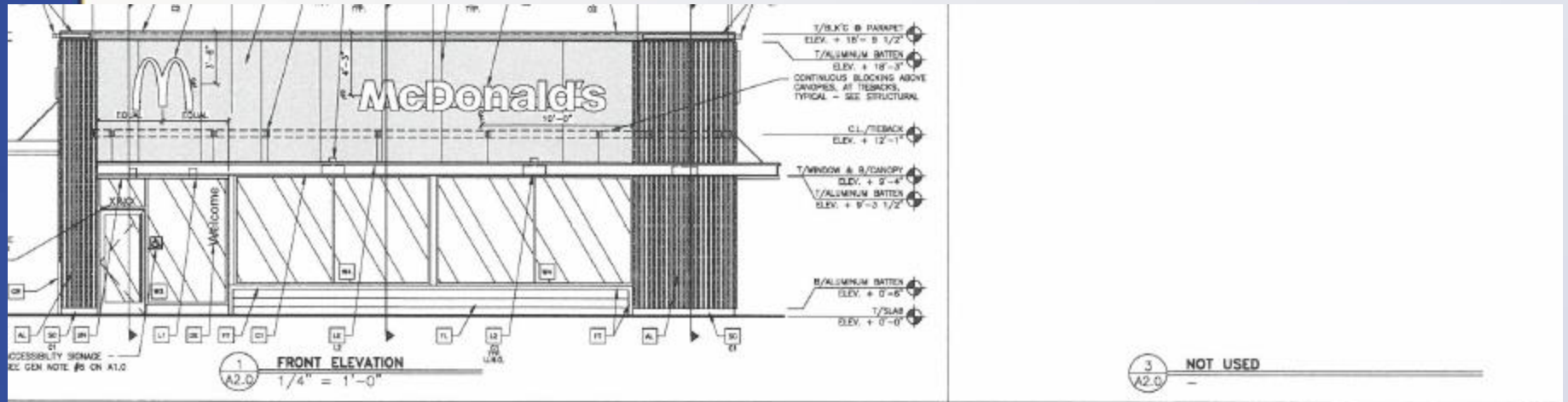

Applicant's Rendering

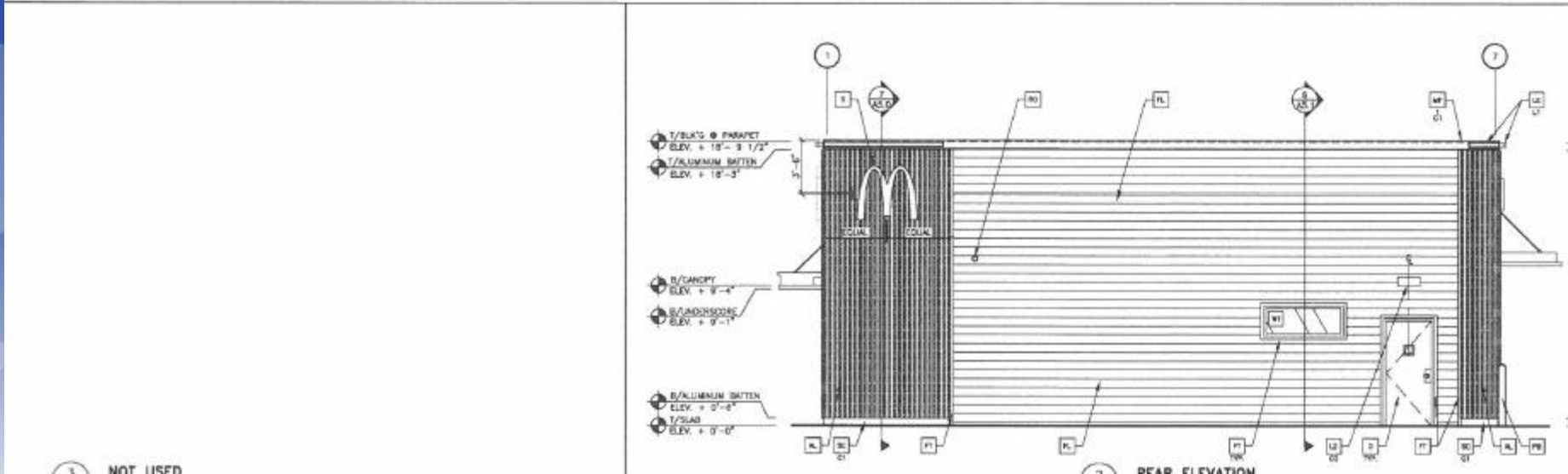
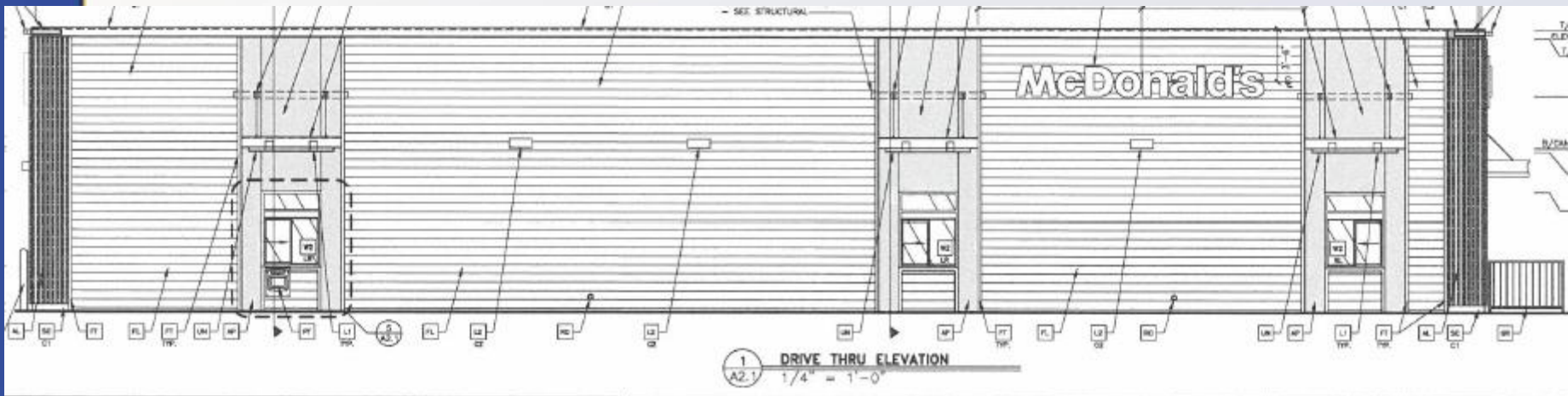

Staff Finding

- The requests are adequately justified and meet the standards of review.

Required Actions

- APPROVE or DENY the WAIVER 5.6.1.C.1 of the Land Development Code to not provide 50% clear windows and doors for façade facing the public Right-of-way. (21-WAIVER-0163)
- APPROVE or DENY the WAIVER table 10.2.6 of the Land Development Code to provide a 10 FT VUA/LBA instead of the required 15 FT. (22-WAIVER-0003)