

Case No. 17AMEND1000

LDC Text Amendment - Form District Lighting LDC Text Amendment



Planning/Zoning, Land Design and Development
Committee

Brian Mabry, AICP, Planning Supervisor

August 1, 2017

Request

Amend LDC Sec. 4.1.3, Lighting, to include additional form districts and height measurement methodology

Background

- LDC establishes the following form districts

Traditional Form Districts	Suburban Form Districts
Traditional Neighborhood	Neighborhood
Traditional Workplace	Suburban Workplace
Traditional Marketplace Corridor	Suburban Marketplace Corridor
Town Center	Regional Center
Village	Village – Outlying
Downtown	Campus

Form Districts in Jefferson County - May 2017

 Traditional Form Districts

 Suburban Form Districts

 Interstate

 Major Arterial

 Minor Arterial

 Ohio River

 Jefferson County Boundary

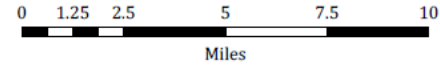
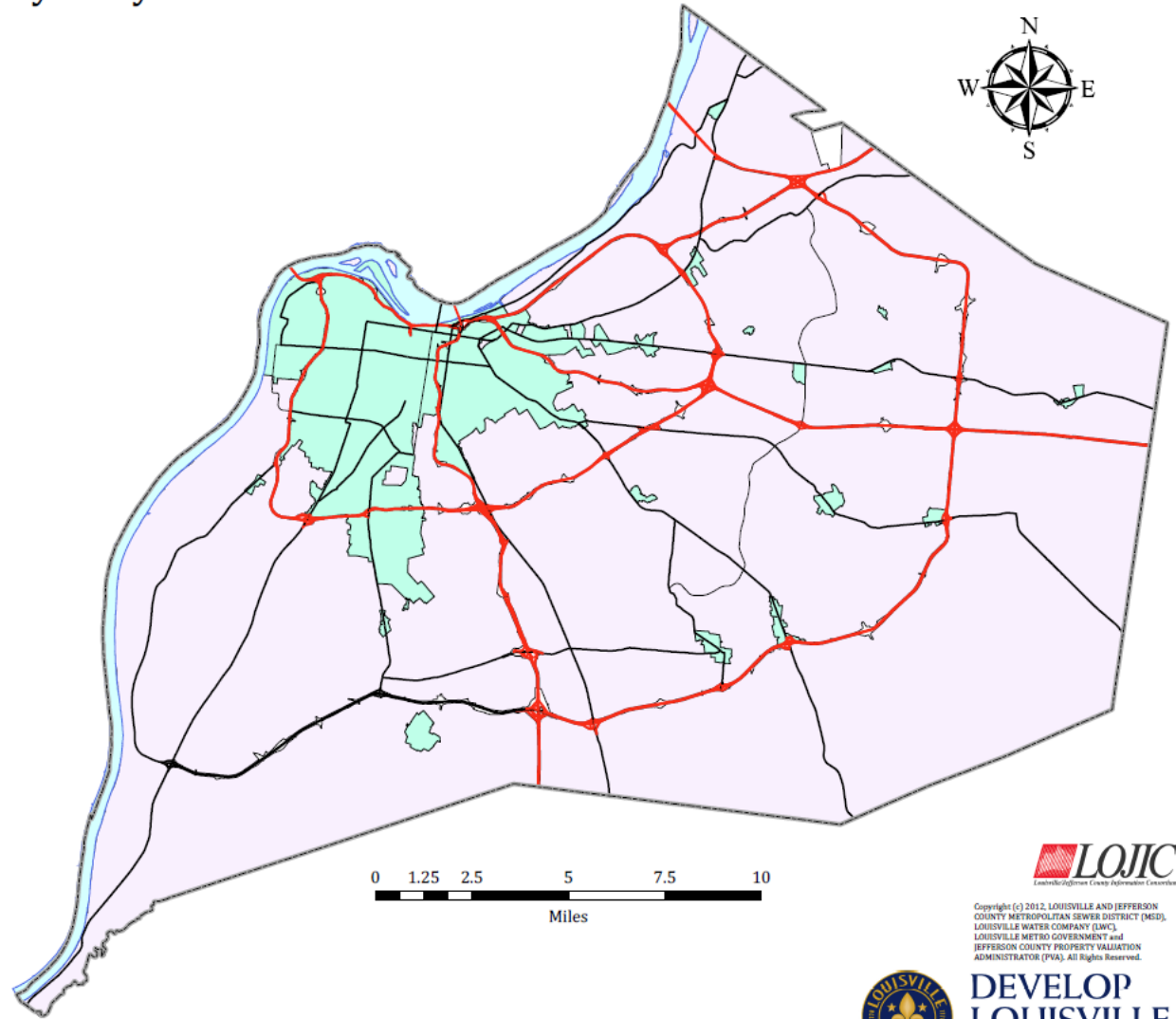













Copyright (c) 2012, LOUISVILLE AND JEFFERSON COUNTY METROPOLITAN SEWER DISTRICT (MSD), LOUISVILLE WATER COMPANY (LWC), LOUISVILLE METRO GOVERNMENT and JEFFERSON COUNTY PROPERTY VALUATION ADMINISTRATOR (PVA). All Rights Reserved.







DEVELOP LOUISVILLE
LOUISVILLE FORWARD

Form Districts in Jefferson County - May 2017

-  TRADITIONAL MARKETPLACE CORRIDOR
-  TRADITIONAL NEIGHBORHOOD
-  TRADITIONAL WORKPLACE
-  TOWN CENTER
-  VILLAGE CENTER
-  DOWNTOWN

-  NEIGHBORHOOD
-  REGIONAL CENTER
-  SUBURBAN MARKETPLACE CORRIDOR
-  SUBURBAN WORKPLACE
-  CAMPUS
-  VILLAGE
-  NO FORM DISTRICT IN EFFECT

-  Interstate
-  Major Arterial
-  Minor Arterial
-  Ohio River
-  Jefferson County Boundary

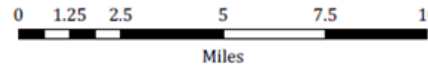
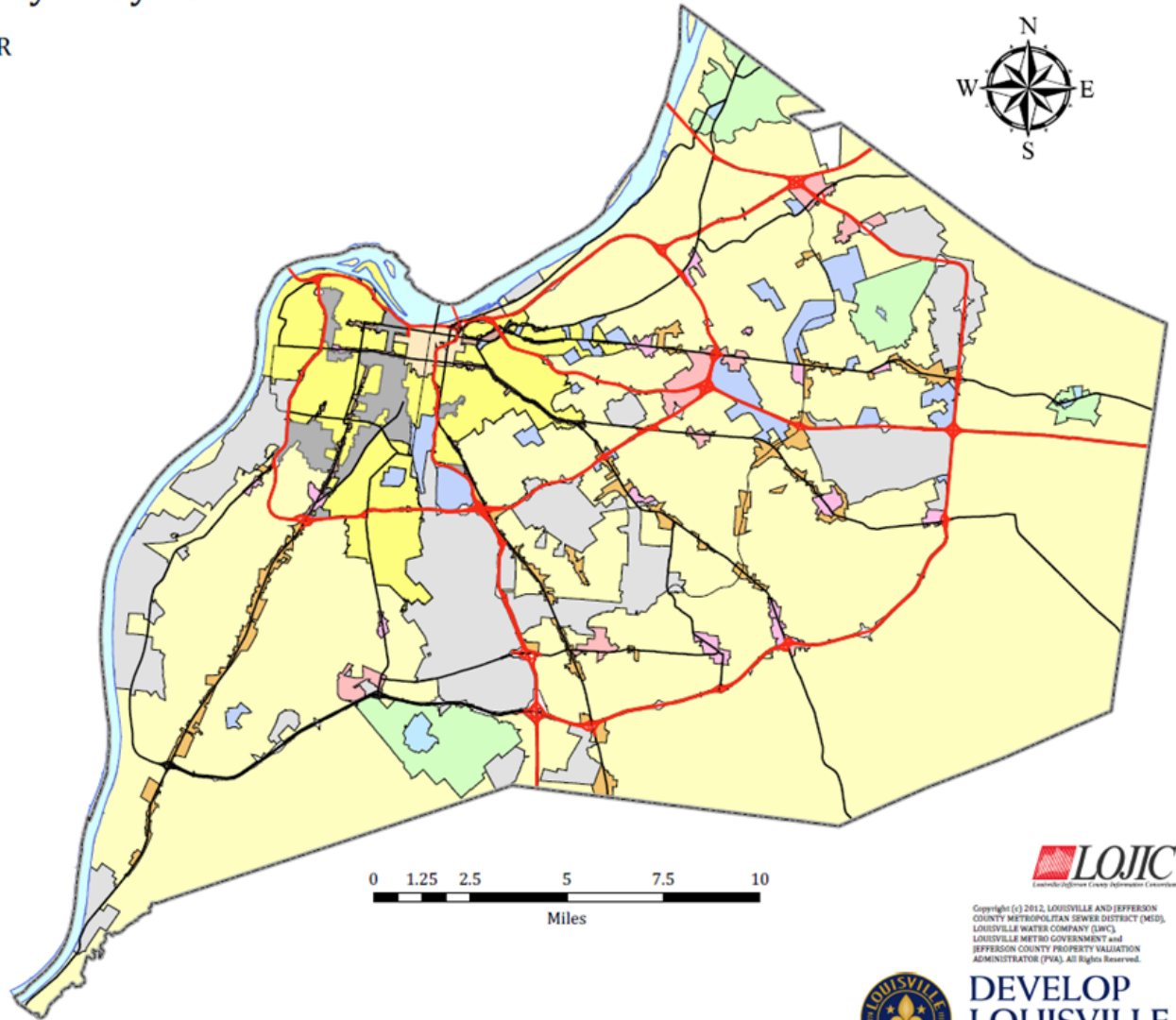

Copyright (c) 2012, LOUISVILLE AND JEFFERSON COUNTY METROPOLITAN SEWER DISTRICT (MSD), LOUISVILLE WATER COMPANY (LWC), LOUISVILLE METRO GOVERNMENT and JEFFERSON COUNTY PROPERTY VALUATION ADMINISTRATOR (PVA). All Rights Reserved.



DEVELOP LOUISVILLE
LOUISVILLE FORWARD

Background

b. The following items shall apply to the mounting height of luminaires:

- i. Within the Neighborhood or Village form district or within a form district transition zone related to a Neighborhood or Village form district, any luminaire with a lamp or lamps rated at a total of more than 1800 lumens, and all flood or spot luminaires with a lamp or lamps rated at a total of more than 900 lumens shall be mounted at a height equal to or less than thirty (30) feet unless otherwise approved by the Planning Commission.
- ii. Within the Traditional Neighborhood, Traditional Workplace, or Traditional Marketplace Corridor form district or within a form district transition zone related to the Traditional Neighborhood, Traditional Workplace or Traditional Marketplace Corridor form district, any luminaire with a lamp or lamps rated at a total of more than 1800 lumens, and all flood or spot luminaires with a lamp or lamps rated at a total of more than 900 lumens shall be mounted at a height equal to or less than twenty (20) feet unless otherwise approved by the Planning Commission.
- iii. Luminaires mounted on residential structures shall be exempt from items (i.) and (ii.) above.

Background

- Purpose of 4.1.3.B.2.b is to set standards for outdoor lighting outside of the public right-of-way in various form districts.
- LDC has 12 form districts, seven of which are not listed in the quoted text on previous slide
 - Town Center
 - Regional Center
 - Downtown
 - Village - Outlying
 - Suburban Workplace
 - Campus
 - Suburban Marketplace Corridor
- In addition, there is no specific way established to measure the height of outdoor lighting.

Background

- On June 9, Planning Committee met to discuss the proposed changes. Agreed with changes proposed by Staff.
- General consensus that the Neighborhood form district should be moved from paragraph i. to paragraph ii. so that the maximum outdoor lighting height for such form district would go from 30 feet to 20 feet.

Amendment Summary

- Maximum outdoor lighting height proposed to be 30 feet for
 - Suburban Workplace
 - Suburban Marketplace Corridor
 - Regional Center
 - Campus
 - Village-Outlying
- Maximum outdoor lighting height proposed to be 20 feet for
 - Neighborhood (including Tyler Town Center)
 - Traditional Neighborhood
 - Traditional Workplace
 - Town Center (including Tyler Town Center)
 - Downtown
 - Traditional Marketplace Corridor.

Amendment Summary

- Height measured as the distance from the finished grade immediately at the base of the support pole to the point of the luminaire that is closest to grade.

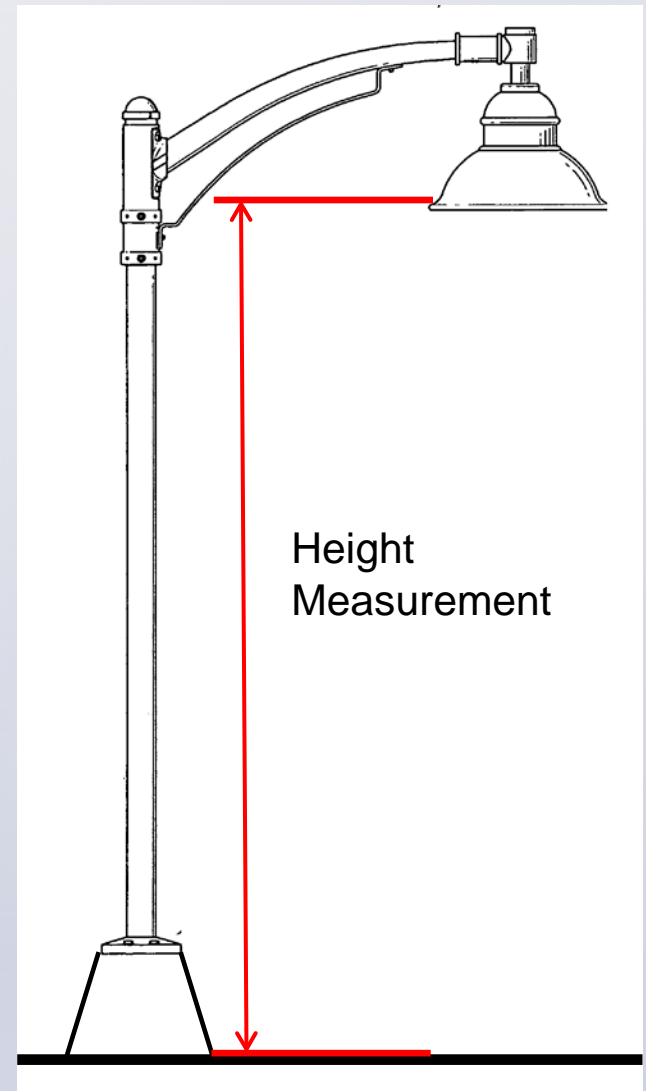

5. Draft LDC Text Amendment Ordinance Related to LDC Section 4.1.3

Section 4.1.3.B.2.b of the Land Development Code is proposed to be amended as follows:

- b. The following items shall apply to the mounting height of luminaires:
 - i. Within the ~~Neighborhood, Suburban Workplace, Suburban Marketplace Corridor, Regional Center, Campus, Village-Outlying,~~ or Village form district or within a form district transition zone related to ~~a Neighborhood or Village~~ such form districts, any luminaire with a lamp or lamps ~~rated at a total of that emit~~ more than 1800 lumens, and all flood or spot luminaires with a lamp or lamps rated at a total of more than 900 lumens shall be mounted at a height equal to or less than thirty (30) feet unless otherwise approved by the Planning Commission.
 - ii. Within the Neighborhood, Traditional Neighborhood, Traditional Workplace, Town Center, Downtown, or Traditional Marketplace Corridor form district or within a form district transition zone related to ~~the Traditional Neighborhood, Traditional Workplace or Traditional Marketplace Corridor~~ such form districts, any luminaire with a lamp or lamps ~~rated at a total of that emit~~ more than 1800 lumens, and all flood or spot luminaires with a lamp or lamps rated at a total of more than 900 lumens shall be mounted at a height equal to or less than twenty (20) feet unless otherwise approved by the Planning Commission.
 - iii. Luminaires mounted on residential structures shall be exempt from items (i.) and (ii.) above.

Section 4.1.3.B. of the Land Development Code is proposed to be amended as follows:

12. Height Measurement

The mounting height of a luminaire subject to the requirements in this Section shall be measured as the distance from the finished grade immediately at the base of the support pole to the point of the luminaire that is closest to grade.

Applicable Plans and Policies

- These proposed amendments to the LDC text are consistent with the following policies & objectives of Cornerstone 2020
 - Marketplace Strategy, Goal A1, Objective A1.2: Clear, consistent, and reasonable standards
 - Marketplace Strategy, Goal C1, Objective C1.1: Improve efficiency and effectiveness of the development review
 - Regional Marketplace Center Form District Objective E4.3, Traditional and Suburban Marketplace Corridor Form Districts Objective F4.4, Traditional and Suburban Workplace Form Districts Objective G4.3, Campus Form District Objective H4.3: Buffers and Compatibility
 - Community Form/Land Use, Compatibility, Policy 8: Lighting

Planning Commission Recommendation

- The Planning Commission conducted a public hearing on 6/29/2017
- The Commission made sufficient findings that the proposal complies with the Comprehensive Plan-Cornerstone 2020
- The Commission recommended approval of the text amendment as presented today to the Planning/Zoning, Land Design and Development Committee (6 members voted)