

**15VARIANCE1041 /
15DEVPLAN1083**

Omni Louisville Hotel & Residences



Louisville Metro Board of Zoning Adjustments

Public Hearing

Brian Davis, AICP, Planning Supervisor

August 3, 2015

Request(s)

Variiances:

1. Variance from 5.2.1, C.5, 6 and 7 to increase the maximum building setback of 0 feet to approximately 23.5 feet at the furthest point along the West Liberty Street property line.
2. Variance from 5.2.1, C.5, 6 and 7 to increase the maximum building setback of 0 feet to approximately 68 feet at the furthest point along the South Second Street property line.
3. Variance from 5.2.1, C.5, 6 and 7 to increase the maximum building setback of 0 feet to approximately 5.9 feet at the furthest point along the South Third Street property line.

Waiver:

1. Waiver from Section 5.2.1, D to accommodate having an innovative high-rise design that proposes two towers that are not stepped back at and above the 14th floor level.

Request(s)

Category 3 Plan:

- 1,136,201 square foot structure
- 600 rooms plus ancillary uses
- 225 residential units
- 22,316 square feet of market and retail space
- Attached parking garage

DDRO Review

On July 29, 2015 the Downtown Development Review Overlay Committee took action on two items related to this request.

15DDRO1011 - A motion to approve the relocation/removal of the old Louisville Water Company building from the site was approved by a vote of 6-2.

15DDRO1012 - A motion to approve the design of the proposed Omni Louisville Hotel and Residences was approved by a vote of 6-2.

DDRO Review

Conditions of Approval:

1. Due to the scale and magnitude of the proposed project, public art should be incorporated into the development.
2. All proposed signage shall be submitted to staff for review and approval prior to installation.
3. On the West Elevation (3rd Street) that was presented to the Committee on July 15, 2015 and currently proposed, Staff recommends that the applicant install 6 additional metal wall screens to be located in front of the garage's exposed concrete wall and located between the proposed wall trellises. The recommendation will minimalize the exposed view of concrete and will hide the ramp of the garage. This will address Principle 5-Parking, Vehicular Use and Access; Guideline P1. b) which states "minimize the use of ramped floors visible from the street".

DDRO Review

Conditions of Approval (cont.):

4. Garage doors with glass window panels should be utilized to secure the parking garage and to further provide a storefront appearance and animated activity along 3rd Street.
5. Report archaeological discoveries such as cistern, artifacts, and other archaeological deposits to the staff immediately for proper documentation.
6. The precast exterior façade material of the towers shall be submitted to Staff for review and approval.
7. Sidewalk amenities including public art, benches, and bike racks shall be submitted to staff for review and approval.
8. The South Lot area of the site shall be landscaped as green space six months after the completion of the project.

Zoning/Form Districts

Subject Property:

- Existing: C-3/Downtown

Adjacent Properties:

- North: C-3/Downtown
- South: C-3/Downtown
- East: C-2/Downtown
- West: C-3/Downtown

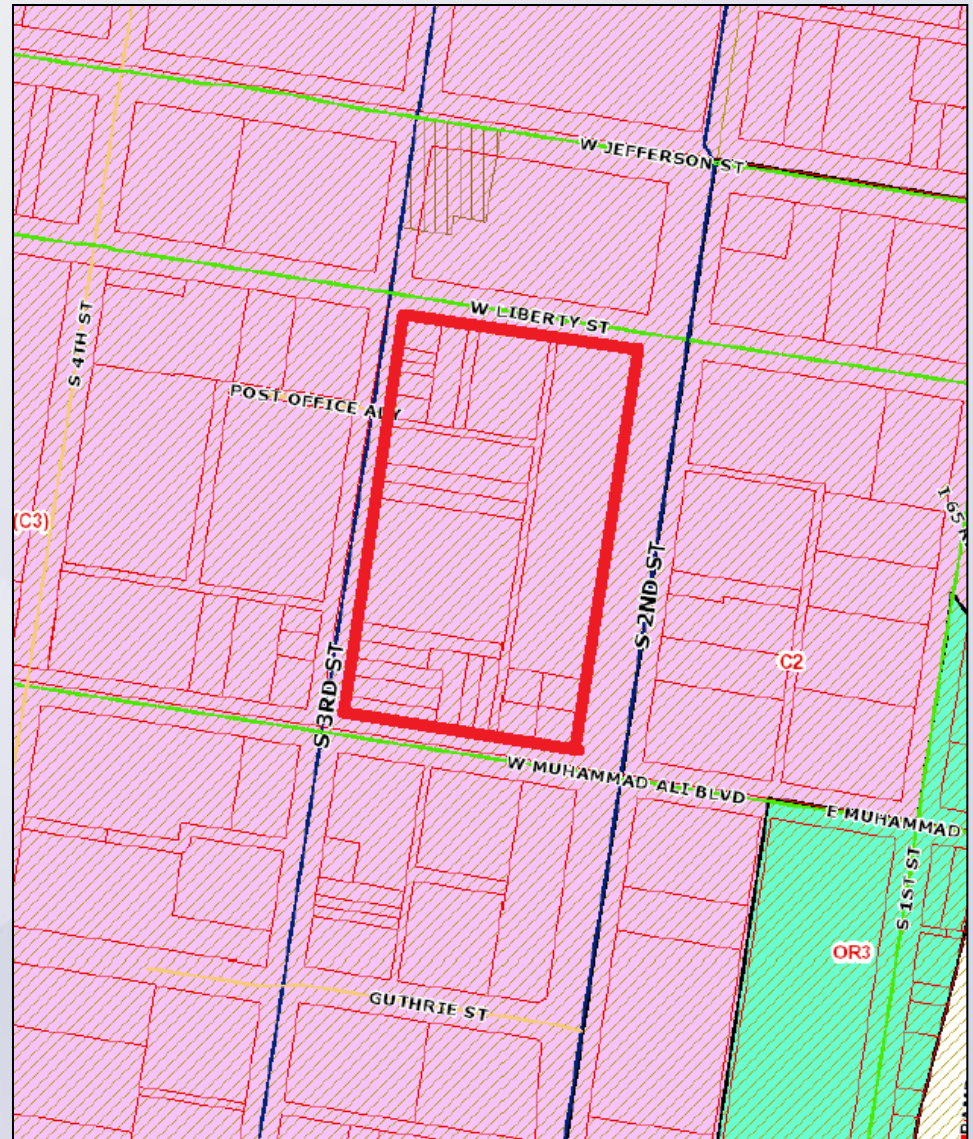

Aerial Photo/Land Use

Subject Property:

- Existing: Parking/Vacant Building

Adjacent Properties:

- North: Hotel
- South: Commercial/Office
- East: Commercial/Office
- West: Commercial/Office



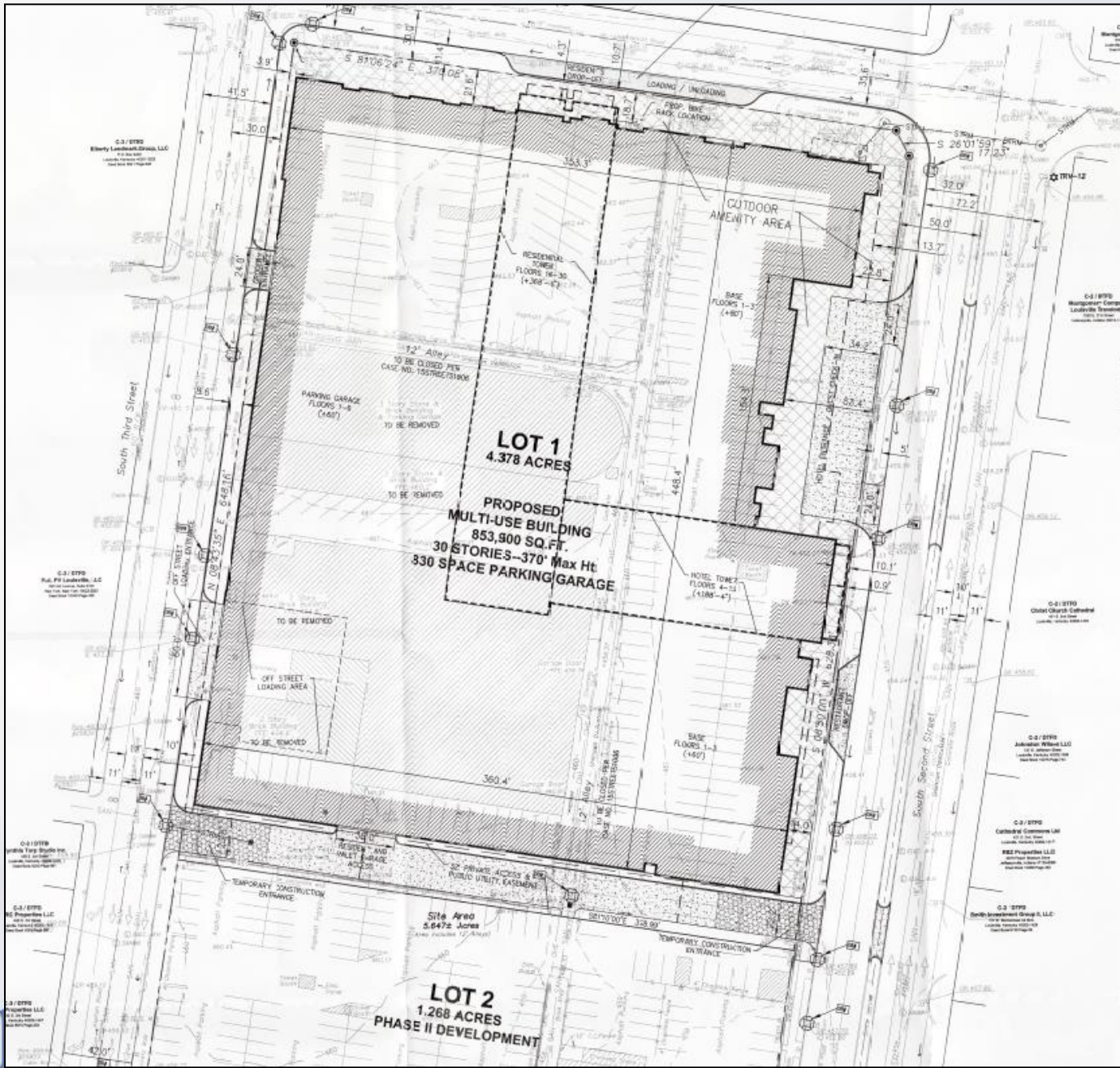



HKS HOSPITALITY GROUP | 00661009/15 | 15 JULY 2015 | HKS #0047200

LOUISVILLE



HKS HOSPITALITY GROUP | ONE LOUISVILLE | 15 JULY 2015 | HQ: #882.882

Louisville

Variiances

Section 5.2.1, C of the LDC:

5. Multiple Structure Lots and New Block Face Developments - A street wall shall be maintained along the entire lot frontage through the placement of one or more structures. Where new development extends along the entire block face between two primary streets, except in Special Districts, the new street wall may be established at a setback from the right-of-way line not to exceed 10 feet or a maximum sidewalk width of 20 feet, whichever is less, provided (a) the street wall setback is uniformly maintained along the entire block frontage through the placement of one or more structures and (b) the sidewalk extends to the street wall.

6. Except as provided above for new block face developments, all corner lots within the Downtown Form District shall maintain a zero foot setback from the street wall for at least 50 feet from the intersection along each street, or the width of the lot, whichever is less.

7. Special Districts - A zero-foot building setback shall be maintained for all structures constructed within the Main/Market and Core/Broadway districts.

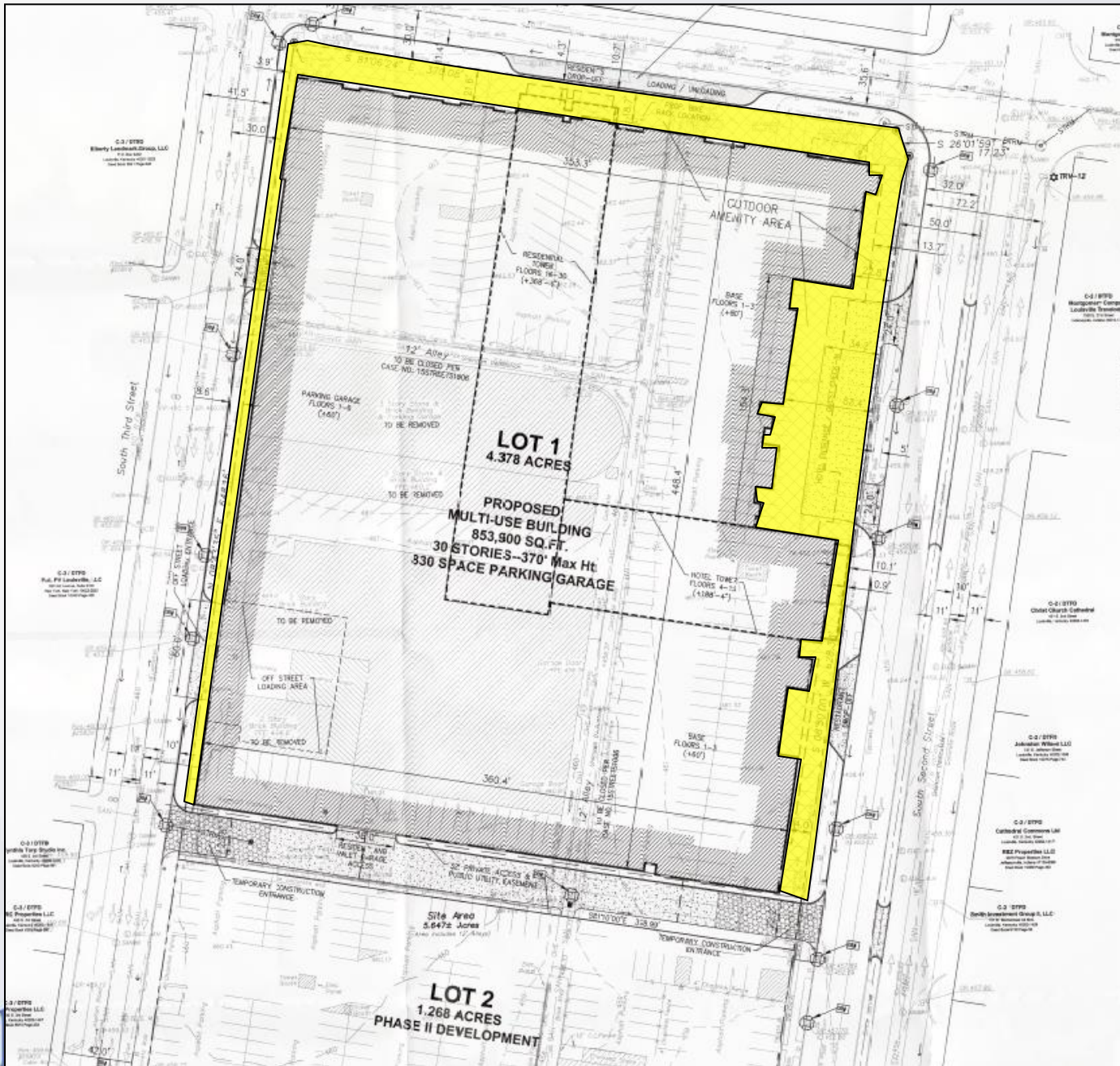

Waiver

D. Building Mass and Form - To allow adequate light and air to reach the street level, structures over 14 stories shall step back from the street wall as follows:

Number of Stories	Minimum Step Back From Street Wall
14 or less	0
15-18	15'
19-22	25'
>22	Additional 10' added after every 4th floor

Waiver

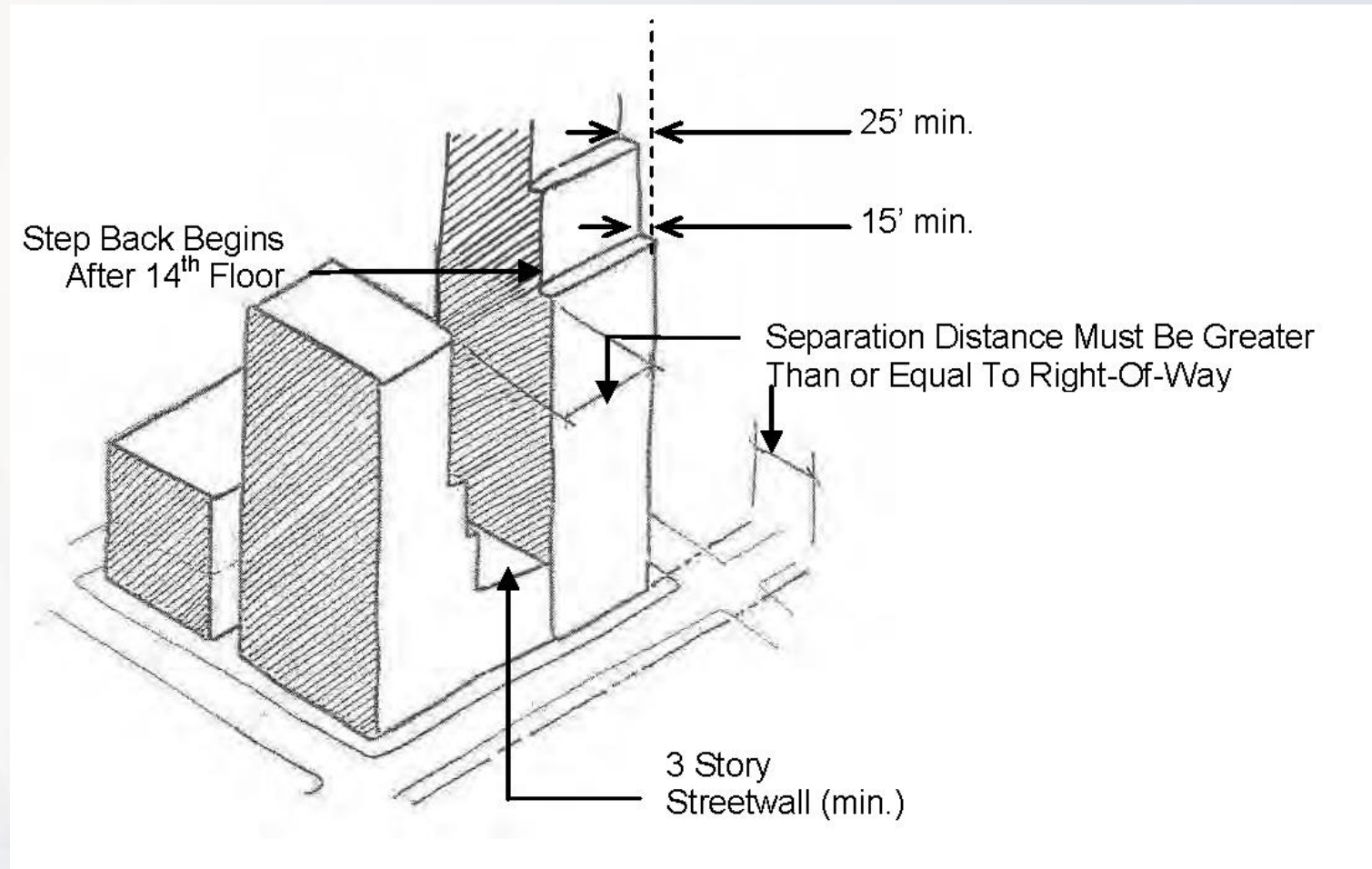



HKS HOSPITALITY GROUP
OMNIDENVER
16 JULY 2015
HKS #0047200

LOUISVILLE

Technical Review

- The applicant is still finalizing the sidewalk/street tree/ROW design along the road frontages.
- Staff recommends adding a condition of approval stating Public Works/Transportation Review can finalize design of the right-of-way at construction phase.

Staff Analysis and Conclusions

- The standards of review have been met for the requested waiver and variances on the site. Based upon the information in the staff report, the testimony and evidence provided at the public hearing, the Board of Zoning Adjustments must determine if the proposal meets the standards for approving the variances, waiver and Category 3 plan.

Required Actions

▪ Variances: Approve/Deny

1. Variance from 5.2.1, C.5, 6 and 7 to increase the maximum building setback of 0 feet to approximately 23.5 feet at the furthest point along the West Liberty Street property line.
2. Variance from 5.2.1, C.5, 6 and 7 to increase the maximum building setback of 0 feet to approximately 68 feet at the furthest point along the South Second Street property line.
3. Variance from 5.2.1, C.5, 6 and 7 to increase the maximum building setback of 0 feet to approximately 5.9 feet at the furthest point along the South Third Street property line.

Required Actions

- **Waivers: Approve/Deny**
 1. Waiver from Section 5.2.1, D to accommodate having an innovative high-rise design that proposes two towers that are not stepped back at and above the 14th floor level.

- **Category 3 Plan: Approve/Deny**