

Louisville Metro Council City Agency Request

- Neighborhood Development Fund (NDF)
- Capital Infrastructure Fund (CIF)
- Municipal Aid Program (MAP)
- Paving Fund (PAV)

Primary Sponsor: Councilman Dan Johnson

Amount: \$1,000 **Date:** January 26, 2016

Description of program/project including public purpose, additional funding sources, location of project/program and any external grantee(s):

\$1,000 transferred to Metro Parks for use towards purchasing the attached ice machine for the Beechmont Community Center.

City Agency: Metro Parks

Contact Person: Jade Barb

Agency Phone: (502) 574-3730

I have reviewed this request for an expenditure of city tax dollars, and have determined the funds will be used for a public purpose.

<u>21</u>		<u>\$1,000</u>	<u>1-26-15</u>
District #	Council Member Signature	Amount	Date

Approved by: _____ _____
Appropriations Committee Chairman Date

Clerk's Office & OMB Use Only:

Request Amount: _____ Amended Amount: _____

Reference #: _____ To OMB: _____

Budget Revision #: _____

Account #: _____

To Project Manager: _____ Completion Date: _____

Actual Cost: _____ Funds Returned: _____

CIF, NDF, MAP OR PAV INTERAGENCY CHECKLIST

Interagency Name: Metro Parks

Program/Project Name: Beechmont Community Center purchase of ice machine

Yes/No/NA

Request Form: Is the Request Signed by all Council Member(s) Appropriating Funding? Yes

Request Form: If matching funds are to be used, are they disclosed with account numbers in the request form description? NA

Request Form: If matching funds are to be used, does the amount of the request exclude the matching fund amount? NA

Request Form: If other funds are to be used for this project, are they disclosed with account numbers in the request form description? NA

Funding Source: If CIF is being requested, does Metro Louisville own/will own the real estate, building or equipment? If not, the funding source is probably NDF. NA

Funding Source: If CIF is being requested, does the project have a useful life of more than one year? If not, the funding source is probably NDF. NA

Ordinance Required: Is the NDF request to a Metro Agency greater than \$5,000? If so, an ordinance is required. No

Ordinance Required: Is the request a transfer from NDF to cost center? If so, is the amount given for the fiscal year \$25,000 or less? No

Supporting Documentation: Does the attachment include a valid estimate and description of cost? Yes

Prepared by:

Bryan Mathews

Date: January 26, 2016





Foodservice Equipment & Smallwares
 3110 Preston Hwy
 Louisville, KY 40213
 502-637-3232
 800-467-6631
 www.dinecompany.com
We Make Foodservice Easier

Quote

01/26/2016

Project:
 Louisville Metro Parks-METR003
 kevin.kinney@louisvilleky.gov
 502-361-5484

From:
 Dine Company
 Sherry Sellers
 3110 Preston Hwy.
 P O Box 34038
 Louisville, KY 40213-1108
 502-637-3232
 (502)637-3232 (Contact)

Item	Qty	Description	Sell	Sell Total
1	1 ea	ICE CUBER WITH BIN  Manitowoc Model No. UY-0140A NEO™ Undercounter Ice Maker, cube-style, air-cooled, self contained, 26"W x 28"D x 38-1/2"H, up to 132-lb. approximately/24hrs, up to 90 lbs ice storage capacity, electronic controls, half dice size cubes, NSF, cETLus, CE, ENERGY STAR®	\$1,850.00	\$1,850.00
	1 ea	3 year parts & labor Commercial warranty		
	1 ea	5 year parts & labor Commercial warranty on evaporator		
	1 ea	5- year parts & 3- year labor Commercial warranty on compressor		
	1 ea	(-161) 115v/60/1ph, 5.5 amps, 6 ft cord with NEMA 5-15P		
2	1 ea	WATER FILTRATION SYSTEM  OptiPure Model No. FXI-11 FX Water Filter System, single 10" sump, (1) CTOS-10 cartridge with IsoNet®, 15,000 gallon capacity, 1.5 gpm, 0.5 micron sediment and chlorine, taste, odor reduction, scale inhibition, for use with ice makers (up to 800 lb. cuber/1,000lb. flaker), coffee makers, steamers and combi ovens, NSF (160-50105)	\$151.00	\$151.00
3	1 ea	DELIVERY DINE COMPANY Model No. DELIVERY AND SET Deliver, uncrate, assemble and set in place all equipment. Includes removal of all related boxes and packing material from sight. CUSTOMER WILL HAVE WATER LINE AND DRAIN IN PLACE.		

Merchandise	\$2,001.00
Installation	\$295.00
Total	\$2,296.00

TERMS AND CONDITIONS – DINE COMPANY – 3110 PRESTON HWY, LOUISVILLE, KY 40213

1. PAYMENT TERMS: Unless otherwise stated in the body of this quote, a down payment of (50%) of the quoted price ("Contract Price") of the equipment and fixtures (collectively, the "Equipment") less applicable state and local taxes is due upon signing this "Terms and Conditions of Sale" (the "Contract"). Equipment will not be ordered prior to signing of agreement and receipt of down payment. Balance of the Contract Price, including applicable state and local sales tax, is due upon delivery of the Equipment. Should Dine Company be unable to deliver or install the Equipment due to the Purchaser's premises not being ready for a period of (30) days after Equipment is ready for delivery, the Purchaser agrees to pay the balance of the Contract Price, including freight charges whether the Equipment was delivered or not. Credit card payments may be accepted for payment, and a 3.25% merchant processing fee will be added to the total purchase price. Purchaser agrees to pay re-delivery charges if the Equipment cannot be delivered on the scheduled trip. Dine Company shall retain title to the Equipment until paid in full, and Purchaser also grants Dine Company a security interest in the Equipment.

2. DELAYS: Delay in Equipment delivery due to, but not limited to, factory error, shipping error (on part of factory or carrier), strikes, and acts of God shall not be the responsibility of Dine Company and in no event shall Dine Company be liable for any damages, including but not limited to special or consequential damages. Delivery delays beyond 30 days from planned date requires Dine Company to store and handle the Equipment. Purchaser will be responsible for a storage and handling fee prorated daily and based on a price not to exceed \$500.00 per month.

3. DAMAGE FREIGHT LIABILITY: Dine Company shall have no liability for damaged Equipment drop shipped from the manufacturer to Purchaser. If any Equipment arrives in damaged condition, Purchaser should not accept it unless the transportation carrier acknowledges the damage on the freight bill. In the event of concealed damage, the Purchaser shall call the delivering carrier for a concealed damage inspection and save the cartilage. Purchaser shall immediately notify Dine Company of any damage. Under no conditions are deductions to be made from the Dine Company's invoice for any damage, loss, breakage or shortage.

4. CANCELLATION AND RESTOCKING: Should Purchaser elect to cancel the order after the signing of the Contract and payment of the initial down payment, the Purchaser agrees to a cancellation charge of up to (15%) of the net value of the subject order to cover Dine Company's invested cost of specifying, engineering, drawing and order processing. Should Purchaser elect to change his order after Dine Company's placement of its order to specified manufacturer(s), then Purchaser agrees to pay Dine Company the proportionate amount of fabrication completed at that time, up to (100%) of the net value of Purchaser's order, plus any freight charges that may occur due to Purchaser's cancellation. All other Equipment and supplies will be subject to a 50% restocking charge plus return freight charges. No returns accepted after 30 days from invoice date.

5. NEW EQUIPMENT-EXCLUSION OF WARRANTIES: All new Equipment is sold with the manufacturer's warranty only. There are no warranties of either merchantability or fitness for a particular purpose use. In any event, Dine Company shall not be responsible for any damages, including but not limited to special, consequential, direct or indirect. The manufacturer or its authorized Representative is solely responsible for warranty work.

6. RECONDITIONED USED EQUIPMENT-WARRANTIES: Unless otherwise provided on the sales invoice or a manufacturer's warranty has been transferred to Purchaser, all reconditioned used equipment is sold with a 30 days parts and labor warranty, excluding travel and overtime.

7. INSTALLATION SERVICE: Installation services are to include receiving, warehousing, delivery to Purchaser's premises, uncrating, and setting-in-place ready for final connection by others. Refrigeration piping, if any, is to be the responsibility of the Purchaser unless specified above. Exhaust system duct work, material and labor, if any, is the responsibility of the Purchaser unless specified above. Purchaser shall also be responsible of the HVAC balancing after the exhaust hood is installed. Plumbing and electrical rough-ins or final connection are not provided by Dine Company and shall be the responsibility of the Purchaser, Contractor or Sub-Contractors (not Dine Company) are responsible for conforming to all prevailing codes: i.e. electrical, plumbing, health etc. and extra charges will be applied if changes are required to include local code requirements. Purchaser is responsible for delivered property and services for insuring and securing against loss due to theft, fire, damage or acts of God.

8. INSTALLATION CHARGES: Labor charges are based on straight time for eight (8) hours, including travel time, in (24) hours day and time and one half for any hours incurred above (8) hours in the same (24) hour day. The Purchaser agrees to reimburse Dine Company for truck expenses, meals and lodging required to transport and install the Equipment unless otherwise specified above.

9. FREIGHT CHARGES: Unless otherwise noted, freight charges are not computed in quoted Equipment prices. These shall be added on and are the responsibility of the Purchaser.

10. TAXES: Unless noted, State and local taxes are not in quoted Equipment prices. These shall be added on and are the responsibility of the Purchaser.

11. FINANCE CHARGES: Unpaid past due balances will be charged 1 1/2% per month.

12. LEGAL FEES: The Purchaser is responsible for attorney's fees, and other fees or costs associated with litigation or other efforts incurred to collect any amount due under this Contract.

13. MODIFICATION OF AGREEMENT: No provision of this Contract may be modified in whole or part except by a written agreement executed by Purchaser and a duly authorized officer of Dine Company.

Pre-payment with order is 50% with subsequent progress payment, with balance due at time of delivery unless otherwise stated in body of the quote.

Accepted and approved by _____

Date _____

Print Name _____



NEO® 140/190 Undercounter Ice Machines

NEO® 140/190 Undercounter Ice Machines

Models

- UR-0140A
- UD-0140W
- UY-0140W
- UD-0190A
- UD-0140A
- UY-0140A
- UR-0190A
- UY-0190A



U-140 / U-190

- Ranging from 140 lbs. (64 kg) to 190 lbs. (79 kg) daily ice production
- Only 26" (66.04 cm) wide, 28.00" (67.31 cm) deep, and 38.50" (82.55 cm) high on 6" (15.24 cm) legs
- Up to 90 lb. (40.8 kg) ice storage capacity

NEO undercounter ice machines are designed to provide ice right where you need it – within reach. Improvements in **Performance, Intelligence and Convenience** make your ice machine easy to own and less expensive to operate.

Performance – NEO produces more ice than ever before while using less water and energy. The storage bin provides industry leading capacity.

Intelligence – NEO provides feedback with full bin and service indicators. Delay function allows you to pause your machine for short periods or days when you're closed.

Convenience – NEO offers a forward-sliding storage bin for easy access to refrigeration components without having to move the entire ice machine. Smooth, sealed food-zone with removable water trough, distribution tube, and damper door for faster cleaning. AlphaSan added to key internal components.

Available **LuminIce® Growth Inhibitor** extends cleaning intervals by reducing yeast and bacteria growth keeping your ice machine cleaner, longer.

Specifications

<p>BTU Per Hour: U-140: 2,150 (average) 2,600 (peak)</p> <p>U-190: 2,150 (average) 2,600 (peak)</p> <p>Compressor: Nominal rating: .42 HP</p> <p>Cupra-Nickel Condenser: (Water-cooled models) Adds protection from corrosive water elements.</p>	<p>Operating Limits:</p> <ul style="list-style-type: none"> • Ambient Temperature Range: 40° to 110°F (4.4° to 43.3°C) • Water Temperature Range: 45° to 90°F (4.4° to 32.2°C) • Water Pressure Ice Maker Water In: Min. 20 psi (137.9 kPa) Max. 80 psi (551.1 kPa) • Condenser Inlet Water In: (Water-cooled only) Min. 20 psi (137.9 kPa) Max. 150 psi (1,034.2 kPa)
--	---



Ice Shape



Half Dice
3/4" x 1 1/4" x 3/4"
(.95 x 2.86 x 2.22 cm)



Dice
1/2" x 1/2" x 1/2"
(2.22 x 2.22 x 2.22 cm)



Regular
1 1/2" x 1 1/4" x 3/4"
(2.86 x 2.86 x 2.22 cm)

Ice Machine Electric

Power Cord:
115/60/1 ice machines are factory pre-wired with a 6' (180 cm) power cord and NEMA 5-15P-plug configuration. 208-230/60/1 ice machines are factory pre-wired with a 6' (180 cm) power cord only, no plug is supplied.

Total Amps:
U-140: 115/60/1: Air-cooled and Water-cooled: 5 amps
208-230/60/1: Air-cooled and Water-cooled: 2.5 amps
U-190: 115/60/1: Air-cooled: 6 amps
208-230/60/1: Air-cooled: 2.5 amps

Maximum fuse size:
Air-cooled and Water-cooled: 15 amps
HACR-type circuit breakers can be used in place of fuses.



COMPANY WITH QUALITY SYSTEM CERTIFIED BY DNV = ISO 9001:2008 =

2110 South 26th Street
PO Box 1720
Manitowoc, WI 54221-1720 USA

Tel: 1.920.682.0161
Fax: 1.920.683.7589

www.manitowocice.com



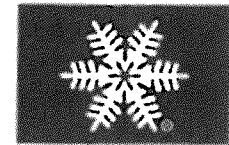

NEO® 140/190 Undercounter Ice Machines

U-140
U-190

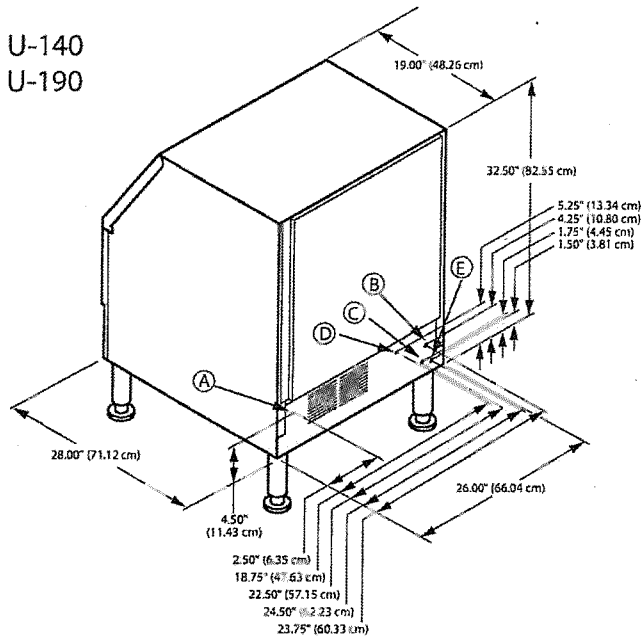

Installation Note Recommended clearance for top, sides, and back is 5" (12.7 cm) however, there is no minimum clearance required.

- (A) Electrical Entrance
- (B) 3/8" (0.95 cm) F.P.T. Ice Making Water Inlet
- (C) 1/2" (1.27 cm) F.P.T. Minimum Water Condenser Outlet (water-cooled units)
- (D) 3/8" (0.95 cm) F.P.T. Water Condenser Inlet (water-cooled units)
- (E) 1/2" (1.27 cm) F.P.T. Ice Bin Drain

Specifications

Model	Ice Shape	Ice Production 24 Hours				Power kWh/ 100 lbs. @ 90°/70°F 32°/21°C	Potable water usage gal/100 lbs. ice @ 90°/70°F	ENERGY STAR®
		70°Air/50°F Water 21°Air/10°C Water	90°Air/70°F Water 32°Air/21°C Water					
UR-0140A	regular	122 lbs	59 kg	90 lbs	41 kg	11.3	23.3	★
UD-0140A	dice	129 lbs	59 kg	95 lbs	43 kg	11.1	24.4	★
UD-0140W	dice	135 lbs	61 kg	104 lbs	49 kg	9.4	23.8	NA
UY-0140A	half-dice	132 lbs	60 kg	95 lbs	43 kg	11.1	24.9	★
UY-0140W	half-dice	126 lbs	57 kg	104 lbs	43 kg	9.4	22.9	NA
UR-0190A	regular	188 lbs	85 kg	133 lbs	60 kg	8.7	21.3	★
UD-0190A	dice	198 lbs	90 kg	140 lbs	64 kg	8.4	23.9	★
UY-0190A	half-dice	193 lbs	89 kg	140 lbs	64 kg	8.3	21.6	★

Water-cooled Condenser Water Usage / 100 lbs./45.4 kg of Ice: 185 gal. / 700 liters

Water-cooled models are excluded from ENERGY STAR qualification.

Air Flow

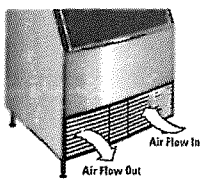

Air in right, air out left, no side vents. Great for installation under countertops and next to other equipment.

Removable Bin

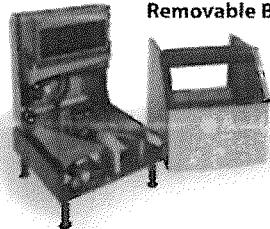

Air Filter

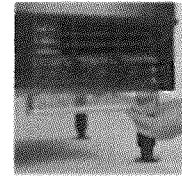

Simple, tool-free removal for quick access during routine cleaning and maintenance.

2110 South 26th Street
PO Box 1720
Manitowoc, WI 54221-1720 USA

Tel: 1.920.682.0161
Fax: 1.920.683.7589
www.manitowocice.com



5069H © 2015 Manitowoc #15 Continuing product improvement may necessitate change of specifications without notice.