

# Concept 02 (5'): 3D view

18 WANE 210573



RECEIVED  
FEB 21 2019  
POPULOUS  
DESIGN SERVICES

# Concept 02 (5'): 3D view



RECEIVED  
FEB 11 2019  
PLANNING &  
DESIGN SERVICES

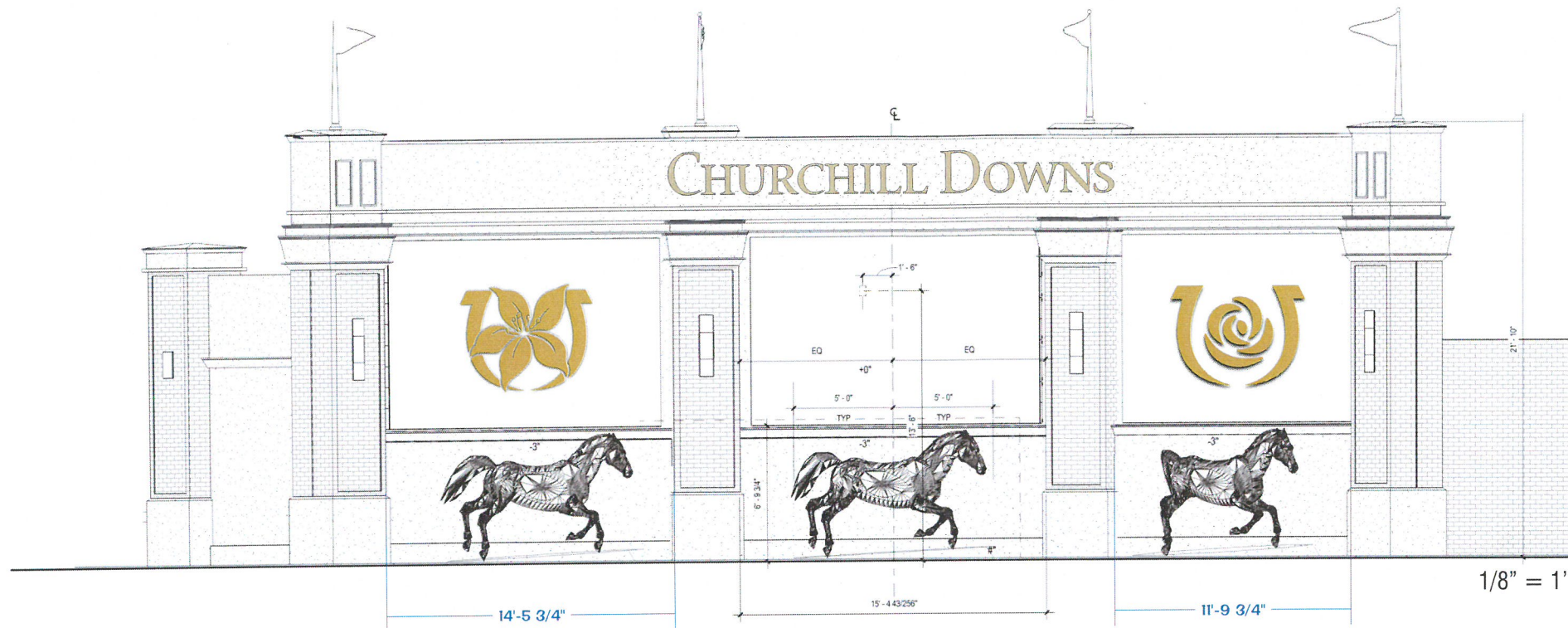

3/8" = 1'

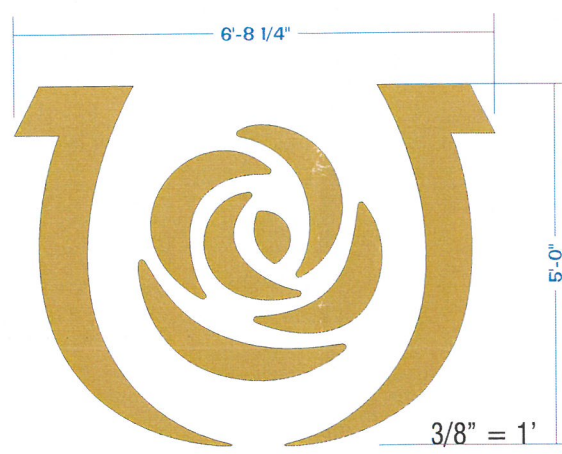

3/8" = 1'

**Wall Mounted Channel Letters** END VIEW  
**LED Internal Illumination** Not To Scale

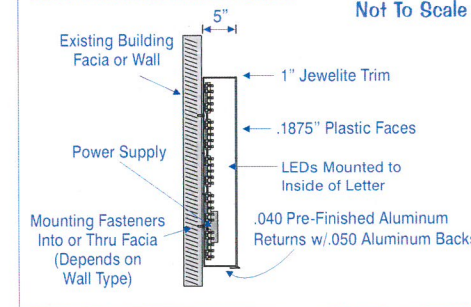

Channel Letters - Flush Mount  
 Letter Colors: Letter Faces, As Shown  
 Returns, Match Faces  
 Jewelite Trim, Black  
 For Construction Details See End View Insert.

**RSI**  
**RUEFF SIGNS**  
 www.rueffsigns.com

1530 East Washington St.  
 Louisville, Kentucky 40206  
 502-582-1714 - Phone  
 502-584-6427 - Fax

**CUSTOMER**

Churchill Downs

**LOCATION**

Churchill Downs

**SALESMAN**

Bob Rueff

**DATE**

1-17-19

**SCALE**

As Shown

**FILE NAME**

Churchill Downs \ 2019 \ Radius Corner Channel Letters



ALL ELECTRICAL SIGNS ARE 120 VOLTS UNLESS OTHERWISE INDICATED

This sign is intended to be installed in accordance with the requirements of Article 600 of the National Electrical Code and/or other applicable local codes. This includes proper grounding and bonding of the sign.

This is a sketch, NOT A BLUEPRINT. Any photo overlays or images are merely an attempt to show the sign(s) as close as possible to how they may appear installed.

FINAL SIZES ARE AS LISTED ON THE MECHANICAL BREAKDOWN.

The contents of this drawing and all design elements are the property of Rueff Signs, Inc. They are not to be reproduced, changed, or exhibited to anyone outside of your company in whole or in part without written permission from the owner of Rueff Signs, Inc. All such actions are prohibited by law.

© RUEFF SIGNS, 2018 ALL RIGHTS RESERVED

RECEIVED  
 FEB 11 2019  
 DESIGN SERVICES

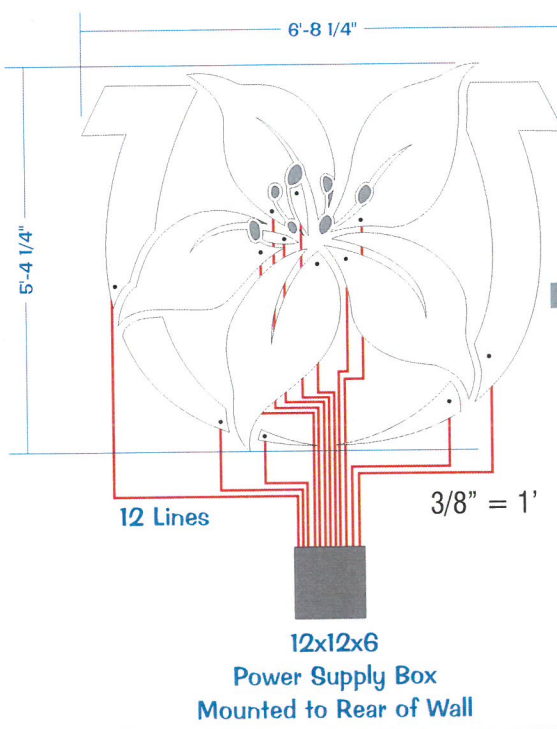
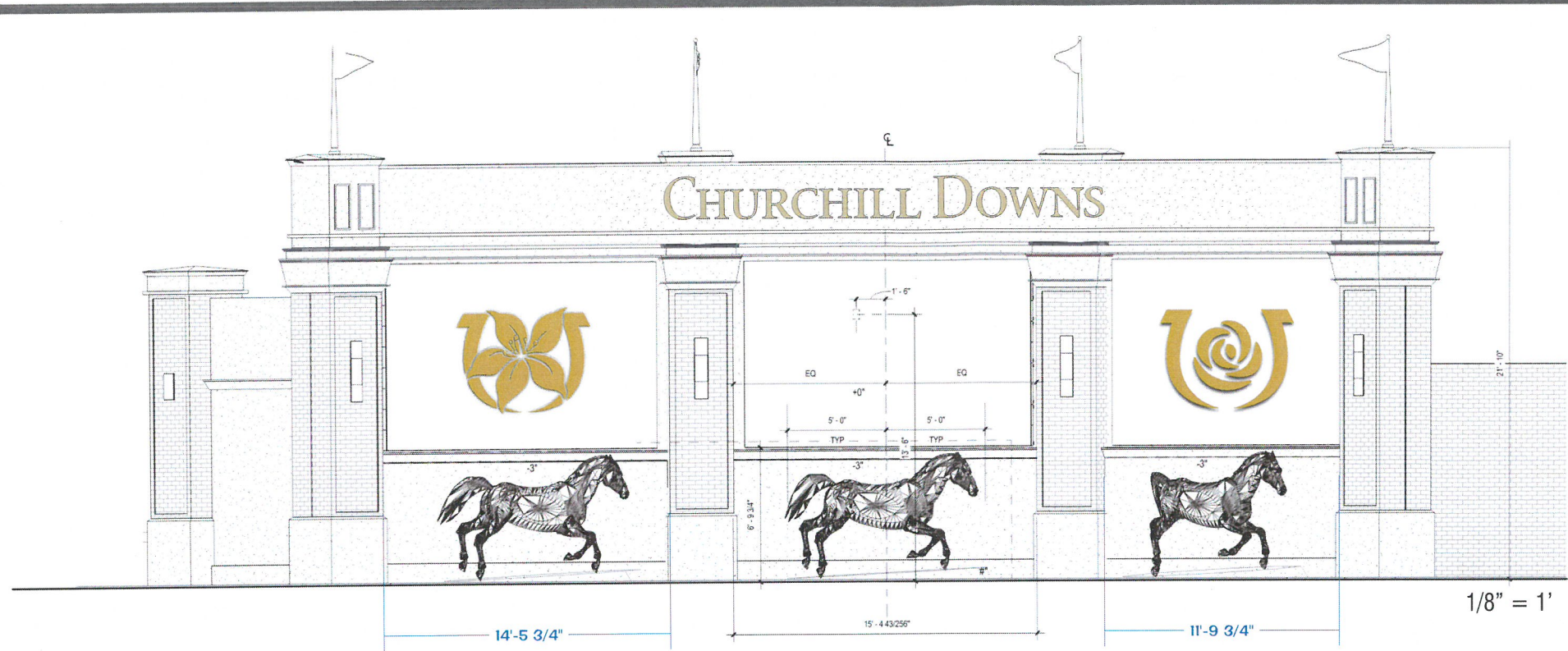

Grey Denotes Pieces too small to light

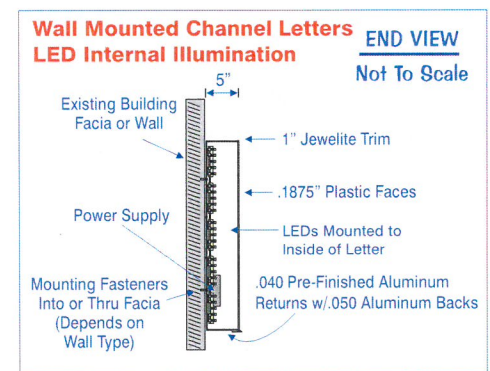
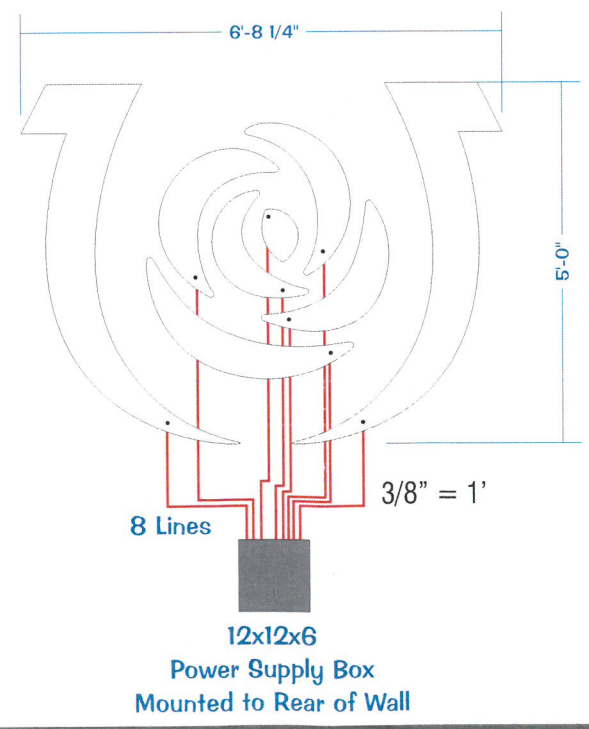

**Channel Letters - Flush Mount**  
**Letter Colors:** Letter Faces, As Shown  
 Returns, Match Faces  
 Jewelite Trim, Black  
 For Construction Details See End View Insert.

**RSI**  
**RUEFF SIGNS**  
 www.rueffsigns.com

1530 East Washington St.  
 Louisville, Kentucky 40206  
 502-582-1714 - Phone  
 502-584-6427 - Fax

**CUSTOMER**

Churchill Downs

**LOCATION**

Churchill Downs

**SALESMAN**

Bob Rueff

**DATE**

1-17-19

**SCALE**

As Shown

**FILE NAME**

Churchill Downs \ 2019 \ Radius Corner Channel Letters

Underwriters Laboratories Inc.  
 LISTED  
**ELECTRIC SIGN**  
 COMPLIES TO UL 48

ALL ELECTRICAL SIGNS ARE 120 VOLTS UNLESS OTHERWISE INDICATED

This sign is intended to be installed in accordance with the requirements of Article 600 of the National Electrical Code and/or other applicable local codes. This includes proper grounding and bonding of the sign.

This is a sketch, NOT A BLUEPRINT. Any photo overlays or images are merely an attempt to show the sign(s) as close as possible to how they may appear installed.

FINAL SIZES ARE AS LISTED ON THE MECHANICAL BREAKDOWN.

The contents of this drawing and all design elements are the property of Rueff Signs, Inc. They are not to be reproduced, changed, or exhibited to anyone outside of your company in whole or in part without written permission from the owner of Rueff Signs, Inc. All such actions are prohibited by law.

© RUEFF SIGNS, 2018 ALL RIGHTS RESERVED

RECEIVED

FEB 11 2019  
 DESIGN SERVICES

1819111901053

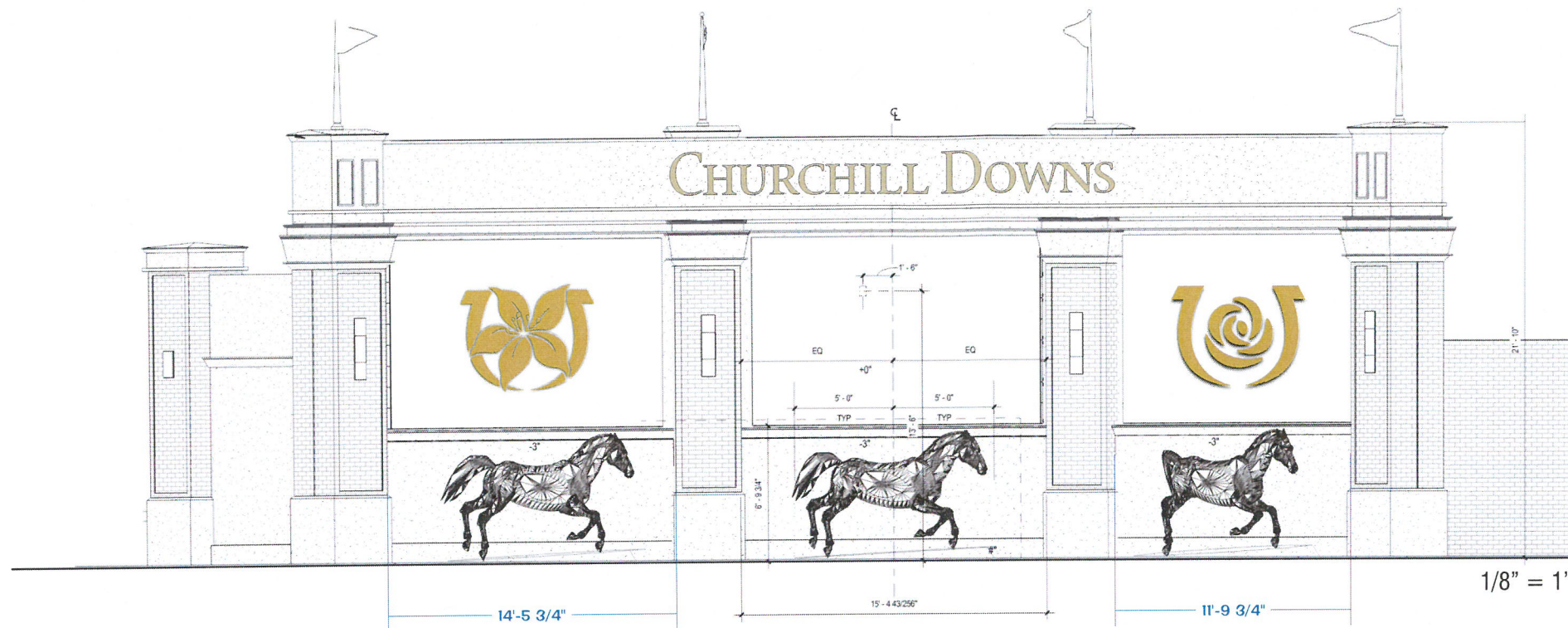

22'-4 3/4"

# CHURCHILL DOWNS

3/8" = 1'

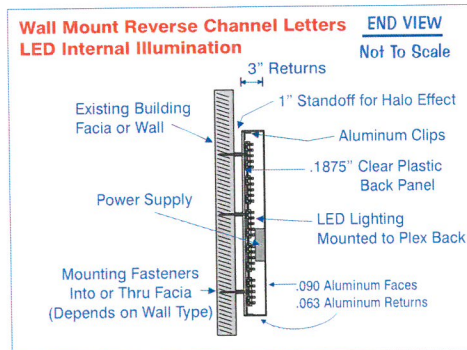

**Internally Illuminated Reverse Channel Letters.**  
**Standoff Mounted to Facilitate Back Lighting Effect.**  
**Colors: Faces, Bright Gold**  
**Returns, Bright Gold**  
**For Details See End View Insert.**

**RUEFF SIGNS**  
 www.rueffsigns.com

1530 East Washington St.  
 Louisville, Kentucky 40206  
 502-582-1714 - Phone  
 502-584-6427 - Fax

<b>CUSTOMER</b>	Churchill Downs
<b>LOCATION</b>	Churchill Downs
<b>SALESMAN</b>	Bob Rueff
<b>DATE</b>	1-17-19
<b>SCALE</b>	As Shown
<b>FILE NAME</b>	Churchill Downs \ 2019 \ Radius Corner Channel Letters

ALL ELECTRICAL SIGNS ARE 120 VOLTS UNLESS OTHERWISE INDICATED

This sign is intended to be installed in accordance with the requirements of Article 600 of the National Electrical Code and/or other applicable local codes. This includes proper grounding and bonding of the sign.

This is a sketch, NOT A BLUEPRINT. Any photo overlays or images are merely an attempt to show the sign(s) as close as possible to how they may appear installed.

FINAL SIZES ARE AS LISTED ON THE MECHANICAL BREAKDOWN.

The contents of this drawing and all design elements are the property of Rueff Signs, Inc. They are not to be reproduced, changed, or exhibited to anyone outside of your company in whole or in part without written permission from the owner of Rueff Signs, Inc. All such actions are prohibited by law.

© RUEFF SIGNS, 2018 ALL RIGHTS RESERVED

RECEIVED  
 FEB 17 2019  
 DESIGN SERVICES

18WAIVER1053

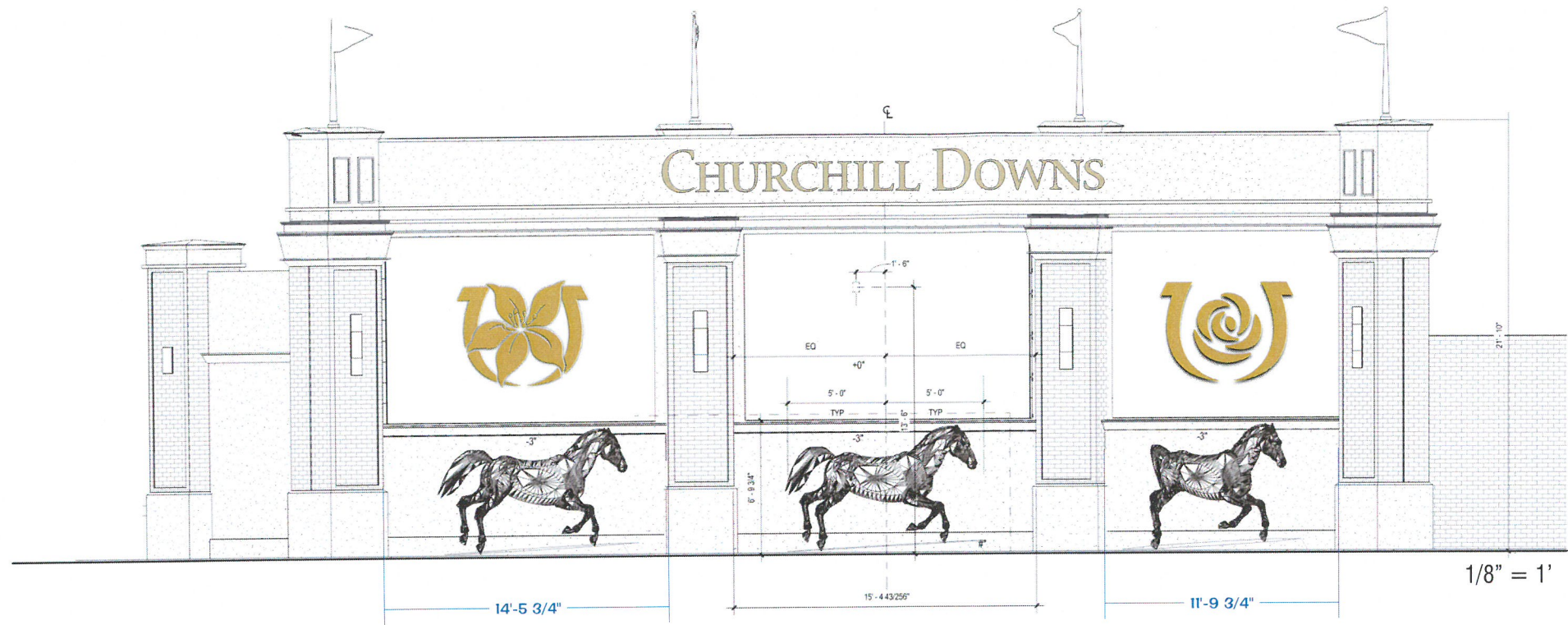

CHURCHILL DOWNS

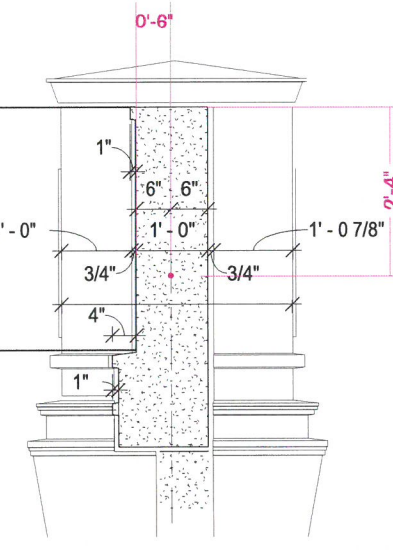

12x12x6  
Power Supply Box  
Mounted to Rear of Column

12x12x6  
Power Supply Box  
Mounted to Rear of Column

**RSI**  
**RUEFF SIGNS**  
www.rueffsigns.com

1530 East Washington St.  
Louisville, Kentucky 40206  
502-582-1714 - Phone  
502-584-6427 - Fax

**CUSTOMER**

Churchill Downs

**LOCATION**

Churchill Downs

**SALESMAN**

Bob Rueff

**DATE**

1-17-19

**SCALE**

As Shown

**FILE NAME**

Churchill Downs \ 2019 \ Radius Corner Channel Letters

**UL** Underwriters Laboratories Inc.  
LISTED  
**ELECTRIC SIGN**  
COMPLIES TO UL 48

ALL ELECTRICAL SIGNS ARE 120 VOLTS UNLESS OTHERWISE INDICATED

This sign is intended to be installed in accordance with the requirements of Article 600 of the National Electrical Code and/or other applicable local codes. This includes proper grounding and bonding of the sign.

This is a sketch, NOT A BLUEPRINT. Any photo overlays or images are merely an attempt to show the sign(s) as close as possible to how they may appear installed.

FINAL SIZES ARE AS LISTED ON THE MECHANICAL BREAKDOWN.

The contents of this drawing and all design elements are the property of Rueff Signs, Inc. They are not to be reproduced, changed, or exhibited to anyone outside of your company in whole or in part without written permission from the owner of Rueff Signs, Inc. All such actions are prohibited by law.

© RUEFF SIGNS, 2018 ALL RIGHTS RESERVED

RECEIVED

FEB 11 2019  
DESIGN SERVICES

10W DIVER 1053

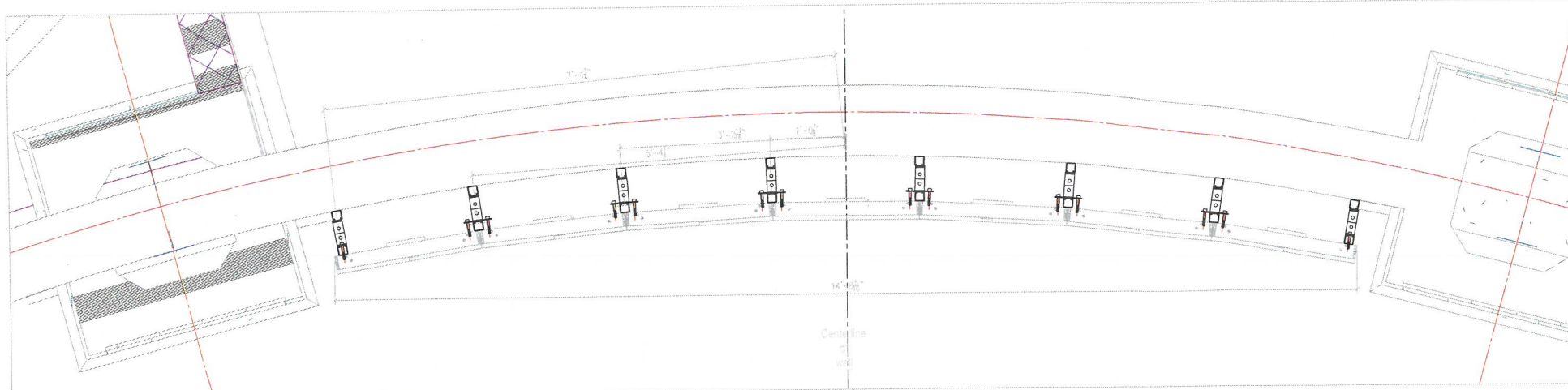

A. Strut Attachment, plan view

Attachment is symmetrical across centerline, dimensions typical of either side shown  
 1/4" = 1'-0"

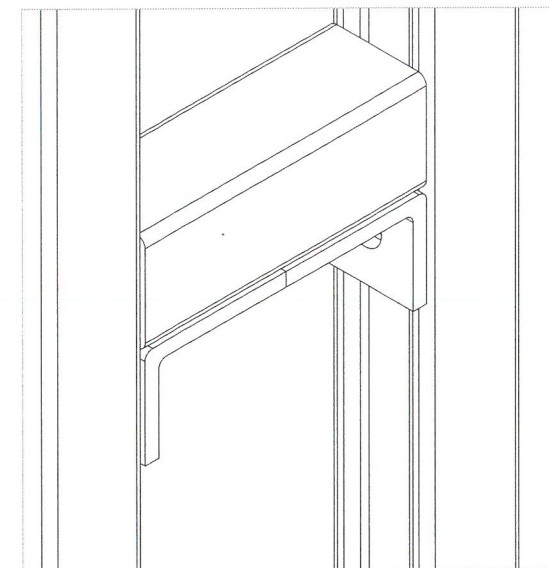

C. Isometric Detail - Strut Assembly

Full Scale  
 Strut shall be 6-Line B225H SS- stainless steel or equal. Brackets shall be 6-Line 3101 SS- or equal.  
 1-14 stainless fasteners including channel nuts, shall be used. Tighten fasteners to 300 lbs per 6-Line specification.

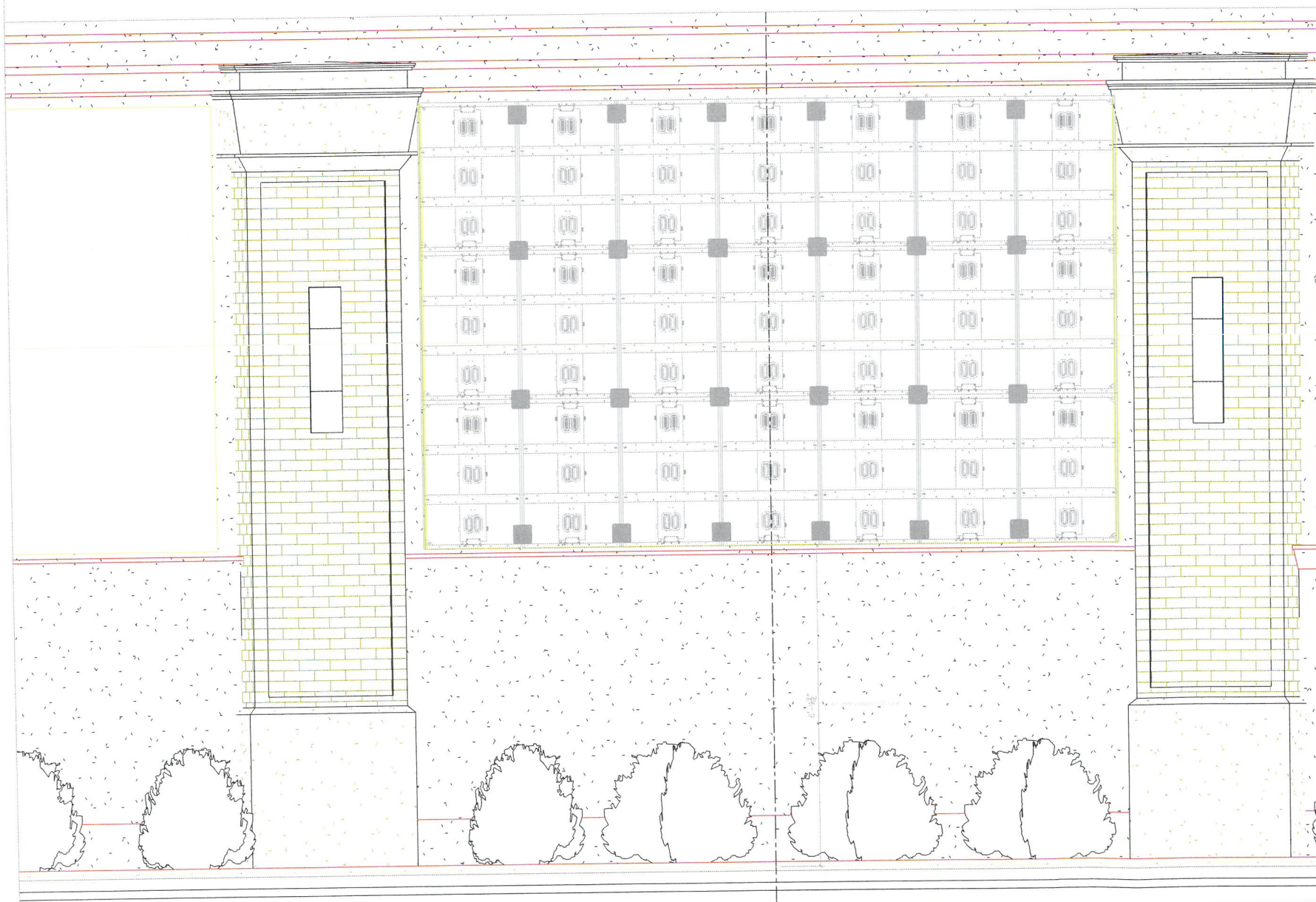

B. Strut Attachment, elevation / projection

SHOWN FOR REFERENCE OF VERTICAL PLACEMENT ONLY.  
 DUE TO CURVATURE OF PROJECTION, DO NOT SCALE LATERALLY. 1/4" = 1'-0"

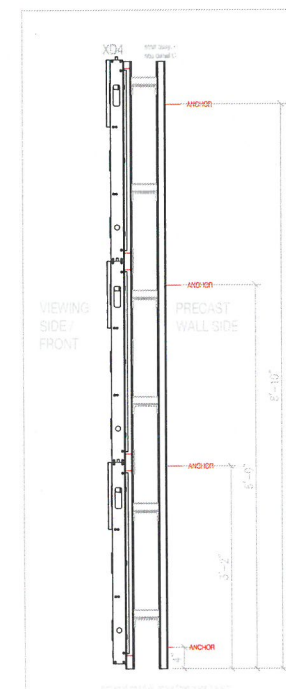

D. Side View, typical of 8 assemblies

Each 6-Line 6-8 strut shall have no more than 200 lbs attachment to precast to be determined by precast manufacturer's offers.

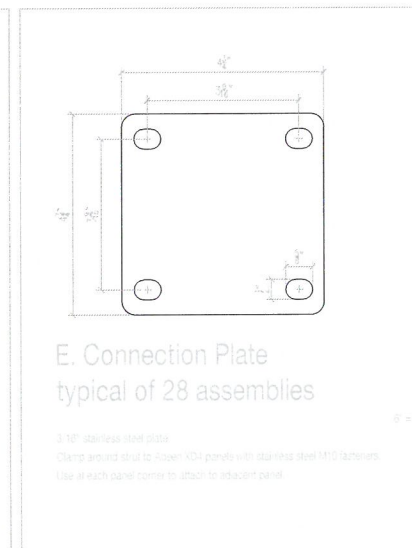

E. Connection Plate typical of 28 assemblies

3/16" stainless steel plate  
 Drill around strut to insert N24 panels with stainless steel 1/16" fasteners  
 Use at each panel corner to attach to adjacent panel

CHURCHILL DOWNS  
 INFIELD GATE

700 Central Ave, Louisville KY, 40208

REVISIONS		
#	DESCRIPTION	DATE
A	Initial Shop Drawing	1/2/19
B	Revised with new mounting method	1/4/19
C	Revised from comments	1/7/19

LED Wall  
 Shop Drawings

RECEIVED

FEB 11 2019

DESIGN SERVICES



SOUND IDEAS  
 3500 APPLE HILL RD  
 LOUISVILLE, KY 40245  
 WWW.YOURSOUNDIDEAS.COM

Wall Attachment Plan

DRAWN BY: CMP	DATE: 1/4/19	DRAWING #: V-5.0
CHECKED BY:	SCALE:	

18W/18V 1053