

Received: 6-16-14 @ 9:20am

**NEIGHBORHOOD DEVELOPMENT FUND
Not-for-Profit Transmittal and Approval Form**

Applicant/Program: Schnitzelburg Area Community Council (SACC)

Executive Summary of Request:

To fund a capital project called Three Points Beautification Project which is a component of a larger Goss Avenue Corridor Improvement. This project includes a mural, landscaping, benches, and trash receptacle. This will enhance the revitalization project already underway in the community to improve functionality to residents in the area.

Is this program/project a fundraiser? Yes No
Is this applicant a faith based organization? Yes No
Does this application include funding for sub-grantee(s)? Yes No

I have reviewed the attached Neighborhood Development Fund Application and have found it complete and within Metro Council guidelines and request approval of funding in the following amount(s). I have read the organization's statement of public purpose to be furthered by the funds requested and I agree that the public purpose is legitimate. I have also completed the disclosure section below, if required.

10 District # Jim King Primary Sponsor Signature \$ 4,000 Amount 6/5/14 Date

Primary Sponsor Disclosure
List below any personal or business relationship you, your family or your legislative assistant have with this organization, its volunteers, its employees or members of its board of directors.

Approved by:

Appropriations Committee Chairman Date

Clerk's Office Only:
Request Amount: _____ Committee Amended Appropriation: _____
Original Appropriation: _____ Council Amended Appropriation: _____

OFFICE OF METRO COUNCIL CLERK
REVIEWED

DATE 7-1-14 TIME 12:20pm

Applicant/Program: SACC

Additional Disclosure and Signatures

Additional Council Office Disclosure

List below any personal or business relationship you, your family or your legislative assistant have with this organization, its volunteers, its employees or members of its board of directors.

<u>4</u> District #	 Council Member Signature	<u>\$2500</u> Amount	_____ Date
_____ District #	_____ Council Member Signature	_____ Amount	_____ Date
_____ District #	_____ Council Member Signature	_____ Amount	_____ Date
_____ District #	_____ Council Member Signature	_____ Amount	_____ Date
_____ District #	_____ Council Member Signature	_____ Amount	_____ Date
_____ District #	_____ Council Member Signature	_____ Amount	_____ Date
_____ District #	_____ Council Member Signature	_____ Amount	_____ Date



LOUISVILLE METRO COUNCIL

NEIGHBORHOOD DEVELOPMENT FUND APPLICATION



SECTION 1 - APPLICANT INFORMATION

Legal Name of Applicant Organization: Schnitzelburg Area Community Council (SACC)
(as listed on: <http://www.sos.ky.gov/business/records/>)

Main Office Street & Mailing Address: P.O. Box 17306 Louisville, Kentucky 40217

Website: schnitzelburg.blogspot.com

Application Contact: Jennifer Chappell

Title: SACC Board Member; Three Points Project Manager

Phone: 502.641.7534

Email: jnnfr.r.chppll@gmail.com

Financial Contact: Kathy Lang

Title: SACC Board Member; Treasurer

Phone: 502.931.2014

Email: klang1033@gmail.com

GEOGRAPHICAL AREA(S) WHERE PROGRAM ACTIVITIES ARE (WILL BE) PROVIDED

Program Facility Location(s): Intersection of Goss Avenue and Logan Street (including Abell Elevator Building - 1256 Logan Street)

Council District(s): 4 (on boundary of 10)

Zip Code(s): 40204

SECTION 2 - PROGRAM REQUEST & FINANCIAL INFORMATION

Program Name: Three Points Beautification Project

Total Request: \$6,500.00

Total Metro Award (this program) in previous year : \$0

The following are required attachments:

- IRS Exempt Status Determination Letter
- Current Year Projected Budget
- List of Board of Directors (include term & term limits)
- Current financial statement
- Most recent IRS Form 990 or 1120-H
- Articles of Incorporation
- Cost estimates from proposed vendor if request is for capital expense
- Signed lease if rent costs are being requested
- IRS Form W9
- Evaluation forms if used in the proposed program
- Annual audit (if required by organization)
- Faith Based Organization Certification Form, if required
- Staff including the 3 highest paid staff

Agency Fiscal Yr Start Date: July 1st

For the current fiscal year ending June 30, list all funds received from Louisville Metro Government for this or any other program or expense, including funds received through Metro Federal Grants, from any department or Metro Council Appropriation (Neighborhood Development Funds). Attach additional sheet if necessary.

Source: NDP j. Chappell **Amount:** \$ 4,820.07

Source: **Amount:** \$

Source: **Amount:** \$

Has the applicant contacted the BBB Charity Review for participation? Yes No

Has the applicant met the BBB Charity Review Standards? Yes No

SECTION 3 - SIGNATURE

I certify under the penalty of law the information in this application (including, without limitation, the "Certifications and Assurances") is accurate to the best of my knowledge. I am aware my organization will not be eligible for funding if investigation at any time shows falsification. If falsification is shown after funding has been approved, any allocations already received and expended are subject to be repaid. I further certify that I am legally authorized to sign this application for the applying organization.

Signature of Legal Signatory: *J. Chappell*

Date: May 28th, 2014

Legal Signatory (please print): Jennifer Chappell

Title: SACC Board Member

Phone: 502.641.7534 **Extension:**

Email: jnnfr.r.chppll@gmail.com

SECTION 4 - AGENCY DETAILS

Describe Agency's Vision, Mission and Services:

See attached documents for answers to questions, project proposal, and supporting documents.

SECTION 5 - PROGRAM NARRATIVE

A: Purpose of Request (check all that apply):

- Operating Funds (generally cannot exceed 33% of agency's total operating budget)
- Programming/services/events for direct benefit to community or qualified individuals
- Capital Project of the organization (equipment, furnishing, building, etc)

B: Describe the program/project start and end dates, a description of the program/project and applicable data with regards to specific client population the program will address (attach related flyers, planning minutes, designs, event permits, proposals for services/goods, etc):

See attached for answers to questions, project proposal, and supporting documents.

C: Describe specifically how the funding will be spent including identification of funding to subgrantee(s):

See attached for answers to questions, project proposal, and supporting documents.

D: For Expenditure Reimbursement Only - The grant award period begins with the Metro Council Appropriation Committee approval date and ends on June 30 of the fiscal year in which the grant is approved. If any part of this funding request is for funds that will be spent before the grant award period, identify the applicable circumstances:

- The funding request is a reimbursement of the following expenditures that have occurred prior to the application date:
- ✓ Attach a copy of invoices and/or receipts to provide proof of purchase of activities associated with the work plan identified in this application.
 - ✓ Attach a copy of cancelled checks to provide proof of payment of the invoices or receipts associated with the work plan identified in this application.

n/a

- The funding request is a reimbursement of the following expenditures that will be incurred after the application date, but prior to the Metro Council approval date. This option will allow expenditures occurring within this time frame to be considered compliant with the grant agreement.
- ✓ If selecting this option, the invoice, receipt and payment documentation should not be available as of the date of this application.
 - ✓ The Grantee will be required to submit financial reporting in accordance with the reporting schedule provided in the grant agreement.

n/a

E: If this request is for a fundraiser, please detail how the proceeds will be spent:

n/a

F: Briefly describe any existing collaborative relationships the organization has with other community organizations. Describe what those partners are bringing to the relationship in general and to this program specifically.

See attached for answers to questions, project proposal, and supporting documents.

G: Describe the program's benefits to those being served (measurable outcomes). Include the program's process for collecting data and the indicators that will be tracked to measure the benefits to those being served:

See attached for answers to questions, project proposal, and supporting documents.

SECTION 6 - PROGRAM BUDGET SUMMARY

The Program Budget should realistically estimate what amount is needed from Metro Government and what is expected from other sources. **Enter whole-dollar amounts.**

	Column 1	Column 2*	Column 3
Program Expenses	Proposed Metro Funds	Non- Metro Funds	Total Program Cost
A: Personnel Costs Including Benefits	\$0.00	\$0.00	\$0.00
B: Rent/Utilities	\$0.00	\$0.00	\$0.00
C: Office Supplies	\$0.00	\$100.00	\$100.00
D: Telephone	\$0.00	\$0.00	\$0.00
E: In-town Travel	\$0.00	\$0.00	\$0.00
F: Client Assistance (Attach Detailed List)	\$0.00	\$0.00	\$0.00
G: Professional Service Contracts	\$5,000.00	\$0.00	\$5,000.00
H: Program Materials	\$0.00	\$0.00	\$0.00
I: Community Events & Festivals (Attach Detailed List)	\$0.00	\$0.00	\$0.00
J: Machinery & Equipment	\$0.00	\$100.00	\$100.00
K: Capital Project	\$1,500.00	\$1,560.00	\$3,060.00
L: Other Expenses (Attach Detail List)	\$0.00	\$5,496.90	\$5,496.90
SUBTOTAL	\$6,500.00	\$7,256.90	\$13,756.90
% of Program Budget –	47 %	53 %	100%
Value of volunteer services and how computed:	N/A		
Value of in-kind assets, such as donated space, supplies, use of equipment, etc. <i>(Detail on Next Page)</i>	N/A		
Total Program Funds	\$6,500.00	\$7,256.90	\$13,756.90

*List funding sources in Column 2 (do not include individual donor names):

Other State, Federal or Local Government	\$0.00
United Way	\$0.00
Private Contributions	Donations through Neighbor.ly
Fees Collected from Program Participants	\$0.00
Other (please specify)	\$0.00
Total Revenues	To Be Determined

PROGRAM BUDGET SUMMARY (CONTINUED)

Detail of In-Kind Contributions for this PROGRAM only: Includes Volunteers, Space, Utilities, etc. (Include anything not bought with cash revenues of the agency).

Donor*/Type of Contribution	Value of Contribution	Method of Valuation
Abell Elevator Company - Wall for Mural	\$0.00	Value of wall space cannot be determined.
Community Volunteers - Prime mural wall and trash pick-up	\$725.00	Estimate for 100 hours worked at \$7.25 an hour (minimum wage)
M3 Solutions - Concreet Pad for Bench	\$200.00	Average cost per square foot of installation = \$8.04 + labor
Total Value of In-Kind <i>(to match Program Budget Line Item.</i> Volunteer Contribution & Other In Kind)	\$925.00	

* Donor information refers to who made the in kind contribution. Volunteers need not be listed individually, but grouped together on one line as a total noting how many hours per person per week)

Does your Agency anticipate a significant increase or decrease in your budget from the current fiscal year to the budget projected for next fiscal year? NO YES

If YES, please explain:

See attached for additional information even though answer is "no."

SECTION 7 - CERTIFICATIONS AND ASSURANCES

By signing the first page of the Grant Application, the authorized official signing for the applicant organization certifies and assures to the best of his or her knowledge and/or belief the following Assurances and Certifications. If there is any reason why one or more of the assurances or certifications listed cannot be certified or assured, please explain in writing and attach to this application.

Standard Assurances

1. Applicant understands this application and its attachments as well as any resulting grant agreement, reports and proof of expenditure is subject to Kentucky's open records law.
2. Applicant will establish safeguards to prohibit employees or any person that receives compensation from awarded funds from using their position for a purpose that constitutes or presents the appearance of personal or organizational conflict of interest, or personal gain.
3. Applicant and any sub grantee will give Louisville Metro Government access to and the right to examine all paper or electronic records related to the awarded grant for up to five years of the grant agreement date.
4. Applicant assures compliance with the grant requirements and will monitor the performance of any third party (sub-grantee).
5. The Agency is in good standing with the Kentucky Secretary of State, Louisville Metro Government, the Jefferson County Revenue Commission, the Internal Revenue Service, and the Louisville Metro Human Relations Commission.
6. Failure to provide the services, programs, or projects included in the agreement will result in funds being withheld or requested to be returned if previously disbursed.
7. Return to Louisville Metro any unexpended funds by July 31 following the Metro Louisville's fiscal year end
8. Provide proof of all expenditures (canceled checks, receipts, paid invoices). The Applicant understands the failure to provide proof of expenditures as required in the grant agreement could result in funding being withheld or request to be returned if previously disbursed.
9. Applicant understands if this application is approved, the grant agreement will identify an award period that begins with the Metro Council approval date, and will end with June 30 of the fiscal year in which the grant is approved. Expenditures associated with this award expected to occur prior to the award period (approval date) must be disclosed in this application in order to be considered compliant with the grant agreement.
10. Applicant understands if we choose to incur expenditures prior to the approval of the application by the Metro Council, there is no guarantee that funding will be reimbursed, as the Council may choose not to award the application.

Standard Certifications

1. The Agency certifies it will not use Louisville Metro Government funds for any religious, political or fraternal Activities.
2. The Agency has a written Affirmative Action/Equal Opportunity Policy.
3. The Agency does not discriminate in employment or in provision of any service/program/activity/event based on age, color, disabled status, national origin, race, religion, sex, gender identity or sexual orientation, or Vietnam era veteran status.
4. The Agency certifies it will not require clients, recipients, or beneficiaries to participate in religious, political, fraternal or like activities in order to receive services/benefits provided with Louisville Metro Government funds.
5. The Agency understands the Americans with Disabilities Act (ADA) and makes reasonable accommodations.

Relationship Disclosure: List below any relationship you or any member of your Board of Directors or employees has with any Councilperson, Councilperson's family, Councilperson's staff or any Louisville Metro Government employee.

n/a

Neighborhood Development Fund Application Questions

Section 4 - Agency Details

Describe Agency's Vision, Mission, and Services:

The Three Points Beautification Project idea was conceived at the end of 2013. The project manager for this project is a current serving board member on the Schnitzelburg Area Community Council (SACC) and this project is utilizing the resources and support of the SACC, HOWEVER, the project is a collaboration between the Schnitzelburg Area Community Council (SACC), the German-Paristown Neighborhood Association (GPNA), and the Shelby Park Neighborhood Association (letters of support from each of the neighborhood organizations have been attached). The location of the project is unique as it represents a point in which all three neighborhoods meet, thus spurring the title "Three Points" for the area. Due to the project's goal to highlight the three neighborhoods and beautify an intersection that is used heavily as a gateway between the three neighborhoods, the SACC should not be identified as the sole entity behind the project.

The project seeks to enhance the blighted intersection of Goss Avenue and Logan Street, which is located entirely in Metro Council District 4 (David Tandy) at the edge of District 10 (Jim King). A mural, extensive landscaping, infrastructure improvements, and added amenities are included in the scope of this project. Goals of the project aim to: 1) communicate the cultural and artistic spirit of the surrounding communities, 2) instill community pride in residents, 3) improve walkability, 4) calm traffic at the complex intersection, 5) add to Louisville's tree canopy, 6) and help visitors to the area identify nearby neighborhoods. The three neighborhoods involved in the project have very active community groups, include the "hottest" real estate zip codes in Louisville*, and are home to a plethora of small, locally-owned businesses. As these "trendy" neighborhoods grow, tourists and residents of Jefferson County will seek out the area. This cultural growth is beneficial to both the neighborhoods and the city of Louisville, especially considering the financial benefit of increased investment in small businesses, increased property values, and increase in occupants in the neighborhoods.

A large-scale project, such as this, will show an investment is being made in the community and the future and well-being of residents is being considered. It is a strong belief that this project will encourage others to act in good will with embracing more community enhancing projects and to take care of what already exists. Positivity spurs positivity.

This project is located directly outside of the former Goss Avenue Antique Mall/Cotton Mill. There is currently a massive renovation project to convert the old factory into the Germantown Mill Lofts - 180+ loft style apartments developed by Underhill Associates. This will garner a lot more visibility for the already heavily trafficked intersection of the proposed project. The SACC and GPNA are also working together on the Goss Avenue Beautification Project that seeks to improve/update Goss Avenue and make it a bustling "Main Street." Goss Avenue ends at the location of the Three Points Beautification Project (just over the railroad tracks) and the project is clearly seen while looking Northwest, directly down Goss Avenue. This project will compliment the Germantown Mill Lofts Project, the Goss Avenue Beautification, and the other revitalization projects underway and planned in the area.

The Three Points Beautification Project accomplishes the goals for public purpose, as identified by Louisville/Jefferson County Metro Government: promotion of public health, safety, general welfare, security, prosperity, and contentment of residents within the jurisdiction of Metro Louisville.

*Kaufman, Steve. "Louisville Home Sales Hopping, Especially in 40204." *Insider Louisville*. Insider Louisville, 17 Apr. 2014. Web. 28 May 2014. <<http://insiderlouisville.com/business/louisville-home-sales-hopping-especially-40204/>>.

Section 5 - Program Narrative

B. Describe the program/project start and end dates, a description of the program/project and applicable data with regards to specific client population the program will address:

The project was started in December of 2013 has been in development since. The physical transformation of the intersection will begin in mid July 2014. Landscapers will begin edging and clearing the area of debris during this time. Volunteers from SACC, GPNA, and SPNA will paint the wall with primer at this time as well. The actual mural will be painted between July 28th and August 3rd. Final landscaping will occur after in August when the mural is complete. Bench and trash can installation is dependent on materials being delivered to the site, although the concrete pad that is to be poured on Save-a-Lot's property for anchoring the bench will be completed in mid to late July.

The project serves three neighborhoods directly (German-Paristown, Schnitzelburg, Shelby Park) which, according to 2010 Census data, is comprised of about 46,437 residents. These residents reflect about 7.8% of Louisville Metro's total population.

Attached are 2010 census populations by zip code, as well as USPS information on how many households/businesses are represented by the three neighborhoods based on mail routes.

C. Describe specifically how the funding will be spent, including identification of funding to subgrantee(s):

The cost of funds from Louisville Metro (\$6,500 in total; \$4,000 from Jim King and \$2,500 from David Tandy) will be allocated to the mural design, painting and paint supplies, and the landscaping portion of the project.

Artist Fees: \$3,000.00

Paint/Paint Supplies**: \$ 3,060.00

Landscaping: \$2,000.00

Total: \$8,060.00

Obviously, the full amount received from Louisville Metro Neighborhood Development Funds will not be enough to cover the entire scope of this part of the project, but funds will be solicited via an online

crowd-sourcing fundraising campaign to fill in budget holes. The community will be responsible for funding the completion of this project, making it a truly community supported project.

See attached proposal for full budget.

**Paint costs are estimates and full cost will not be determined until the mural is completed. If paint is purchased and unused, it will be sold back to the paint supplier at the cost in which it was purchased.

F. Briefly describe any existing collaborative relationships the organization has with other community organizations. Describe what those partners are bringing to the relationship in general and to this project specifically:

The project will be working closely with the board members of the German-Paristown Neighborhood Association, Schnitzelburg Area Community Council, and the Shelby Park Neighborhood Association. All neighborhood organizations have had the Three Points Beautification Project discussed at each group's respective open, general public meetings. The project has been well received by all who have heard the proposal. The community will be invited to donate money to the project to fill budget holes or volunteer their time during the actual beautification (volunteers will be priming the wall and cleaning up trash in the area). The project is also a student project for the 2014 Center for Neighborhood's Neighborhood Institute. Outcomes for the project will be shared with future students and through Center for Neighborhood's newsletter and social media platforms.

All other companies involved with the project (Dages Paint, Luv-It Landscaping, M3 Solutions) have been selected in respect to their business being located within the bounds of the project and are in good standing with the three aforementioned neighborhood organizations***. The donation of a trash receptacle by Save-a-lot will help reduce trash in the heavily littered area, and their donation of a bench will show their business is investing in the betterment of the community. Depending on the trash receptacle Save-a-lot decides to donate (given quotes for both a single compartment or tri-compartment receptacle), Feed the Dirt, a local composting organization, will hopefully be able to have a composting bin for organic waste and signage that educates the public on taking a greener approach to what they throw away. Various collaborations with Feed the Dirt are being worked out, but they will definitely be donating compost for the landscaping aspect of the project.

*** The supplier of the bench and trash receptacle is not based in Kentucky, however, it is the supplier that was referred to the project manager by entities of Louisville Metro government. All Recreation is the supplier for the amenities in Emerson Park and for the Goss Avenue Beautification Project. The Three Points Project would like to maintain a cohesive aesthetic with the efforts already underway in the area.

G. Describe the programs benefits to those being served (measurable outcomes). Include the program's process for collecting data and the indicators that will be tracked to measure the benefits to those being served:

Data for this project will be more qualitative, rather than quantitative. Before, during, and after pictures will be taken to show the improvement of the area and use of these photos will be accessible to anyone

involved in the project, including Metro Council. A website is being constructed to show the progress and outcome for the project that will better inform the general public of what is going on with the space. The entirety of the project is open for comments and/or questions. The project will be shared heavily on various social media platforms, especially the Facebook pages of each neighborhood organization and the SACC blog. Social media will be monitored for any comments, questions, and/or reactions.

After completion of the project, a “grand reveal” block party will be planned for the public to view the final project. All neighborhood organizations will have representation present, and possibly booths to provide more information about their respective organizations. News outlets and other entities (including Metro Council and their aids) will be invited to partake in the ceremony, giving further documentation that the project has been completed and the public supports the project.

Community input will be solicited via community meetings following the completion of the project in the fall. Questionnaires could possibly be utilized to gauge community satisfaction and gain other information that would be pertinent to Metro Council, the community organizations, or for planning of future projects. It would also be a benefit to meet with local businesses and see if their business has been affected by the beautification. One business owner in the area thinks the mural will be a great landmark, or relative location, for giving directions and could help funnel traffic to certain areas, especially if a visitor is coming from downtown.

We will also be able to observe increased investment and maintenance of surrounding properties. Investment in this area will have a positive correlation to other projects underway or being conceived in the area. Over time, property values will rise, population in the three neighborhood areas will increase, more small businesses will sprout up, and more investments will be made to the infrastructure of the area. These outcomes will be observed over many years.

Section 6 - Program Budget Summary

Does your Agency anticipate a significant increase or decrease in your budget from the current fiscal year to the budget projected for the next fiscal year?

Three Points Beautification funds will be funneled through the Schnitzelburg Area Community Council's PNC Bank account. As it is a capital project serving three neighborhood organizations, the project is being completed without conjunction to the Schnitzelburg Area Community Council's annual operating budget. This project should not reflect in a change to the operating budget of the Schnitzelburg Area Community Council. Any financial questions pertaining to the Schnitzelburg Area Community Council's budget should be directed toward the SACC treasurer: Kathy Lang (502) 931.2014 klang1033@gmail.com

MAIN	COMMUNITY FACTS	GUIDED SEARCH	ADVANCED SEARCH	DOWNLOAD CENTER
----------------------	---------------------------------	-------------------------------	---------------------------------	---------------------------------

Community Facts - Find popular facts (population, income, etc.) and frequently requested data about your community.

Enter a state, county, city, town, or zip code: 40203

Population (2010 Census)
Population (Latest Estimate)
Age
Business and Industry
Education
Housing
Income
Origins and Language
Poverty
Veterans

40203

Census 2010 Total Population

19,694 Source: 2010 Demographic Profile

Popular tables for this geography:

2010 Census

- General Population and Housing Characteristics (Population, Age, Sex, Race, Households and Housing, ...)
- Race and Hispanic or Latino Origin
- Hispanic or Latino by Type (Mexican, Puerto Rican, ...)
- Households and Families (Relationships, Children, Household Size, ...)

2012 American Community Survey

- Demographic and Housing Estimates (Age, Sex, Race, Households and Housing, ...)

2013 Population Estimates Program

- Annual Population Estimates

Census 2000

- General Demographic Characteristics (Population, Age, Sex, Race, Households and Housing, ...)

• Want more? Use Guided Search or Advanced Search, or visit Census.gov's Quick Facts.

Measuring America — People, Places, and Our Economy

[Accessibility](#) [Information Quality](#) [FOIA](#) [Data Protection & Privacy Policy](#) [U.S. Dept. of Commerce](#)

[What's New](#) [Contact Us](#)

Source: U.S. Census Bureau | American FactFinder

MAIN	COMMUNITY FACTS	GUIDED SEARCH	ADVANCED SEARCH	DOWNLOAD CENTER
----------------------	---------------------------------	-------------------------------	---------------------------------	---------------------------------

Community Facts - Find popular facts (population, income, etc.) and frequently requested data about your community.

Enter a state, county, city, town, or zip code: 40204

Population (2010 Census)
Population (Latest Estimate)
Age
Business and Industry
Education
Housing
Income
Origins and Language
Poverty
Veterans

40204

Census 2010 Total Population

14,236 Source: 2010 Demographic Profile

Popular tables for this geography:

2010 Census

- General Population and Housing Characteristics (Population, Age, Sex, Race, Households and Housing, ...)
- Race and Hispanic or Latino Origin
- Hispanic or Latino by Type (Mexican, Puerto Rican, ...)
- Households and Families (Relationships, Children, Household Size, ...)

2012 American Community Survey

- Demographic and Housing Estimates (Age, Sex, Race, Households and Housing, ...)

2013 Population Estimates Program

- Annual Population Estimates

Census 2000

- General Demographic Characteristics (Population, Age, Sex, Race, Households and Housing, ...)

Want more? Use Guided Search or Advanced Search, or visit Census.gov's Quick Facts.

Measuring America --- People, Places, and Our Economy

[Introduction](#) [Introduction \(audio\)](#) [FAQs](#) [Data Processes & Privacy Policy](#) [U.S. Dept. of Commerce](#)

[What's New](#) [Contact Us](#)

Source: U.S. Census Bureau | American FactFinder

[MAIN](#) | [COMMUNITY FACTS](#) | [GUIDED SEARCH](#) | [ADVANCED SEARCH](#) | [DOWNLOAD CENTER](#)

Community Facts - Find popular facts (population, income, etc.) and frequently requested data about your community.

Enter a state, county, city, town, or zip code: 40217



Population (2010 Census)
Population (Latest Estimate)
Age
Business and Industry
Education
Housing
Income
Origins and Language
Poverty
Veterans

40217

Census 2010 Total Population

12,507 Source: 2010 Demographic Profile

Popular tables for this geography:

2010 Census

- General Population and Housing Characteristics (Population, Age, Sex, Race, Households and Housing, ...)
- Race and Hispanic or Latino Origin
- Hispanic or Latino by Type (Mexican, Puerto Rican, ...)
- Households and Families (Relationships, Children, Household Size, ...)

2012 American Community Survey

- Demographic and Housing Estimates (Age, Sex, Race, Households and Housing, ...)

2013 Population Estimates Program

- Annual Population Estimates

Census 2000

- General Demographic Characteristics (Population, Age, Sex, Race, Households and Housing, ...)

• Want more? Use [Guided Search](#) or [Advanced Search](#), or visit [Census.gov's Quick Facts](#).

Measuring America — People, Places, and Our Economy

[Accessibility](#) | [Information Quality](#) | [FOIA](#) | [Data Protection & Privacy Policy](#) | [U.S. Dept of Commerce](#)

[Download Data](#) | [Census Bureau](#)

Source: U.S. Census Bureau | American FactFinder

State & County QuickFacts

Louisville/Jefferson County (balance), Kentucky

People QuickFacts	Louisville/Jefferson	
	County	Kentucky
Population, 2012 estimate	605,110	4,379,730
Population, 2010 (April 1) estimates base	597,336	4,339,357
Population, percent change, April 1, 2010 to July 1, 2012	1.3%	0.9%
Population, 2010	597,337	4,339,367
Persons under 5 years, percent, 2010	6.7%	6.5%
Persons under 18 years, percent, 2010	23.6%	23.6%
Persons 65 years and over, percent, 2010	12.6%	13.3%
Female persons, percent, 2010	51.6%	50.8%
<hr/>		
White alone, percent, 2010 (a)	70.6%	87.8%
Black or African American alone, percent, 2010 (a)	22.9%	7.8%
American Indian and Alaska Native alone, percent, 2010 (a)	0.3%	0.2%
Asian alone, percent, 2010 (a)	2.2%	1.1%
Native Hawaiian and Other Pacific Islander alone, percent, 2010 (a)	0.1%	0.1%
Two or More Races, percent, 2010	2.3%	1.7%
Hispanic or Latino, percent, 2010 (b)	4.5%	3.1%
White alone, not Hispanic or Latino, percent, 2010	68.3%	86.3%
<hr/>		
Living in same house 1 year & over, percent, 2008-2012	85.6%	84.9%
Foreign born persons, percent, 2008-2012	6.4%	3.2%
Language other than English spoken at home, pct age 5+, 2008-2012	8.3%	4.8%
High school graduate or higher, percent of persons age 25+, 2008-2012	86.7%	82.4%
Bachelor's degree or higher, percent of persons age 25+, 2008-2012	26.5%	21.0%
Veterans, 2008-2012	44,630	319,678
Mean travel time to work (minutes), workers age 16+, 2008-2012	22.2	22.7
Housing units, 2010	270,928	1,927,164
Homeownership rate, 2008-2012	61.9%	68.7%
Housing units in multi-unit structures, percent, 2008-2012	29.8%	18.0%
Median value of owner-occupied housing units, 2008-2012	\$139,400	\$120,000
Households, 2008-2012	242,944	1,691,716
Persons per household, 2008-2012	2.41	2.49
Per capita money income in past 12 months (2012 dollars), 2008-2012	\$25,623	\$23,210
Median household income, 2008-2012	\$44,111	\$42,610
Persons below poverty level, percent, 2008-2012	18.2%	18.6%
<hr/>		
Business QuickFacts	Louisville/Jefferson	
	County	Kentucky
Total number of firms, 2007	52,778	337,600
Black-owned firms, percent, 2007	8.9%	3.1%
American Indian- and Alaska Native-owned firms, percent, 2007	0.5%	0.3%
Asian-owned firms, percent, 2007	2.7%	1.6%
Native Hawaiian and Other Pacific Islander-owned firms, percent, 2007	0.1%	0.0%
Hispanic-owned firms, percent, 2007	2.0%	1.1%
Women-owned firms, percent, 2007	27.7%	25.6%
<hr/>		
Manufacturers shipments, 2007 (\$1000)	24,118,611	119,105,421

Merchant wholesaler sales, 2007 (\$1000)	10,857,887	74,680,759
Retail sales, 2007 (\$1000)	7,457,373	50,405,925
Retail sales per capita, 2007	\$13,254	\$11,843
Accommodation and food services sales, 2007 (\$1000)	1,257,707	6,300,866

Geography QuickFacts	Louisville/Jefferson County	Kentucky
Land area in square miles, 2010	325.25	39,486.34
Persons per square mile, 2010	1,836.6	109.9
FIPS Code	48006	21
Counties		

(a) Includes persons reporting only one race.

(b) Hispanics may be of any race, so also are included in applicable race categories.

D: Suppressed to avoid disclosure of confidential information

F: Fewer than 25 firms

FN: Footnote on this item for this area in place of data

NA: Not available

S: Suppressed; does not meet publication standards

X: Not applicable

Z: Value greater than zero but less than half unit of measure shown

Source U.S. Census Bureau: State and County QuickFacts. Data derived from Population Estimates, American Community Survey, Census of Population and Housing, County Business Patterns, Economic Census, Survey of Business Owners, Building Permits, Census of Governments

Last Revised: Thursday, 27-Mar-2014 09:55:16 EDT

USPS Demographics for Zip Codes 40203, 40204, & 40217

The following numbers have been acquired using the United States Postal Service's mail route demographics. Note, some routes travel outside of some of the neighborhood boundaries, however these numbers are reflective of the entire neighborhoods represented.

German-Paristown Neighborhood Demographics - 40204

Zip Code Route #	Resident	Business	Total
40204-C001	447	78	555
40204-C013	552	53	605
40204-C025	679	15	694
40204-C026	561	30	591
40204-C032	331	3	334
40204-C044	673	34	707
TOTAL	3243	213	3489*

Schnitzelburg Neighborhood Demographics - 40217

Zip Code Route #	Resident	Business	Total
40217-C039	557	24	581
40217-C041	604	38	642
40217-C044	168	0	168
40217-C046	676	59	735
40217-C049	504	68	572
40217-C051	597	5	602
40217-C053	658	38	658
TOTAL	3764	232	3958*

USPS Demographics for Zip Codes 40203, 40204, & 40217

Shelby Park Neighborhood Demographics - 40203

Zip Code Route #	Resident	Business	Total
40203-C011	579	81	660
40203-C039	631	42	673
40203-C045	976	35	1011
TOTAL	2186	158	2344

Funding Sources:

- 1) #1 Winner²⁰¹³ - 2,018.⁰⁰
 - 2) Membership Dues - 1,400.⁰⁰
 - 3) Yard Sale - 250.⁰⁰
 - 4) Golf Scramble - 7,085.⁰⁰
- 10,753.⁰⁰

* Addition to "OTHER" List on Budget:

Goss Avenue Boards Volunteer - 200 cost - 2,000 = 2,200
Total

So new total events; other figures:

$$16,660 + 200 = 16,860 - \text{volunteer}$$

$$10,997 + 2000 = \underline{12,997} - \text{cost}$$

$$29,857.⁰⁰$$

Incoming Funds for #1 Dinner	Ads	320.00
	Door Prize Raffle	187.00
	50/50	101.00
	Dinners	1410.00
TOTAL IN		2018.00

Movie Night	Jennifer Chappell	Jennifer Chappell	15 get movie, equip. set up	\$150.00	\$1,300.00	\$1,610.00
		Others	10 set up, tear down	\$100.00		
		Mike Morris	6 weed, mow, blow	\$60.00		
Dog Walk	Judie Greiner	Judie Greiner	10 Organize	\$100.00	\$100.00	\$260.00
		Mike Morris	6 weed, mow, blow	\$60.00		
#1 Dinner	Gary Allen	Gary Allen	20 get prizes,	\$200.00	\$2,500.00	\$2,930.00
		Others	20 sell ads, order food, bar	\$200.00		
		Mike Morris	3 weed, mow, blow	\$30.00		
Christmas Tree Decorating	Julieanne Thomas	Julieanne Thomas	5 Obtain tree, decorate	\$50.00	\$100.00	\$260.00
		Others	5 Decorate	\$50.00		
		Mike Morris	6 weed, mow, blow	\$60.00		
GoGreenGermantown	Susan Brunton	Susan Brunton	200 Plant, Shop, Water	\$2,000.00	\$2,000.00	\$8,580.00
		Others	200 plant, weed	\$2,000.00		
		Mike Morris	258 weed, mow, blow	\$2,580.00		
Estimated Totals						

Event	Organizer	Volunteers	Hours Donated	Description of Time	Hours x \$10.00/hr	Costs	Total to Budget
History Walks (2 per Year)	Steve Cambron	Steve Cambron	12		\$120.00	\$200.00	
		Lisa Pisterman	12		\$120.00		
		Mike Morris	11	weeding, cleaning route	\$110.00		
Easter Egg Hunt	Dianna Morris	Dianna Morris	12		\$120.00	\$200.00	
		Susan Brunton	10		\$100.00		
		Others	10		\$100.00		
		Mike Morris	6	trash pick up	\$60.00		
PlayDate in the Park	Susan Brunton	Susan Brunton	12		\$120.00	\$200.00	
		Dianna Morris	4		\$40.00		
		Others	6		\$60.00		
		Mike Morris	6	trash pick up	\$60.00		
Pot Luck	Susan Brunton	Susan Brunton	10	set up	\$100.00	\$200.00	
		Others	10	tear down	\$100.00		
		Mike Morris	3	trash pick up	\$30.00		
Dainty	Gary Allen/Mike Morris	Gary Allen	20	Set Up, emcee, manage	\$200.00	\$1,300.00	
		Mike Morris	5	line judge	\$50.00		
		Mike Morris	9	weed, mow, blow	\$90.00		
Back to School Bash	Dianna Morris	Dianna Morris	12		\$120.00	\$100.00	
		Others	10		\$100.00		
		Mike Morris	6	trash pick up	\$60.00		
Yard Sale	Susan Brunton	Susan Brunton	12	sell spots, direct vendors	\$120.00	\$50.00	
		Others	10	man booth,	\$100.00		
		Mike Morris	6	weed, mow, blow	\$60.00		

Actual

History Walk Expenses: 10.44

Bottled Water 10.44

Easter Egg Hunt: 207.96

Eggs 35.62

Candy 48.27

Decorations 124.07

Play Date in the Park: 98.64

Balloons 3.18

Snacks & Refreshments 13.77

Tablecloths, Purell, etc. 7.49

Toys, Chalk, Balls, etc. 12.72

Mini Flags 44.52

Pot Luck: 84.98

Main Course 84.98

Dainty Contest: 944.25

Security 125.00

Band 550.00

Permit 40.00

Paint 9.51

Port a Potties 175.00

Printing Dainty Cards 44.74

Back to School Bash: 0.00

Yard Sale: 59.05

C-J Ad 38.00

Poster Board, Snacks 21.05

1,405.32

Movie Night: 1296.89

Permit	212.50
Screen	265.00
Insurance	162.32
Port a Potties	170.00
Movie	313.74
Prizes	44.41
Decorations	128.92

Dog Walk: 2.38

Dog Biscuits	2.38
--------------	------

#1 Citizen Dinner: 2,256.61

Food	1499.37
Printing Programs	240.83
Decorations	111.11
Jacket Monogram	5.30
Hall Rental	250.00
Hall Cleanup	150.00

Light Up the Burg: 299.29

Pole Decorations	75.13
Tree Decorations	77.93
Santa Suit	74.19
Candy	63.04
Cocoa	9.00

GoGreen Germantown: 2096.16

Mulch & Potting Soil	239.56
Trees	917.85
Bushes & Shrubs	271.33
Tools, Bags, Weed Control, etc.	267.27
Flowers	161.13
Containers	239.02

5951.33

1405.32

7,356.65

Three Points Beautification

Project Proposal

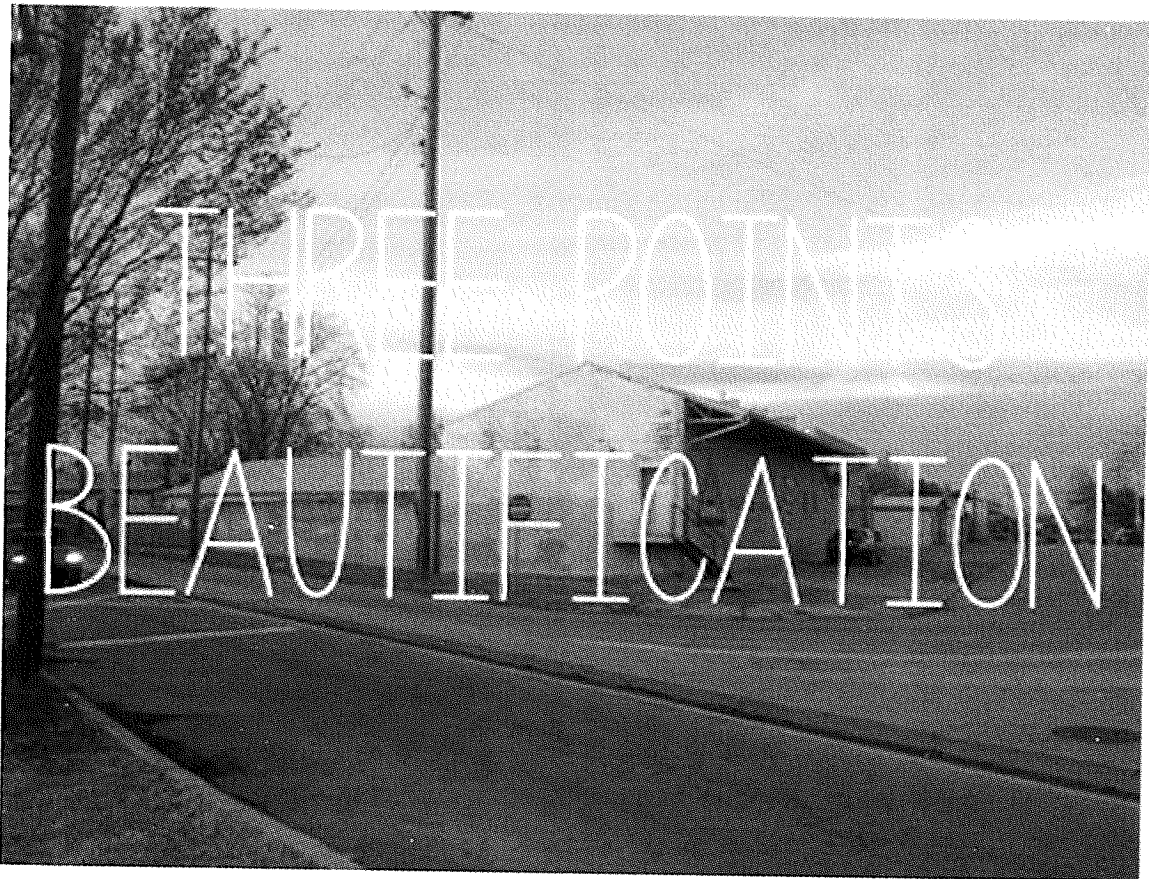

Executive Summary

Objective

Complete a beautification project at the intersection of Goss Avenue and Logan Street that will enhance the revitalization projects already underway in the community and to improve its functionality to residents in the area. This intersection is where three neighborhoods meet: German-Paristown, Schnitzelburg, and Shelby Park. All neighborhood organizations (German-Paristown Neighborhood Association, Schnitzelburg Area Community Council, and Shelby Park Neighborhood Association) have been contacted and fully support the project. A major project underway in the Schnitzelburg neighborhood that will directly impact this project in terms of increasing both foot and automotive traffic is the the Germantown Mill Lofts project that will add over 180 new residents to this area. Investment in the Three Points Beautification Project is an investment in the community.

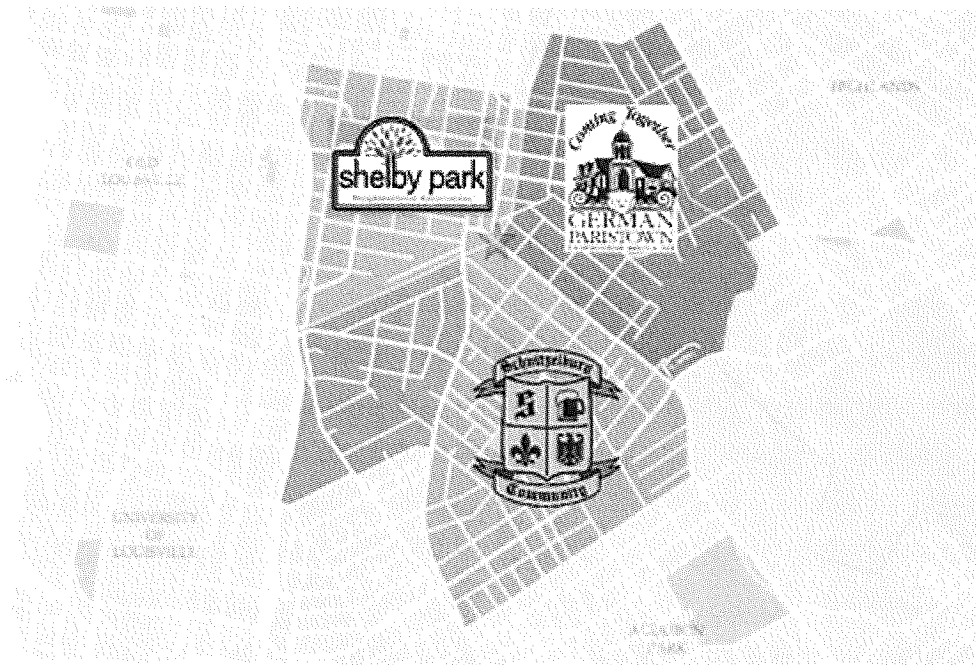

Goals

- Beautify the blighted area and make it a representation of the culturally diverse and artist community;
- Paint a mural that incorporates the idea of the “Three Points” - communities coming together;
- Give residents pride in their community and show “investment” is made for their future and well-being;
- Create signage that allows visitors to the area to understand where they are, what neighborhoods surround them, and help them navigate between the neighborhoods;
- Become a “hotspot” for visitors that will be beneficial to small, local businesses and Louisville as a whole;
- Add greenery that will serve as both aesthetically pleasing and functional and increase Louisville’s tree canopy;
- Improve walkability and safety for pedestrians;
- Partner with organizations in the community that will increase the communities involvement.

Solution

- Abell Elevator has granted permission for the side of their building facing Logan Street to be painted with a mural. The building extends to a long concrete wall that will also be included in the mural. Henry Cunningham and Chris Chappell (no relation to Project Manager, Jennifer Chappell) have signed on as the artists undertaking the mural. They are currently collaborating on a design that will be modern, bold, and reflective of the community. So far, the concept has been described as “portraits in black and white scales with colorful graphic elements that will create transparent effects and add depth to the wall.” A smaller “mural” will be painted on the side of the blue storage shed across from Abell’s main building. It will have arrows pointing in the direction of various neighborhoods and have a simple map to show visitors which neighborhood is where (Each neighborhood will be represented by a different color that is reflective of their neighborhood crest/logo. German-Paristown = purple; Schnitzelburg = yellow; Shelby Park = green). With each of the neighborhoods embracing branding, this will act as a facilitator to increasing visitor traffic in each neighborhood that will hopefully increase business for local shops.



- Paint for the project will be supplied by Dages Paint Company (1140 East Oak Street).
- The German-Paristown Neighborhood Association, Shelby Park Neighborhood Association, and the Schnitzelburg Area Community Council have all been very supportive of the project and are lending help in any way possible. Letters of approval from each of the three aforementioned organizations have been received and are attached to this proposal.

- Extensive landscaping will be done to the area courtesy of Luv-It Landscaping. Luv-It landscaping will clear and edge the existing area before adding trees, shrubs, and decorative materials. Trees added in the project will add to Louisville's tree canopy and will help absorb some of the noise from passing trains on the nearby railroad tracks. Low lying shrubs will be placed in front of the completed mural. Their work will also include a rain garden near the Abell Elevator building that will aid in rain catchment for the currently impermeable surface that retains a substantial amount of water. The possibility of adding something "green" to the median remains open.

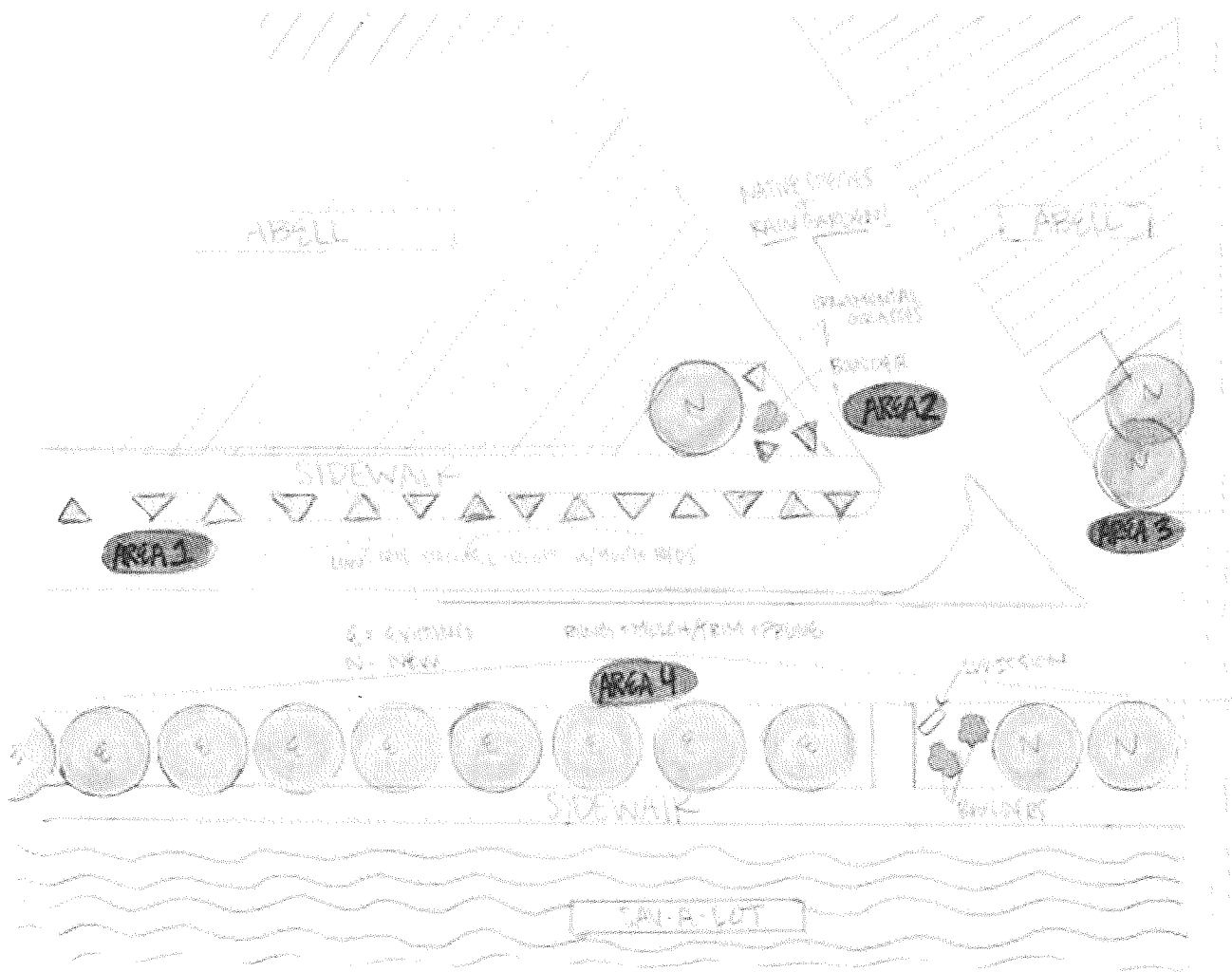

- Sidewalks will be repaired and repaved for pedestrians. Public Works has provided Jim King's office with an estimate to complete the job. Once it goes through the appropriations process it will be in place to be completed by the contractor associated with Jim King's office. It is still too early in the process to have an estimate on when it will be completed. Current sidewalk conditions:

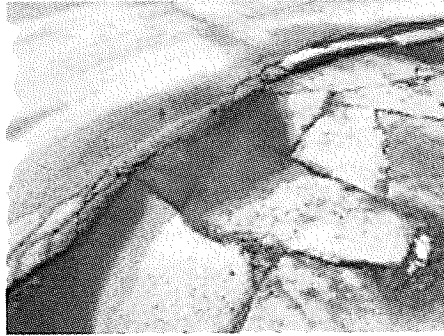

- Partnerships with local businesses and organizations are underway that will give the public a chance to interact with the environment after the project is completed:
 - Save-A-Lot grocery store (1311 South Shelby Street) is another partnership in the works that, if approved by their corporate office, will provide a bench and trash can near the opening of their parking lot on Logan Street. The street furniture company, All Recreation, has generated multiple quotes for different bench and trash receptacle packages which have been forwarded to Tara Jasper at the Save-a-lot corporate offices c/o Buehler's Food Inc.
 - If agreement for donation has been reached, M3 Solutions will construct the proper concrete anchor/pad that will secure the bench and receptacle to the site.
 - Feed the Dirt, a local composting start-up, will be involved to promote "green," or sustainability, education. One of the possible incorporations would be growing an edible plant grown from their compost (possibly a climbing loofa plant that will be grown along the Save-a-lot fence). Another incorporation is dependent on the degree that Save-a-lot will donate. Save-a-lot has received an estimate for a tri-compartment receptacle that will have designated bins for trash, recycling, and organic material. This tri-compartment receptacle is considerably more expensive than the regular 32 gallon receptacle, but this would enable Feed the Dirt to provide signage that explains what organic material is and how it can be used to create compost.

Funding

As a civic centered project, we are looking to acquire funds from the community through Neighborhood Development Funds (NDF) and a fundraising campaign.

The Schnitzelburg Area Community Council will be the organization channelling funds from the source to the project. They will use their bank account at PNC Bank to hold funds until it is appropriate to disperse them. All transactions will be recorded and receipts kept.

Jim King, Metro Council President and District 10 Councilman, has agreed to donate \$4,000.00 to the project, as of February 2014. An NDF form is being completed in order to gain these funds. The project lies on the boundary of District 10.

David Tandy, District 4 Councilman, was contacted to solicit funds and potentially match Councilman King's donation. The entirety of the project lies in District 4. David Tandy has agreed to donate \$2,500.00 to the project, as of May 2014. These funds will be added onto the NDF form that is being completed for District 10.

The completed NDF form will be filed by June 2nd at the Clerk's office for the Appropriations Committee to review it on June 11th. Because the requested amount is over \$5,000, it will go to the full Council on June 19th for approval. If the grant is approved, a grant agreement will be issued that will need to be completed and returned. Once returned, it will take about 4 weeks to get the check, which puts the check being "in hand" in mid to late July.

Since Neighborhood Development Funds may not cover the entire cost of the project, the project has been green-lighted to be featured on a website called Neighbor.ly that will be used to solicit funds from the general public during the month of June. Neighbor.ly's concept is similar to Indi Go-Go or Kickstarter in that anyone can go online and donate any amount to a project or idea they like. The difference lies in that projects featured on Neighbor.ly must be civic-minded projects that enhance a community. The projects must be backed by a civic organization, a neighborhood group, or a non-profit organization. If the total amount is not raised by the end of the Neighbor.ly campaign, we will still have access to whatever funds we were able to raise.

Levels of perks have been added to the Neighbor.ly project, so that people who donate will receive something in return. Perks include receiving a digital thank you (\$10), having your name put onto the wall (\$25), receiving a t-shirt (\$50), sponsoring a tree (\$100), and original art from the artists (\$500+).

It is a priority for the project to engage the community and make the whole feel invested in the project.

Budget

The following is a rough budget for the project. Prices for items such as paint, primer, paint supplies, bucket truck rental and other miscellaneous expenses will not be finalized until a later time. Attached to the proposal are most invoices for the project costs that are identified below.

Description	Quantity	Unit Price	Cost
Artist Fees	2	\$1,500.00	\$3,000.00
Paint Primer*	4	\$140.00	\$560.00
Paint*	20	\$100.00	\$2,000.00
Paint Supplies*	1	\$500.00	\$500.00
Bucket Truck Rental*	1	\$100.00	\$100.00
Landscaping	1	\$2,000.00	\$2,000.00
Bench & Trash Receptacle - donated by Save-a-Lot**	1	\$4,846.90	\$4,846.90
Feed the Dirt Installation	1		
M-3 Concrete Work*	1	\$500.00	\$500.00
Urban Composition Conceptual Drawings	1	\$150.00	\$150.00
Miscellaneous Administrative Costs*	1	\$100.00	\$100.00
Sidewalk Repairs - cost covered by Jim King/Public Works	1	\$0.00	\$0.00
		Subtotal	\$13,756.90
		Tax 0.00%	\$0.00
		Total	\$13,756.90

*This number is an estimate and does not reflect the actual price.

**This cost will be donated by Save-a-Lot Grocery Store

Schedule

Date	Task
December	Project started. Permission granted from Abell Elevator to put mural on the side of their building and small building across from main building.
January	Artists contacted and "hired."
February	Councilman King agrees to fund \$4,000.00 for project. Meet with Luv-It Landscaping to review site; received quote. Project is "green-lighted" by Neighbor.ly.
March	Artists visit site and begin conceptual materials for mural. Jim King's office received work from Public Works that sidewalks are on agenda to be paved.
April	Meet with All Recreation at site to discuss bench and trash receptacle options; received two quotes. Material sent to Save-a-Lot corporate store for approval of donation. Received letters of support from all three neighborhood organizations.
May	Councilman Tandy agrees to fund \$2,500.00 for project. Complete and send in NDF applications for 6/2/14 review (attend NDF seminar 5/14/14). Meet with Dages Paint. Proposal sent out to all parties involved in project and included on attached contact list.
June	Neighbor.ly site launched. Bench and trash can need to ordered. Concrete pad/anchors for bench placed?
July	Paint and paint supplies received from Dages. Priming of the mural will occur in mid to late July with full mural being painted during week of July 28th through August 2nd. Light landscaping preparation will occur before any paint goes on the wall.
August	Landscaping will be completed after mural has been completed.
September	PROJECT COMPLETE!

Contact Information

Project Manager

Any questions, comments, concerns or otherwise should be directed to the Project Manager who has worked on this project from its infancy through development of present day:

Jennifer Chappell
1036 Ash Street
Louisville, Kentucky 40217
T 502.641.7534
F 502.568.6234
jnnfr.r.chppl@gmail.com
schnitzelburg.blogspot.com

The Schnitzelburg Area Community Council can be reached at:

P.O. Box 17306
Louisville, Kentucky 40217
schnitzelburg@yahoo.com

Three Points Beautification Project Contacts

(Alphabetical Order)

Abell Elevator Company
1256 Logan Street
Louisville, Kentucky 40204
Contact: David Lloyd
Email: David@abellelevator.com
O: 502.634.3350 ext. 445
C: 502.639.3321

All Recreation
20609 Gordon Park Square, Suite 190
Ashburn, Virginia 20147
Contact: Darrell Pryor
Email: Darrell@allrec.com
O: 888.419.0001
C: 859.779.0522

Councilman David Tandy
City Hall
601 West Jefferson Street
Louisville, Kentucky 40202
Contact: Keidra King
Email: keidra.king@louisvilleky.gov
O: 502.574.1192

Councilman Jim King
City Hall
601 West Jefferson Street
Louisville, Kentucky 40202
Contact: Carrie Peers
Email: carrie.peers@louisvilleky.gov
O: 502.574.1192

Dages Paint
1140 East Oak Street
Louisville, Kentucky 40204
Contact: David Nutt
Email: david_dagespaint@bellsouth.net
O: 502.635.2666

Feed the Dirt
Meriwether Avenue
Louisville, Kentucky 40217
Contact: Joshua Orr
josh@feedthedirt.org
C: 502.619.3449

GPNA
1094 East Kentucky Street
Louisville, Kentucky 40204
Contact: Steve Magre
Email: stevemagre.m39@gmail.com
C: 502.855.0223

Luv-It Landscaping
P.O. Box 17192
Louisville, Kentucky 40207
Contact: James Weiter
Email: missluvit@twc.com
O: 502.635.1685

M-3 Solutions LLC
P.O. Box 34451
Louisville, Kentucky 40232
Contact: Jordan Mitchell
Email: Jordan@m3-llc.com
O: 866.960.9291

SACC
P.O. Box 17306
Louisville, Kentucky 40217
Contact: Mike Morris
Email: mike@mikemorrislaw.com
C: 502.439.7558

Save-a-Lot/Buehler's Inc.
307 Newton Street
Jasper, Indiana 47546
Contact: Tara Jasper
Email: tjasper@buehlerinc.com
O: 812.634.7029 ext. 101
Rick = Manager @ Shelby Street Store

SPNA
600 East Oak Street
Louisville, Kentucky 40203
Contact: Chip Rogalinski
Email: Charles.rogalinski@ky.gov
C: 502.417.5336





Date 4/7/14

To whom it may concern:

GPNA is in strong support of Jennifer Chappell's concept for the Three Points Beautification Project. We believe the area chosen for the mural and landscape upgrades is most fitting and, when in place, will give explanation of how the three historic neighborhoods actually join together at a given point.

German-Paristown Neighborhood Association
1094 East Kentucky Street
Louisville, Kentucky 40204

An interesting aspect of the discussion that has taken place around this project is the success those talks have generated in an added way. The leaders of SACC, GPNA and SPNA have agreed to work in a collegial manner on this and on broader area issues. Each of us ask you both as proven city and neighborhood leaders to consider how well this overall beautification project and the major new mural tie to the improvements happening in the area immediately north and east of the project area. Consider the city's recent votes that have allowed the Old Antique Mall on Goss to move forward to see it converted to a major new housing development with numerous other additions that once in place will allow neighborhood access. We are all aware of the city's role in right now moving forward to develop an exciting new plan that calls for the city and neighbors to partner in agreeing upon and then overseeing major changes and new upgrades along the CSX Railway Corridor. This corridor runs adjacent to the project area and the historic dual tracks run through the 3 neighborhoods.

Finally there is the Goss Avenue Beautification Project that is in its early phase of implementation. It is a cause that is coordinated via Councilman King, GPNA and SACC and it too is happening now. So the best timing that connects best with all this activity is to move on Jennifer's project now.

GPNA asks the councilmen to step forward to help make this important concept a reality. We want most for the drawing to be taken from paper only and become completed.

Thanks for your consideration.

Sincerely yours,

Steve Magre

Volunteer Administrator

German-Paristown Neighborhood Association



SCHNITZELBURG AREA COMMUNITY COUNCIL

P.O. Box 17306

Louisville, Kentucky 40217

April 7, 2014

Metro Councilman
City Hall
601 West Jefferson Street
Louisville, Kentucky 40202

Dear Councilman,

The Schnitzelburg Area Community Council would like our support of the Three Points Beautification project to be known. We believe the project including a mural, new landscaping, and infrastructure improvements will greatly improve the aesthetics of the intersection on Goss Avenue and Logan Streets and enhance the neighborhoods that respectively meet at the intersection. We wholly support the emphasis this project puts on bringing three historic neighborhoods together: German-Paristown, Shelby Park and Schnitzelburg.

As this intersection is a "gateway" into Schnitzelburg, we feel the project will be instrumental into welcoming people into the neighborhood and creating awareness of our great neighborhood.

Furthermore, we believe this project will complement the Goss Avenue Beautification Project currently underway and the massive renovation of the former Goss Antique Mall into the Germantown Mill Lofts. As developers invest in the community, we would like to see surrounding areas be invested in as well. With the positive momentum from projects such as this, we look forward to an enriched community.

As the SACC offers support of the Three Points Beautification, we hope you will be able to support the project as well. We look forward to the final product of this project and the positive contributions it will make to the community.

Sincerely yours,

Mike Morris
SACC President



Shelby Park Neighborhood Association

600 E Oak Street
Louisville, KY 40203

April 23, 2014

Louisville Metro Council
Metro Council offices
Neighborhood Development Fund Administrator

Subject: Three Points Beautification Project

Dear Administrator,

On behalf of the Shelby Park Neighborhood Association, I am writing to support the funding of the project that Jennifer Chappell has initiated. The Three Points beautification project is physically located within the boundaries of our incorporated neighborhood association. We believe that funding from the Neighborhood Development Fund is an appropriate use of Metro dollars to improve the connection between the Schnitzelburg, German-Paristown and Shelby Park neighborhoods.

This project coincides with our current effort to improve entrances to our neighborhood as a means to drive interest in improving our shotgun housing stock.

Thank you for your assistance. I trust we can expedite this project so as to encourage others to work within our neighborhood.

Best,

Chip Rogalinski, President
Shelby Park Neighborhood Association

Chris Chappell

1913 Harvard Drive
Louisville, Kentucky 40205
Phone: 502.827.9731
E-Mail: clchappell@gmail.com
Web: clchappell.com

Invoice

Bill To:

Schnitzelburg Area Community Council
P.O. Box 17603
Louisville, Kentucky 40217

Date	Project Title	Project Manager	Terms	Tax ID
4/14/2014	Three Points Mural	Jennifer Chappell	Payment Upon Completion	n/a

Item	Description	Total
Mural Design	Design for the wall of the Abell Elevator Company wall	\$500.00
Labor	Painting the design on the entirety of the wall. Payment based on completion rather than quantitative days worked. Work to be completed between July 28 th and August 3 rd .	\$1,000.00
	Note: Paint, paint supplies, and other materials to be provided separately.	

Subtotal:	\$1,500.00
Tax:	0%
Balance Due:	\$1,500.00

Henry Cunningham

2109 Edge Hill Road
 Louisville, Kentucky 40205
 Phone: 502.377.7850
 E-Mail: henry.cunningham13@my.stjohns.edu

Invoice

Bill To:

Schnitzelburg Area Community Council
 P.O. Box 17603
 Louisville, Kentucky 40217

Date	Project Title	Project Manager	Terms	Tax ID
4/14/2014	Three Points Mural	Jennifer Chappell	Payment Upon Completion	n/a

Item	Description	Total
Mural Design	Design for the wall of the Abell Elevator Company wall	\$500.00
Labor	Painting the design on the entirety of the wall. Payment based on completion rather than quantitative days worked. Work to be completed between July 28 th and August 3 rd .	\$1,000.00
Note: Paint, paint supplies, and other materials to be provided separately.		

Subtotal:	\$1,500.00
Tax:	0%
Balance Due:	\$1,500.00



Luv-it Landscaping

P.O. Box 17192
Louisville KY 40217
502-635-1685

Estimate

Number: **E8472**

Date: **February 17, 2014**

We Do Not Bill Until you say you "Luv-It"

Jennifer Chappel
SACC
RR track at Goss Ave

Ship To:

Jennifer Chappel
SACC
RR track at Goss Ave

Home Phone

641-7534

Work Phone

Fax

Description

Amount

Landscape (see attached)

3 small Redbuds

6 Ornamental grasses

Junipers, grasses, Knockouts

iris, stellas, Liriope

ring and mulch trees

Prune and Trim

Boulders

edge

mulch hardwood

1 sign

Total includes all materials and Labor

2,000.00

Total

\$2,000.00

All material is guaranteed to be as specified and the above work to be performed in accordance with the drawings and specifications submitted for above work and completed in a substantial workmanlike manner for the sum of \$ _____. Payment to be made upon the completion of job. We guarantee to replace all nursery stock planted by us (one time) at no charge for cost of plant material; however there will be an installation charge for preparation, labor & installing, provided this account is paid when due. Purchaser obligates himself to give reasonable care to material planted such as watering, cultivating, spraying and protection from weather and animals. Luv-it Landscaping is not responsible for any underlying obstructions. It is the purchaser's obligation to locate all underground lines, wires, pipes, etc. that are subject to damage during landscape construction. No guarantee can be given on seeding, strapping, sodding, annual plants and ground covers. Any alteration or deviation from above specifications involving extra costs, will be executed only upon written orders, and will become an extra charge over and above the estimate. All agreements contingent upon weather, accidents or delays beyond our control. Owner to carry fire, tornado and other necessary insurance upon above work.

Respectfully submitted _____

Note: This proposal may be withdrawn by us if not accepted within _____ days.

Acceptance of Proposal - The above prices, specifications and conditions are satisfactory and are hereby accepted. You are authorized to do the work as specified. Payment will be made as outlined above.

Date of Acceptance: _____

Signature: _____

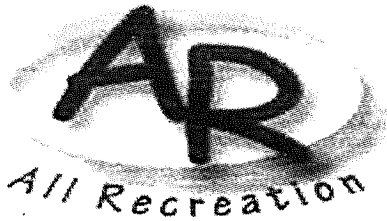

All Recreation of Virginia, Inc.
 20609 Gordon Park Square
 Suite 190
 Ashburn, VA 20147
Darrell's Cell: 859-779-0522
Main Office Ph: 888-419-0001
Fax: 703-589-1493

PROPOSAL

Quote # ARVQ16081

Date 04/22/14

Sales Rep. Darrell Pryor

Customer's PO No:

Shipping Method: Common Carrier

Terms

80% deposit with the order, the balance is due when product is received

Bill To:

Schnitzelburg 3 Points
 Beautification Project
 PO Box 17306

Louisville KY 40217

Attn: Jennifer Chappell

Phone: 502-641-7534

Fax:

Email: jnnfr.r.chppll@gmail.com

Ship To:

Schnitzelburg 3 Points
 Beautification Project
 c/o Save A Lot

1311 S. Shelby St.

Louisville KY 40217

Attn: Jennifer Chappell

Phone: 502-641-7534

Fax:

Email: jnnfr.r.chppll@gmail.com

Qty	Item No.	Description	Unit Price	Ext. Price
1	DuMor 93-60-Q30	6' CAST BENCH, STL SEAT, 2 ARMS FOR 4X6 PLAQUE	\$1,065.00	\$1,065.00
1	DuMor PLAQUE-021358	4" X 6" ZINC ETCHED PLAQUE INSTALLED	\$330.00	\$330.00
1	DuMor 84-32-CVR-30-FTO	32-GALLON ALL-STEEL RECEPTACLE w/ 25-3/8" DIA STL FLAT CVR, 10" HOLE	\$765.00	\$765.00
	COLORS	Bench: Receptacle w/ Flat Cover:		
			SubTotal	\$2,160.00
			Sales Tax	\$129.60
			Freight	\$289.00
			Total	\$2,578.60

WE PROPOSE hereby to furnish complete in accordance with the above specifications. Accounts over 10 days old are subject to 1-1/2% monthly charge. NOTE: This proposal may be withdrawn by All Recreation of Virginia, Inc. if not accepted with ten (10) days. Customer is responsible to locate and mark all private utilities. All Recreation of Virginia, Inc. and it's installers will not be held responsible for any damage to any private utilities damaged in the installation process which were not located and marked by the customer.

 Authorized All Recreation of VA, Inc. Signature

ACCEPTANCE OF PROPOSAL: The above prices, specifications and conditions are satisfactory and are hereby accepted:

 Authorized Customer Signature

 Date

 Tax Exempt Number

Make checks payable to All Recreation of Virginia, Inc. Please put proposal/ invoice number(s) on check. Credit Card processing fees are additional: 2% for Visa and Master Card. * Processing fee to be applied only for charges \$1000.00 and above.

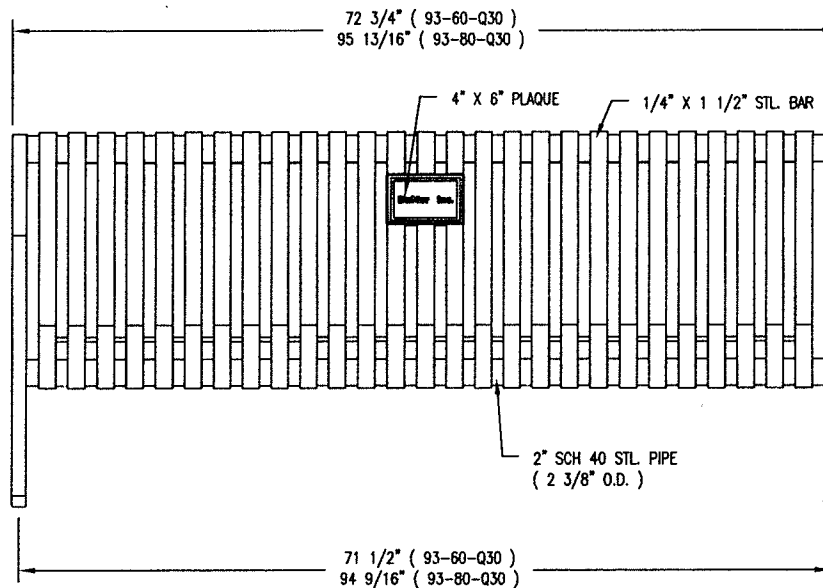
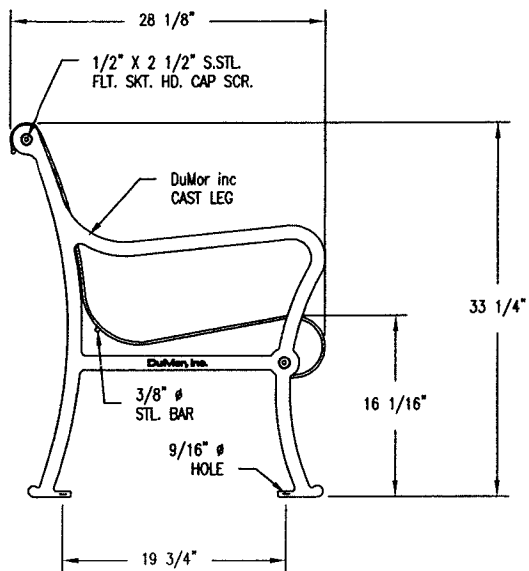

LENGTH OPTIONS

- 6' BENCH
- 8' BENCH

NOTES:

- 1.) ALL STL. MEMBERS COATED W/ ZINC RICH EPOXY THEN FINISHED W/ POLYESTER POWDER COATING.
- 2.) 1/2" X 3 3/4" EXPANSION ANCHOR BOLTS PROVIDED
- 3.) BENCH IS SHIPPED UNASSEMBLED.

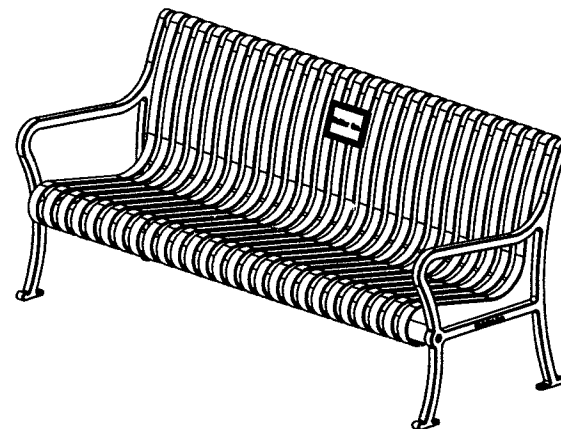

DuMor, inc.
 P.O. Box 142 Mifflintown, PA 17059-0142

DATE DRAWN : 9/21/06
 DRAWN BY : AWH
 DATE REV. : 08/04/09
 REV. BY : ESS

TITLE		BENCH FOR 4" X 6" PLAQUE	
REVISION	B	DRAWING NUMBER	93 SERIES Q30 SH1

NOTES:

- 1.) DURING ASSEMBLY DO NOT COMPLETELY TIGHTEN HARDWARE.
- 2.) THE ACTUAL PARTS WILL NOT BE NUMBERED, NUMBERS ONLY APPLY TO DRAWING.
- 3.) UPON COMPLETION OF BENCH ASSEMBLY, SQUARE ALL COMPONENTS THEN TIGHTEN ALL HARDWARE.

REMOVE 1/2" X 2" HEX HEAD BOLT AND SHIPPING BRACE AND DISCARD

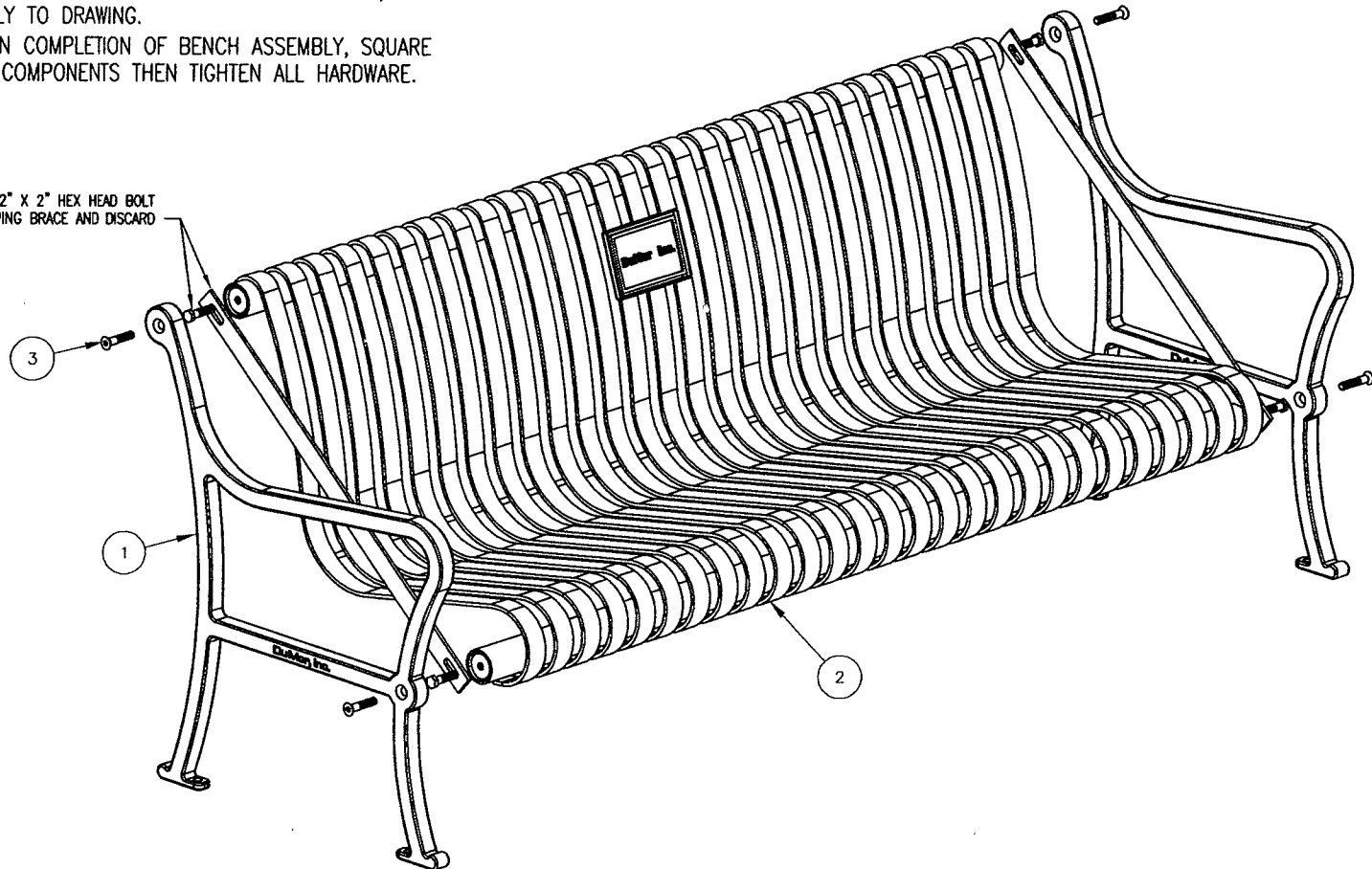

KITS REQUIRED

ITEM	QTY	PART NO	DESCRIPTION
7	1	K-ANCO860-4	1/2" X 3 3/4" SS ANCHOR KIT (4PC)
8	1	K-FC0840-4	1/2" CAP HARDWARE KIT (4 PCS)

ITEM	QTY	PART NO	DESCRIPTION
1	2	0-93-00-02	CAST IRON BENCH SUPPORT
2	1	0-93-60-Q30	6' STL SEAT ASSEMBLY FOR 4X6 PLQ
3	4	1-12-065	1/2" X 2 1/2" FLT SKT HD CAP SCR

DuMor, inc.
P.O. Box 142 Mifflintown, PA 17059-0142

TOOLS REQ'D
3/4" WRENCH
5/16" ALLEN WRENCH
DRILL & 1/2" MASONRY DRILL BIT

DATE DRAWN : 08/04/09
DRAWN BY : ESS
DATE REV. :
REV. BY :

TITLE	INSTALLATION		
REVISION	A	DRAWING NUMBER	93 SERIES Q30 SH2



All Recreation of Virginia, Inc.
 20609 Gordon Park Square
 Suite 190
 Ashburn, VA 20147
Darrell's Cell: 859-779-0522
Main Office Ph: 888-419-0001
Fax: 703-589-1493

PROPOSAL

Quote # ARVQ16082

Date 04/22/14

Sales Rep. Darrell Pryor

Customer's PO No:

Shipping Method: Common Carrier

Terms

80% deposit with the order, the balance is due when product is received

Bill To:

Schnitzelburg 3 Points
 Beautification Project
 PO Box 17306

Louisville KY 40217
 Attn: Jennifer Chappell
 Phone: 502-641-7534
 Fax:
 Email: jnnfr.r.chppll@gmail.com

Ship To:

Schnitzelburg 3 Points
 Beautification Project
 c/o Save A Lot
 1311 S. Shelby St.

Louisville KY 40217
 Attn: Jennifer Chappell
 Phone: 502-641-7534
 Fax:
 Email: jnnfr.r.chppll@gmail.com

Qty	Item No.	Description	Unit Price	Ext. Price
1 DuMor	93-60-Q30	6' CAST BENCH, STL SEAT, 2 ARMS FOR 4X6 PLAQUE	\$1,065.00	\$1,065.00
1 DuMor	PLAQUE-021358	4" X 6" ZINC ETCHED PLAQUE INSTALLED	\$330.00	\$330.00
1 DuMor	435-72-0001	72 GAL RECYCLING RECEPT, (Newspaper, Trash, & Bottles/Cans) w/ (1) SIDE OPENING END COVER W/ 5X10 TRASH OPENING (# 0-435-EC-06) & (1) SIDE OPENING MID COVER W/ 5X11 3/8 TRASH OPENINGS (# 0-435-MC-07)	\$2,820.00	\$2,820.00

COLORS

Bench:

Receptacle:

Bottle/Cans Recycle Cover:

Trash Recycle Cover:

Newspaper Recycle Cover:



All Recreation of Virginia, Inc.
 20609 Gordon Park Square
 Suite 190
 Ashburn, VA 20147
Darrell's Cell: 859-779-0522
Main Office Ph: 888-419-0001
Fax: 703-589-1493

PROPOSAL

Quote # ARVQ16082

Date 04/22/14

Sales Rep. Darrell Pryor

Customer's PO No:

Shipping Method: Common Carrier

Terms

80% deposit with the order, the balance is due when product is received

Bill To:

Schnitzelburg 3 Points
 Beautification Project
 PO Box 17306

Louisville KY 40217

Attn: Jennifer Chappell

Phone: 502-641-7534

Fax:

Email: jnnfr.r.chppll@gmail.com

Ship To:

Schnitzelburg 3 Points
 Beautification Project
 c/o Save A Lot
 1311 S. Shelby St.

Louisville KY 40217

Attn: Jennifer Chappell

Phone: 502-641-7534

Fax:

Email: jnnfr.r.chppll@gmail.com

SubTotal	\$4,215.00
Sales Tax	\$252.90
Freight	\$379.00
Total	\$4,846.90

WE PROPOSE hereby to furnish complete in accordance with the above specifications. Accounts over 10 days old are subject to 1-1/2% monthly charge. NOTE: This proposal may be withdrawn by All Recreation of Virginia, Inc. if not accepted with ten (10) days. Customer is responsible to locate and mark all private utilities. All Recreation of Virginia, Inc. and it's installers will not be held responsible for any damage to any private utilities damaged in the installation process which were not located and marked by the customer.

 Authorized All Recreation of VA, Inc. Signature

ACCEPTANCE OF PROPOSAL: The above prices, specifications and conditions are satisfactory and are hereby accepted:

 Authorized Customer Signature

____/____/____
 Date

 Tax Exempt Number

Make checks payable to All Recreation of Virginia, Inc. Please put proposal/ invoice number(s) on check. Credit Card processing fees are additional: 2% for Visa and Master Card. * Processing fee to be applied only for charges \$1000.00 and above.

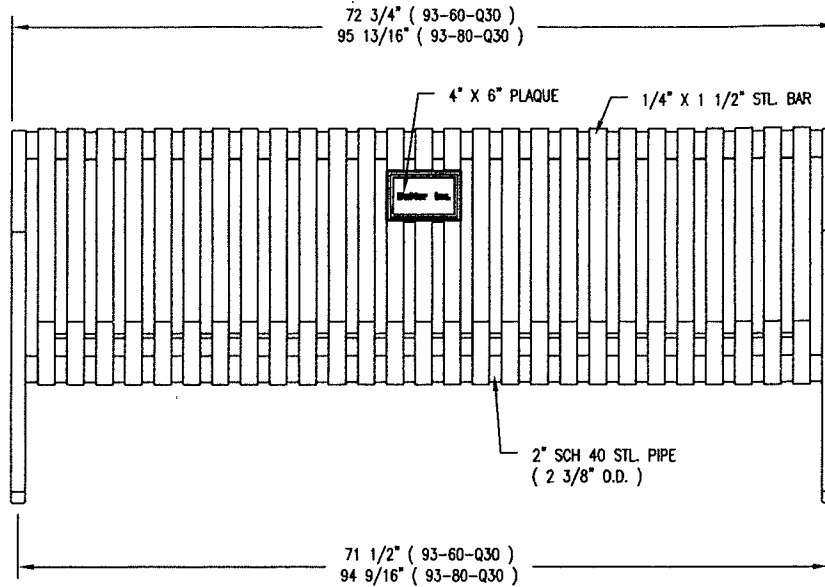
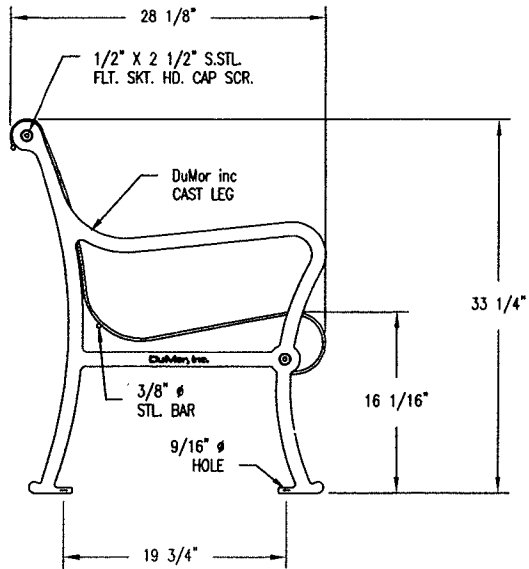

LENGTH OPTIONS

- 6' BENCH
- 8' BENCH

NOTES:

- 1.) ALL STL. MEMBERS COATED W/ ZINC RICH EPOXY THEN FINISHED W/ POLYESTER POWDER COATING.
- 2.) 1/2" X 3 3/4" EXPANSION ANCHOR BOLTS PROVIDED
- 3.) BENCH IS SHIPPED UNASSEMBLED.

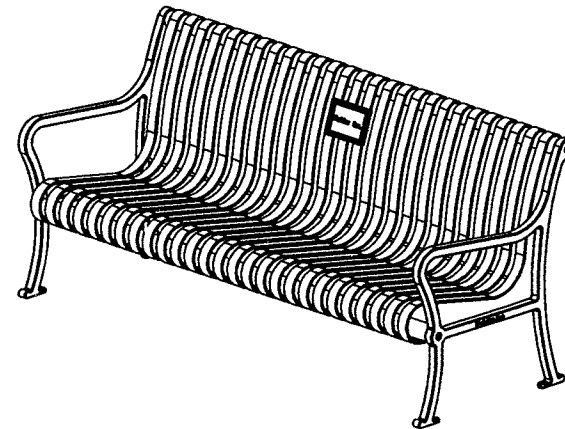

DuMor, inc.

 P.O. Box 142 Mifflintown, PA 17059-0142

DATE DRAWN : 9/21/06
 DRAWN BY : AWH
 DATE REV. : 08/04/09
 REV. BY : ESS

TITLE		BENCH FOR 4" X 6" PLAQUE	
REVISION	B	DRAWING NUMBER	93 SERIES Q30 SH1

NOTES:

- 1.) DURING ASSEMBLY DO NOT COMPLETELY TIGHTEN HARDWARE.
- 2.) THE ACTUAL PARTS WILL NOT BE NUMBERED, NUMBERS ONLY APPLY TO DRAWING.
- 3.) UPON COMPLETION OF BENCH ASSEMBLY, SQUARE ALL COMPONENTS THEN TIGHTEN ALL HARDWARE.

REMOVE 1/2" X 2" HEX HEAD BOLT AND SHIPPING BRACE AND DISCARD

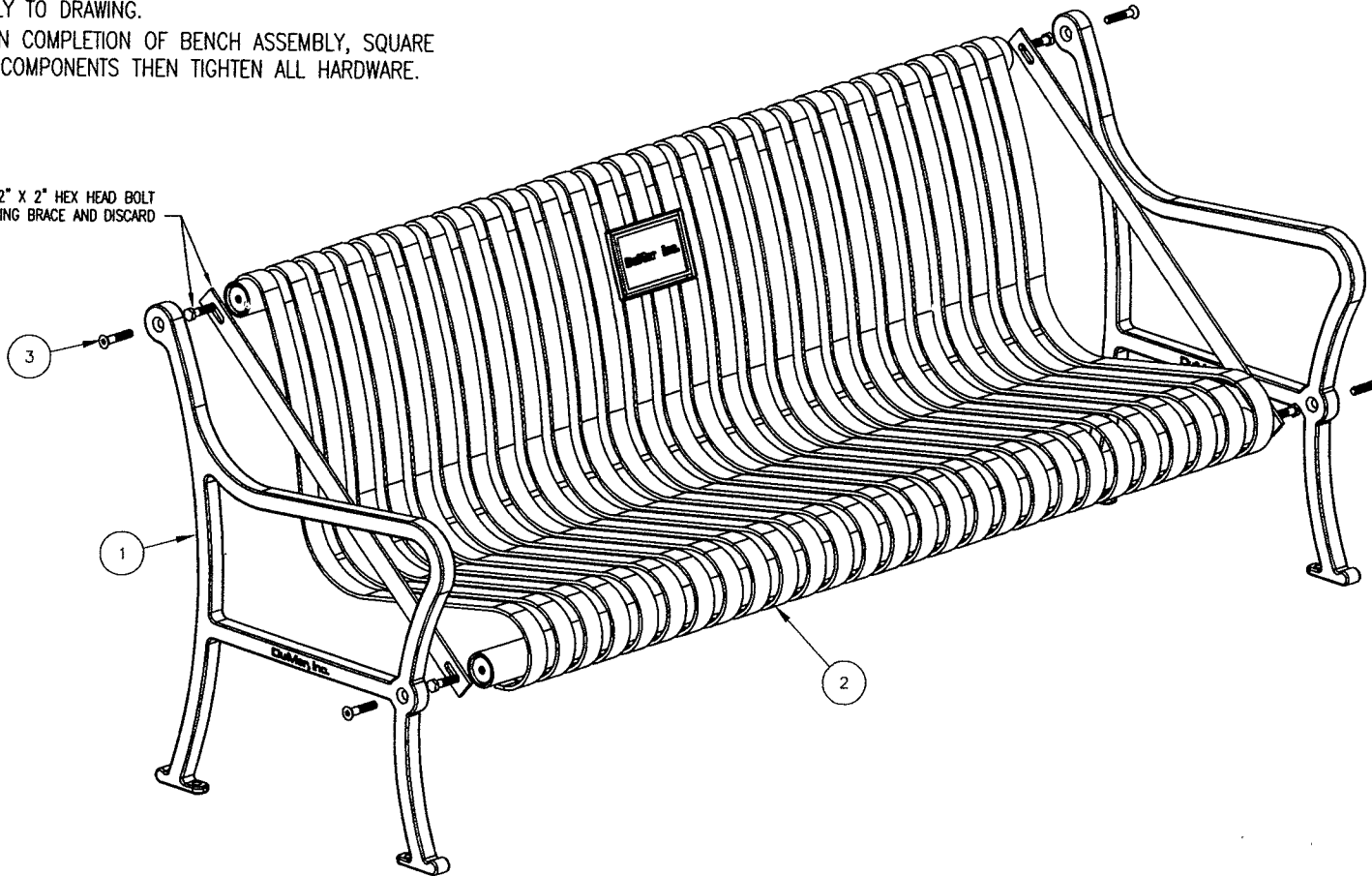

KITS REQUIRED

ITEM	QTY	PART NO	DESCRIPTION
7	1	K-ANC0860-4	1/2" X 3 3/4" SS ANCHOR KIT (4PC)
8	1	K-FC0840-4	1/2" CAP HARDWARE KIT (4 PCS)

ITEM	QTY	PART NO	DESCRIPTION
1	2	0-93-00-02	CAST IRON BENCH SUPPORT
2	1	0-93-60-Q30	6' STL SEAT ASSEMBLY FOR 4X6 PLQ
3	4	1-12-065	1/2" X 2 1/2" FLT SKT HD CAP SCR

DuMor, inc.
 P.O. Box 142 Mifflintown, PA 17059-0142

TOOLS REQ'D
 3/4" WRENCH
 5/16" ALLEN WRENCH
 DRILL & 1/2" MASONRY DRILL BIT

DATE DRAWN : 08/04/09
 DRAWN BY : ESS
 DATE REV. :
 REV. BY :

TITLE **INSTALLATION**
 REVISION **A** DRAWING NUMBER **93 SERIES Q30 SH2**

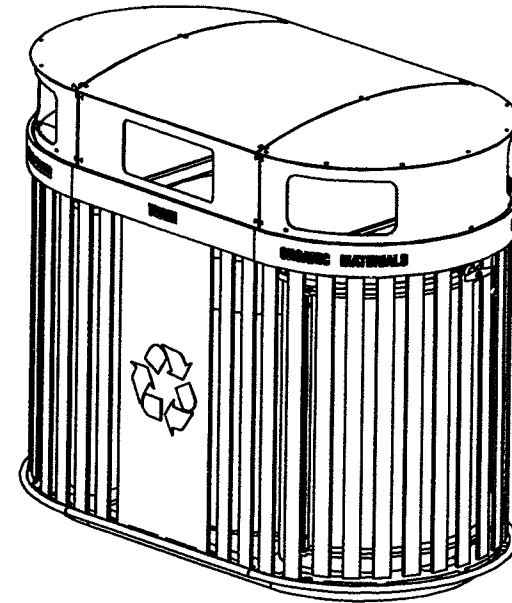
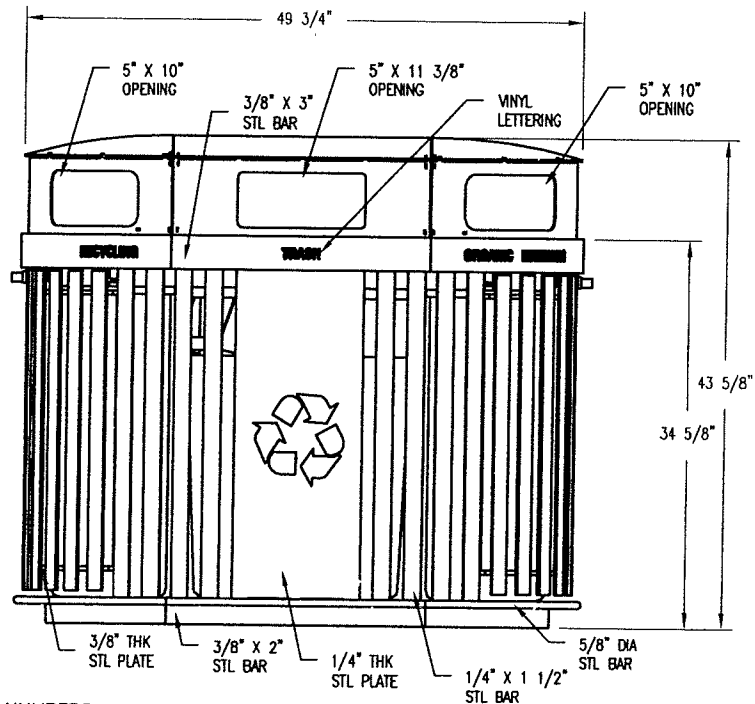
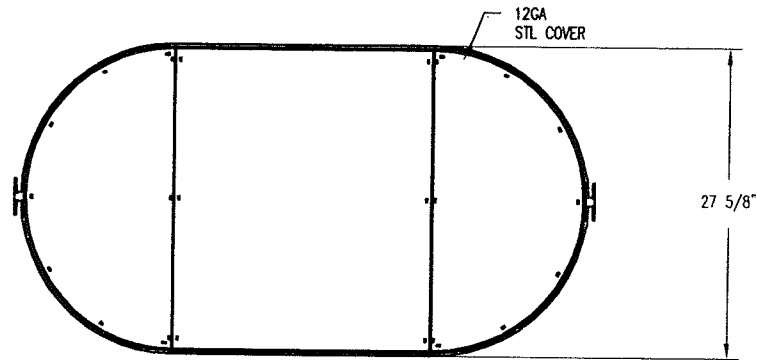

COVER NUMBERS

0-435-EC-04 (2) 5" X 10" OPENING)
 0-435-MC-05 ((2) 5 X 11 3/8" OPENING)
 0-435-EC-04 ((2) 5" X 10" OPENING)

LETTERING LAYOUT

RECYCLING (20 GAL)
 TRASH (32 GAL)
 ORGANIC MATERIALS (20 GAL)

NOTES

- 1.) ALL STL. MEMBERS COATED W/ ZINC RICH EPOXY THEN FINISHED W/ POLYESTER POWDER COATING.
- 2.) 1/2" X 3 3/4" EXPANSION ANCHOR BOLTS PROVIDED (QTY 4).
- 3.) ENDS OF RECYCLING UNIT HINGE FOR REMOVAL OF LINERS.



DuMor, inc.
 P.O. Box 142 Millintown, PA 17059-0142

DATE DRAWN : 4/22/14

DRAWN BY : JSB

DATE REV. :

REV. BY :

TITLE

RECYCLING UNIT

REVISION

A

DRAWING
NUMBER

435-72-0006

JENNIFER CHAPPELL

1036 Ash Street Louisville, Kentucky 40217 | 502.641.7534 | jnnfr.r.chppll@gmail.com

Wednesday, May 28, 2014

Carrie Peers

Legislative Assistant

Metro Council Offices – City Hall

301 West Jefferson Street

Louisville, Kentucky 40202

Dear Carrie Peers:

I have completed the Neighborhood Development Funds application for the Three Points Beautification Project and would like you to review the application so it can be filed by June 2nd. I believe I have included everything, but if you feel it is missing additional information, please don't hesitate to ask for anything.

I'm enclosing copies of:

- The completed NDF form and additional narrative pages;
- Supporting documentation for neighborhood demographics;
- The Three Points Beautification Project Proposal, including a comprehensive contact list of people associated with the project;
- Letters of support from various neighborhood organizations;
- Copies of invoices I have received for the project.

If you have questions, please call me at 502.641.7534 or shoot me an email. Since time is of the essence, I look forward to hearing from you soon.

Thanks for all your help with the project. On behalf of myself and the community, it is greatly appreciated!

Sincerely,

JENNIFER CHAPPELL

ENCLOSURES

CC: KEIDRA KING, LEGISLATIVE ASSISTANT TO DAVID TANDY

INTERNAL REVENUE SERVICE
P. O. BOX 2508
CINCINNATI, OH 45201

DEPARTMENT OF THE TREASURY

Date:

FEB 23 2007

SCHNITZELBURG AREA COMMUNITY
COUNCIL
1343 HICKORY ST
LOUISVILLE, KY 40217

Employer Identification Number:
32-0111959
DLN:
307044022
Contact Person:
EDWARD S SCHLAACK ID# 31536
Contact Telephone Number:
(877) 829-5500
Accounting Period Ending:
December 31
Form 990 Required:
Yes
Effective Date of Exemption:
February 7, 1977
Contribution Deductibility:
No

Dear Applicant:

We are pleased to inform you that upon review of your application for tax-exempt status we have determined that you are exempt from Federal income tax under section 501(c)(4) of the Internal Revenue Code. Because this letter could help resolve any questions regarding your exempt status, you should keep it in your permanent records.

Please see enclosed Information for Organizations Exempt Under Sections Other Than 501(c)(3) for some helpful information about your responsibilities as an exempt organization.

Sincerely,

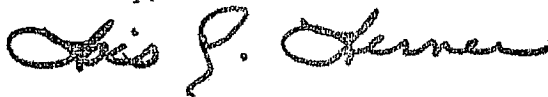

Lois G. Lerner
Director, Exempt Organizations
Rulings and Agreements

Enclosure: Information for Organizations Exempt Under Sections Other Than 501(c)(3)

Letter 948 (DO/CG)



Schnitzelburg Area Community Council

P. O. Box 17306

Louisville, KY 40217

sacc@insightbb.com

www.neighborhoodlink.com/Schnitzelburg_Area_Council

Schnitzelburg Area Community Council Constitution

Article IV

OFFICERS. The Council shall have four principal officers, who shall be the President, Vice-President, Secretary, and Treasurer. These officers shall be elected by the Board of Directors from among the membership of the Board after the annual meeting, to hold office for one year or until their respective successors are elected and take office.

Officers:

Mike Morris – President
947 Goss Avenue
Louisville, KY 40217
(502) 637-4900
mike@mikemorrislaw.com

Susan Brunton – Vice President
1010 Lydia Street
Louisville, KY 40217
(502) 759-7132
10subru10@gmail.com
gogreengermantown@hotmail.com

Kathy Lang - Treasurer
1033 Lydia Street
Louisville, KY 40217
(502) 636-0904
klang1033@gmail.com

David J. (Jake) Wildstrom - Secretary
2352 Dorma Avenue
Louisville, KY 40217
(502) 509-6284
dwildstr@gmail.com

At Large Board Members:

Shane Smith
896 Eastern Pkwy
Louisville, KY 40217
(502) 396-9767
shanesmith@bellsouth.net

Paul Boblitt
1258 Lydia Street
Louisville, KY 40217
(502) 744-9124
paulycb1@hotmail.com

Lisa Pisterman
1315 McHenry Street
Louisville, KY 40217
(502) 802-8790
germantownpast@yahoo.com

Jennifer Chappell
1036 Ash Street
Louisville, KY 40217
(502) 641-7534
jnnfr.r.chppll@gmail.com

David Pisterman
1315 McHenry Street
Louisville, KY 40217
(502) 802-8790
david.pisterman@gmail.com

Nadine LePore
1160 S Brook Street Apt 1
Louisville, KY 40203
(502)797-7299
Nadineloves@gmail.com

Dan McMahon
830 Texas Avenue
Louisville, KY 40217
(502) 635-7995
dannymacmobile@aol.com

Dianna Morris
947 Goss Avenue
Louisville, KY 40217
(502) 637-4900
diannazeigler@bellsouth.net

Gary Liebert
921 Mulberry Street
Louisville, KY 40217
(502) 533-3322
gary.liebert@gmail.com

Stephan D. Cambron
911 Ash Street
Louisville KY 40217
502-609-6389
babiepossum@yahoo.com

Julianne Thomas
1033 Ash Street
Louisville, KY 40217
(502) 634-0127
jthomas25@insightbb.com

Form **990-N**
 Department of the Treasury
 Internal Revenue Service

**Electronic Notice (e-
 Postcard)**

for Tax-Exempt Organizations not
 Required To File Form 990 or 990-EZ

OMB No.
 1545-2085

2012

Open to
 Public
 Inspection

A For the 2012 calendar year, or tax year beginning 1/1/2012, and ending 12/31/2012.

B Check if applicable

- Terminated, Out of Business
 Gross receipts are normally \$50,000 or less

E Website:

www.neighborhoodlink.com/SchnitzelburgAreaCouncil-LINC

C Name of organization: SCHNITZELBURG
 AREA COMMUNITY COUNCIL
 d/b/a:

% Kathy Lang
P O Box 17306
Louisville, KY, US, 40217

D Employer
 Identification
 Number
32-0111959

F Name of Principal Officer: Kathy Lang

P O Box 17306
Louisville, KY, US, 40217

Privacy Act and Paperwork Reduction Act Notice. We ask for the information on this form to carry out the Internal Revenue laws of the United States. You are required to give us the information. We need it to ensure that you are complying with these laws.

The organization is not required to provide the information requested on a form that is subject to the Paperwork Reduction Act unless the form displays a valid OMB control number. Books or records relating to a form or its instructions must be retained as long as their contents may become material in the administration of any Internal Revenue law. The rules governing the confidentiality of the Form 990-N is covered in Code section 6104.

The time needed to complete and file this form and related schedules will vary depending on individual circumstances. The estimated average times is 15 minutes.

Note: This image is provided for your records only. Do NOT mail this page to the IRS. The IRS will not accept this filing via paper. You must file your Form 990-N (e-Postcard) electronically.

ORIGINAL COPY
FILED AND RECORDED
OFFICE OF THE SECRETARY OF STATE
COLUMBIA, KENTUCKY

SECRETARY OF STATE
RECEIVED

JAN 21 1977

ARTICLES OF INCORPORATION

FOR

D. Schnitzelburg
The Schnitzelburg Area Community Council, Inc. Commonwealth of Kentucky

The undersigned, the majority of whom are citizens of the United States of America, desiring to form a non-profit corporation law of the Commonwealth of Kentucky, do hereby certify:

46536

ARTICLE I

The name of the corporation shall be The Schnitzelburg Area Community Council, Inc.

ARTICLE II

Unless sooner terminated as provided by law, the Area Community Council shall have perpetual existence from the time the certificate of incorporation has been issued by the Secretary of the State of Kentucky.

ARTICLE III

The objects and purposes of the Area Community Council shall be:

- a. To unite property owners, tenants, business people and others interested in the area.
- b. To encourage civic improvements and betterments in the area.
- c. To promote community activities and interests of an educational or civic nature.
- d. To encourage residential and business property upkeep in the area, and to eliminate vandalism and littering.
- e. To encourage better fire and police protection, traffic flow and traffic law enforcement in the area.
- f. To be concerned with youth problems of the area.
- g. To encourage reasonable and adequate zoning, and to ensure uniform enforcement of codes.
- h. To encourage a spirit of friendliness and cooperative community spirit in the area and in relations with other groups in the Schnitzelburg Area and throughout the City of Louisville.
- i. To support any other activities which advance the common good and general welfare of the community and its people unless these activities are excluded by IRC Sec. 501 (c) (4) or IRS regulation.

ARTICLE IV

(4.1) The said Area Community Council is organized exclusively for the promotion of social and civic welfare as described in IRC Sec. 501 (c) (4). In view of that fact, no part of the net earnings of the Council shall be distributable to its members, directors, officers, and other private persons as income; however, the corporation shall be authorized and empowered to pay reasonable compensation for services rendered and to make payments and distributions in furtherance of the purposes set forth in Article Three hereof.

(4.2) No substantial part of the activities of the Area Community Council shall be the carrying on of propaganda, or otherwise attempting to influence legislation, unless the social welfare and civic objective require legislation as per the regulations concerning IRC Sec. 501 (c) (4) or intervene in any political campaign on behalf of any candidate for public office.

(4.3) Notwithstanding any other provision of these articles, the Area Community Council shall not carry on any other activities not permitted to be carried on by a corporation exempt from Federal Income Tax under Sec. 501 (c) (4) of the Internal Revenue Code of 1954.

(4.4) Upon dissolution of the Area Community Council, the Board of directors shall, after paying or making provision for the payment of all the liabilities of the Area Community Council, dispose of all the assets of the Area Community Council exclusively for the purposes of the Area Community Council in such manner, or to such organization or organizations established and operated exclusively for social welfare or civic purposes as shall at the time qualify as exempt organization or organizations under Sec. 501 (c) (4) Internal Revenue Code of 1954 as the Board of Directors shall determine. Any such assets not so disposed of shall be disposed of by the Court of Common Pleas of the county in which the principal office of the Corporation is then located, exclusively for such purposes or to such organization or organizations, as said Court shall determine, which are organized and operated exclusively for such purposes.

ARTICLE V

(5.1) The registered office and place of business of the corporation shall be: William Keely, 529 Krawick, Louisville, Jefferson County, Kentucky 40217.

(5.2) The name and address of its resident agent for the service of process shall be: William Keely, President, 529 Krawick, Louisville, Kentucky 40217.

ARTICLE VI

The officers, directors, or members of the Area Community Council shall not be personally liable for payment of debts, liabilities, or obligations of the Council to any extent whatsoever.

ARTICLE VII

(7.1) The initial board of directors shall consist of thirteen members on the board and four officers selected from the board.

(7.2) The following individuals will serve in the capacity of ~~officers~~ ^{directors} until the selection of their successors:

President: William Keely, 819 Keswick, Louisville, Ky., 40217

Vice-President: Gregory Sargent, 942 Mulberry, Louisville, Ky., 40217

Secretary: James Peak, 1021 Wagner, Louisville, Ky., 40217

Treasurer: William Tinker, 1245 Milton, Louisville, Ky., 40217

IN WITNESS thereof, we have hereunto subscribed our names this 26 day of June, 1977.

Notary Public

H. F. Schmidt

William Keely

Wm W. Tinker

James Peak
Gregory Sargent

RECEIVED NOV 15 2005

0078158.09

Trey Grayson
Secretary of State
Received and Filed
11/09/2005 11:22:11 AM
Fee Receipt: \$8.00

Chance
NAOA

ARTICLES OF AMENDMENT
OF
SCHNITZELBURG AREA COMMUNITY COUNCIL, INC.

ARTICLE XIII: Amendment

Section 1

Pursuant to a meeting of the members of this corporation held on Monday, September 26, 2005, of which a quorum was present at said meeting, the following amendment was received and unanimously adopted and accepted by the quorum present. The amendment adopted is set forth below:

Section 2: The original Articles of Incorporation for the Schnitzelburg Area Community Council, Inc., are hereby amended to reflect that Article 3, Section I, is hereby amended to read that:

To support any activities which advance the common good and general of the community and its people unless these activities are excluded by IRS Sec. 501(c)(3).

APPROVED AND SUBMITTED by William W. Tinker, Jr. Treasurer and Director for the Schnitzelburg Area Community Council, Inc.

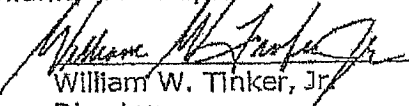
William W. Tinker, Jr.
Director

APPROVED: September 26, 2005

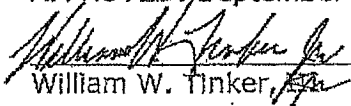
William W. Tinker, Jr.

Commonwealth of Kentucky

OFFICE OF
SECRETARY OF STATE

DREXELL R. DAVIS
Secretary



FRANKFORT,
KENTUCKY

CERTIFICATE OF INCORPORATION OF NON-STOCK, NON-PROFIT CORPORATION

I, DREXELL R. DAVIS, Secretary of State of the Commonwealth of Kentucky
certify that there has been delivered to my office articles of incorporation of
THE SCHWITZFELDER ANPA COMMUNITY CENTER, INC.

The name and address of the registered agent of this corporation is
WILLIAM KEELY

NAME 319 RESWICK
STREET ADDRESS LOUISVILLE, KENTUCKY 40217
CITY STATE

NOW, THEREFORE, finding that these articles of incorporation conform to law
and that all fees therefor having been paid as prescribed by law, I, DREXELL R.
DAVIS, Secretary of State, issue this Certificate of Incorporation.

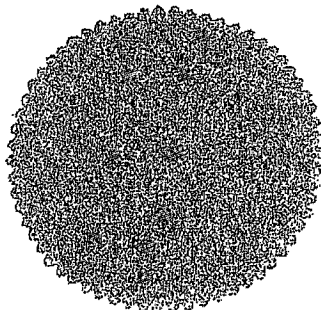

SECRETARY OF STATE

Issued this 7th day of FEBRUARY, 19 77.

at Frankfort, Kentucky.

Drexell R. Davis
SECRETARY OF STATE

ASSOCIATE SECRETARY OF STATE

THE SCHNITZELBURG AREA COMMUNITY COUNCIL, INC.

General Information

Organization Number	0078158
Name	THE SCHNITZELBURG AREA COMMUNITY COUNCIL, INC.
Profit or Non-Profit	N - Non-profit
Company Type	KCO - Kentucky Corporation
Status	A - Active
Standing	G - Good
State	KY
File Date	2/7/1977
Organization Date	2/7/1977
Last Annual Report	3/18/2014
Principal Office	P. O. BOX 17306 LOUISVILLE, KY 40217
Registered Agent	KATHY LANG 1033 LYDIA STREET LOUISVILLE, KY 40217

Current Officers

President	<u>MIKE MORRIS</u>
Vice President	<u>SUSAN BRUNTON</u>
Secretary	<u>JAKE WILDSTROM</u>
Treasurer	<u>KATHY LANG</u>
Director	<u>MIKE MORRIS</u>
Director	<u>SUSAN BRUNTON</u>
Director	<u>KATHY LANG</u>
Director	<u>JAKE WILDSTROM</u>

Individuals / Entities listed at time of formation

Director	<u>WILLIAM KEELY</u>
Director	<u>GREGORY SARJENT</u>
Director	<u>JAMES PEAK</u>
Director	<u>WILLIAM TINKER</u>
Incorporator	<u>WILLIAM KEELY</u>
Incorporator	<u>JAMES PEAK</u>
Incorporator	<u>WILLIAM TINKER</u>
Incorporator	<u>GREGORY SARJENT</u>

Images available online

Documents filed with the Office of the Secretary of State on September 15, 2004 or thereafter are available as scanned images or PDF documents. Documents filed prior to September 15, 2004 will become available as the images are created.

Annual Report

3/18/2014

1 page

PDF



Trey Grayson
Secretary of State

Certificate of Existence

I, Trey Grayson, Secretary of State of the Commonwealth of Kentucky, do hereby certify that according to the records in the Office of the Secretary of State,

THE SCHNITZELBURG AREA COMMUNITY COUNCIL, INC.

has eliminated all the grounds for dissolution, paid all fees and penalties owed to the Secretary of State, and met all other requirements for reinstatement. The effective date of reinstatement is October 7, 2004.

I further certify that THE SCHNITZELBURG AREA COMMUNITY COUNCIL, INC. is a corporation duly organized and existing under the laws of the Commonwealth of Kentucky, whose date of incorporation is February 7, 1977, and whose period of duration is perpetual.

IN WITNESS WHEREOF, I have hereunto set my hand and affixed my Official Seal at Frankfort, Kentucky, this 7th day of October, 2004.

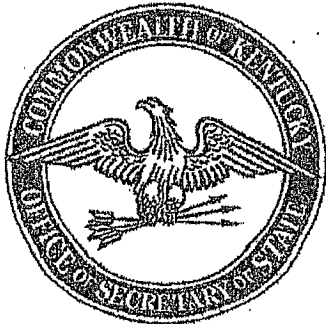

T. Grayson
Trey Grayson
Secretary of State
Commonwealth of Kentucky
MMcCrillch/0078158

Request for Taxpayer Identification Number and Certification

**Give Form to the
requester. Do not
send to the IRS.**

Print or type
See Specific Instructions on page 2.

Name (as shown on your income tax return) SCHNITZELBURG AREA COMMUNITY COUNCIL, INC.	
Business name/disregarded entity name, if different from above	
Check appropriate box for federal tax classification: <input type="checkbox"/> Individual/sole proprietor <input type="checkbox"/> C Corporation <input type="checkbox"/> S Corporation <input type="checkbox"/> Partnership <input type="checkbox"/> Trust/estate <input type="checkbox"/> Limited liability company. Enter the tax classification (C=C corporation, S=S corporation, P=partnership) ▶ _____ <input checked="" type="checkbox"/> Exempt payee <input type="checkbox"/> Other (see instructions) ▶ _____	
Address (number, street, and apt. or suite no.) P. O. Box 17306	Requester's name and address (optional)
City, state, and ZIP code Louisville KY 40217	
List account number(s) here (optional)	

Part I Taxpayer Identification Number (TIN)

Enter your TIN in the appropriate box. The TIN provided must match the name given on the "Name" line to avoid backup withholding. For individuals, this is your social security number (SSN). However, for a resident alien, sole proprietor, or disregarded entity, see the Part I instructions on page 3. For other entities, it is your employer identification number (EIN). If you do not have a number, see *How to get a TIN* on page 3.

Social security number								

Note. If the account is in more than one name, see the chart on page 4 for guidelines on whose number to enter.

Employer identification number									
3	2	-	0	1	1	1	9	5	9

Part II Certification

Under penalties of perjury, I certify that:

1. The number shown on this form is my correct taxpayer identification number (or I am waiting for a number to be issued to me), and
2. I am not subject to backup withholding because: (a) I am exempt from backup withholding, or (b) I have not been notified by the Internal Revenue Service (IRS) that I am subject to backup withholding as a result of a failure to report all interest or dividends, or (c) the IRS has notified me that I am no longer subject to backup withholding, and
3. I am a U.S. citizen or other U.S. person (defined below).

Certification instructions. You must cross out item 2 above if you have been notified by the IRS that you are currently subject to backup withholding because you have failed to report all interest and dividends on your tax return. For real estate transactions, item 2 does not apply. For mortgage interest paid, acquisition or abandonment of secured property, cancellation of debt, contributions to an individual retirement arrangement (IRA), and generally, payments other than interest and dividends, you are not required to sign the certification, but you must provide your correct TIN. See the instructions on page 4.

Sign Here Signature of U.S. person ▶ *William M. Gray*

Date ▶ *10/14/13*

General Instructions

Section references are to the Internal Revenue Code unless otherwise noted.

Purpose of Form

A person who is required to file an information return with the IRS must obtain your correct taxpayer identification number (TIN) to report, for example, income paid to you, real estate transactions, mortgage interest you paid, acquisition or abandonment of secured property, cancellation of debt, or contributions you made to an IRA.

Use Form W-9 only if you are a U.S. person (including a resident alien), to provide your correct TIN to the person requesting it (the requester) and, when applicable, to:

1. Certify that the TIN you are giving is correct (or you are waiting for a number to be issued),
2. Certify that you are not subject to backup withholding, or
3. Claim exemption from backup withholding if you are a U.S. exempt payee. If applicable, you are also certifying that as a U.S. person, your allocable share of any partnership income from a U.S. trade or business is not subject to the withholding tax on foreign partners' share of effectively connected income.

Note. If a requester gives you a form other than Form W-9 to request your TIN, you must use the requester's form if it is substantially similar to this Form W-9.

Definition of a U.S. person. For federal tax purposes, you are considered a U.S. person if you are:

- An individual who is a U.S. citizen or U.S. resident alien,
- A partnership, corporation, company, or association created or organized in the United States or under the laws of the United States,
- An estate (other than a foreign estate), or
- A domestic trust (as defined in Regulations section 301.7701-7).

Special rules for partnerships. Partnerships that conduct a trade or business in the United States are generally required to pay a withholding tax on any foreign partners' share of income from such business. Further, in certain cases where a Form W-9 has not been received, a partnership is required to presume that a partner is a foreign person, and pay the withholding tax. Therefore, if you are a U.S. person that is a partner in a partnership conducting a trade or business in the United States, provide Form W-9 to the partnership to establish your U.S. status and avoid withholding on your share of partnership income.

NDF NON-PROFIT APPLICATION CHECKLIST

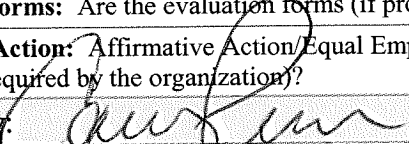
Legal Name of Applicant Organization: Schnitzelburg Area Community Council			
Program Name:	3 Points Beautification	Request Amount:	6,500.00
			Yes/No/NA
Request form:	Is the NDF request form signed by all Council Member(s) appropriating funding?		
	Yes		
Request form:	Is the funding proposed less than or equal to the request amount?		
	Yes		
Request form:	Have all known Council or Staff relationships to the Agency been adequately disclosed on the cover sheet?		
	Yes		
Application Page 1:	Has prior Metro funds committed/granted been disclosed?		
	Yes		
Application Page 1:	Is the application properly signed and dated by authorized signatory?		
	Yes		
Application Page 3:	Reimbursement funding – One or two boxes checked if any expenses are incurred before the grant award period. Is all required documentation included?		
	n/a		
Application Pages 3 – 5:	Is the proposed public purpose of the program well-documented?		
	Yes		
Application 4:	Is there adequate documentation of how the proceeds of the fundraiser will be spent?		
	n/a		
Application Budget Page 6:	Does the application budget reflect only the revenue and expenses of the project/program (page 6) if the request is not an operating budget request? Is all detail schedules included for “Metro, Non Metro and Total” expense funds for client assistance, community events & festivals and other expenses? And does the Non-Metro Revenue equal the Non-Metro expenses?		
	Yes		
Faith Based Organizations:	Is the signed Faith Based Form signed and included?		
	n/a		
Jefferson County Only:	Will all funding be spent in Louisville/Jefferson County?		
	Yes		
Capital Project(s) request:	Is the cost estimate(s) from proposed vendor(s) included?		
	Yes		
Good Standing:	Is the entity in good standing with:		
	<ul style="list-style-type: none"> • Kentucky Secretary of State – include Secretary of State website information on organization • Louisville Metro Government – check OMB monthly report filed in Council Financial Reports • Internal Revenue Service – most recent Form 990 included 		
	Yes		
Separate Taxing Districts:	If Metro funding is for a separate taxing district, is the funding appropriated for a program outside the legal responsibility of that taxing district?		
	n/a		
Small Cities:	Is the resolution included agreeing to partner with Louisville Metro on the capital project? (IRS Determination letter not required, Form 990 not required, but KY SOS acknowledgement is)		
	n/a		
Operating Requests:	Is recommended operating funding less than or equal to 33% of total operating budget?		
	n/a		
IRS Exempt Proof:	Is proof of Tax Exempt status of 501(c) 3, 4, 6, 19, 1120-H included?		
	Yes		
Operating Budget:	Is the organization’s current fiscal year operating budget included?		
	Yes		
Ordinance Required:	Is the amount committed by Council members greater than \$5,000 to any one project/program within an organization in this fiscal year.		
	Yes		
Board Members:	Is the entity’s board member list (with term length/term limits) included?		
	Yes		
Staff:	Is a list of the highest paid staff included with their expected annual personnel costs?		
	n/a		
Annual Audit:	Is the most recent annual audit (if required by organization) included?		
	n/a		
Rent Requests:	Is a copy of signed lease included?		
	n/a		
Articles of Incorporation:	Are the Articles of Incorporation of the organization included?		
	Yes		
IRS Form W-9:	Is the IRS Form W-9 included?		
	Yes		
Evaluation Forms:	Are the evaluation forms (if program participants are given evaluation forms) included?		
	n/a		
Affirmative Action:	Affirmative Action/Equal Employment Opportunity plan and/or policy statement included (if required by the organization)?		
	n/a		
Prepared by:			Date: 4/9/14

Smith, Chanelle Emily

From: Stenberg, Beth
Sent: Tuesday, August 05, 2014 12:00 PM
To: Smith, Chanelle Emily
Cc: Stenberg, Beth
Subject: FW: Three Points NDF

Follow Up Flag: Follow up
Flag Status: Completed

Chanelle, please put this in the packet that will go to OMB for their information. You don't necessarily have to upload it with the documentation.

From: Jennifer Chappell [<mailto:jnnfr.r.chppl@gmail.com>]
Sent: Tuesday, August 05, 2014 11:38 AM
To: Stenberg, Beth
Subject: Three Points NDF

Beth,

Mike printed out your email and gave it to me last night at our SACC meeting.

The Three Points NDF is dated for June and it required those timelines, HOWEVER, this project CANNOT move forward without the NDF money. Therefore, the date has been pushed back since the NDF process has taken longer than expected. This is NOT a reimbursement and once we get the money, it will be spent within 60 days or less of receiving it. Do I need to change anything on the form?

I desperately need to know when we are getting the money. As I said, this entire project is being planned around when we are getting these funds. We were supposed to start at the end of July, then it was the end of August, and now it is ?????? One of the artists has an internship in NYC and is flying here to work on the project. We would all like to know when we should expect this money. In your email to Mike it made it seem like we won't be getting any money until the middle to end of September. I need a timeline!!!

If you have any questions please give me a call at the number below or email me. I work a block away from Metro Hall, so I can walk over to your office if need be.

--

Jennifer Chappell
502.641.7534