

154767

GARY GARAGE/SCREENED PORCH

1/8" = 1'-0"

6/1/15

511 MACON AVE

RECEIVED
JUN 05 2015
PLANNING &
DESIGN SERVICES

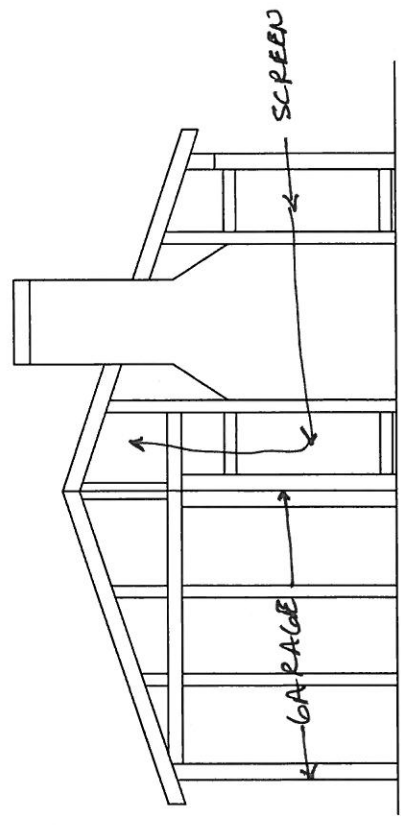

REAR ELEVATION - FACING
REAR PROPERTY LINE

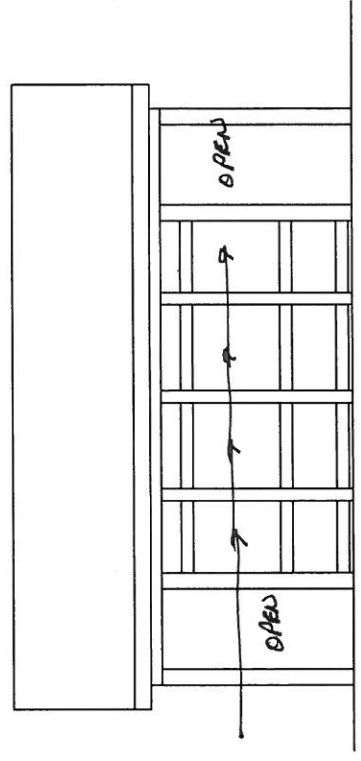

PORCH SIDE ELEVATION

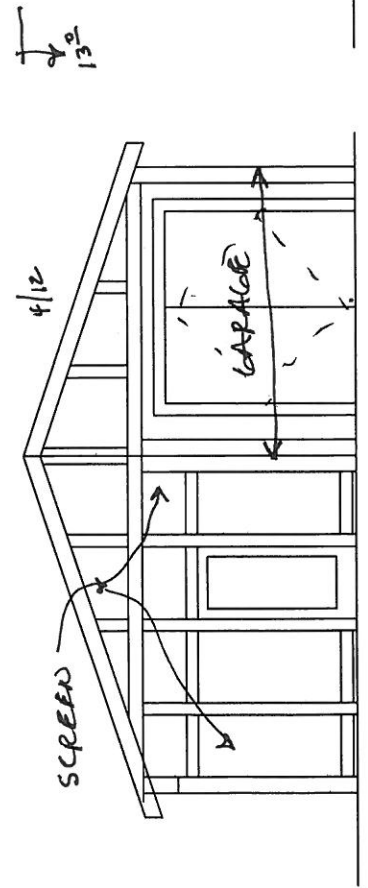

SCREENED PORCH, GARAGE
FRONT ELEVATION - FACING HOUSE

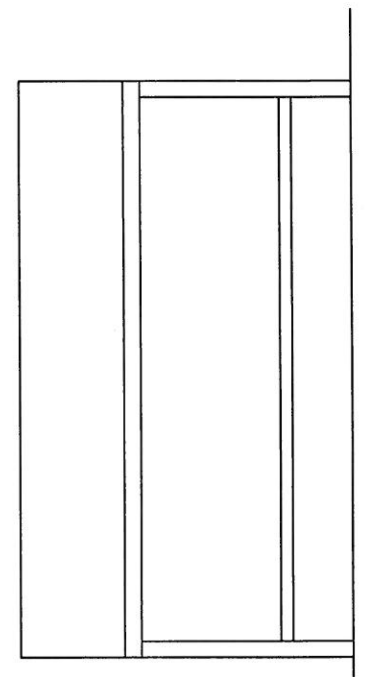

SIDE GARAGE ELEVATION - FACING
SIDE PROPERTY LINE