

**GENERAL NOTES:**

- DOMESTIC WATER SUPPLY:  
SUBJECT SITE CAN BE SERVED BY THE LOUISVILLE WATER COMPANY. THE NECESSARY WATER SYSTEM IMPROVEMENTS REQUIRED TO SERVICE THE DEVELOPMENT SHALL BE AT THE OWNER/DEVELOPER'S EXPENSE.
- TREE PRESERVATION:  
A TREE PRESERVATION PLAN SHALL BE PROVIDED TO THE PLANNING COMMISSION'S STAFF LANDSCAPE ARCHITECT FOR APPROVAL PRIOR TO BEGINNING ANY CONSTRUCTION ACTIVITIES ON THE SITE.
- PROTECTION OF TREES TO BE PRESERVED:  
CONSTRUCTION FENCING SHALL BE ERRECTED PRIOR TO ANY GRADING OR CONSTRUCTION ACTIVITIES—PREVENTING COMPACTION OF ROOT SYSTEMS OF TREES TO BE PRESERVED. THE FENCING SHALL ENCLOSE THE AREA BENEATH THE DRIP LINE OF THE TREE CANOPY AND SHALL REMAIN IN PLACE UNTIL ALL CONSTRUCTION IS COMPLETE. NO PARKING, MATERIAL STORAGE OR CONSTRUCTION ACTIVITIES SHALL BE PERMITTED WITHIN THE FENCED AREA.
- A LANDSCAPE AND TREE CANOPY PLAN PER CHAPTER 10 OF THE LDC SHALL BE PROVIDED AS REQUIRED PRIOR TO ISSUANCE OF BUILDING PERMIT.
- THE DEVELOPMENT LIES IN THE ST. MATTHEWS FIRE DISTRICT.
- ALL LUMINAIRES SHALL BE AIMED, DIRECTED OR FOCUSED SUCH AS TO NOT CAUSE DIRECT LIGHT FROM THE LUMINAIRE TO BE DIRECTED TOWARDS RESIDENTIAL USES OR PROJECTED OPEN SPACES (IE. CONSERVATION EASEMENTS, GREENWAYS OR PARKWAYS) ON ADJACENT OR NEARBY PARCEL'S, OR TO CREATE GLARE PERCEPTIBLE ON PUBLIC STREETS AND RIGHT-OF-WAYS PER CHAPTER 4.1.3. OF THE LDC.
- ALL DUMPSTER PADS, TRANSFORMERS, AC UNITS, GENERATOR PADS TO BE SCREENED PER CHAPTER 10 OF THE LDC.
- BUILDING ARCHITECTURE TO COMPLY WITH CHAPTER 5.6 OF THE LDC.
- ALL INTERIOR SIDEWALKS THAT ABUT PARKING TO BE FIVE (5) FEET WIDE MINIMUM. PARKING AREAS SHALL COMPLY WITH 9.1.12.C OF THE LDC.
- MITIGATION MEASURES FOR DUST CONTROL SHALL BE IN PLACE DURING CONSTRUCTION TO PREVENT FUGITIVE EMISSIONS REACHING EXISTING ROADS AND NEIGHBORHOODS.
- ALL EXISTING STRUCTURES AND EXISTING ENTRANCES SHALL BE REMOVED.
- IN ACCORDANCE WITH CHAPTER 4.9 OF THE LDC, A KARST SURVEY WAS PERFORMED BY TRAVIS BROWN ON 01/08/2020 AND NO KARST TOPOGRAPHY WAS FOUND. A REVIEW OF PUBLISHED GEOLOGIC INFORMATION FROM THE KY GEOLOGICAL SURVEY CONTAINED NO INDICATION OF SINKHOLES ON THE SUBJECT PROPERTY.
- THE EXISTING LOTS SHALL BE CONSOLIDATED BY DEED.
- THE PROPOSED BUILDING SHALL BE NO CLOSER TO FOUNTAIN AVENUE THAN THOSE LOCATED AT 911 & 913 FOUNTAIN AVENUE IN ACCORDANCE WITH 5.1.12.B OF THE LDC.

**MSD NOTES:**

- CONSTRUCTION PLANS & DOCUMENTS SHALL COMPLY WITH LOUISVILLE AND JEFFERSON COUNTY METROPOLITAN SEWER DISTRICT'S DESIGN MANUAL AND STANDARD SPECIFICATIONS.
- WASTEWATER:  
SANITARY SEWER BY CONNECTION TO THE MORRIS FORMAN WASTEWATER TREATMENT PLANT, SUBJECT TO FEES. SANITARY SEWER CAPACITY TO BE APPROVED BY METROPOLITAN SEWER DISTRICT.
- DRAINAGE/STORMWATER DETENTION:  
DETENTION TO BE COMPENSATED THROUGH REGIONAL FACILITY FEES. DRAINAGE PATTERN (DEPICTED BY FLOW ARROWS) IS FOR CONCEPT PURPOSES ONLY. FINAL CONFIGURATION AND SIZE OF DRAINAGE PIPES AND CHANNELS SHALL BE DETERMINED DURING THE CONSTRUCTION PLAN DESIGN PROCESS. DRAINAGE FACILITIES SHALL CONFORM TO MSD REQUIREMENTS.
- EROSION AND SILT CONTROL:  
A SOIL AND SEDIMENTATION CONTROL PLAN SHALL BE DEVELOPED AND IMPLEMENTED IN ACCORDANCE WITH MSD AND THE USDA NATURAL RESOURCES CONSERVATION SERVICE RECOMMENDATIONS.
- NO PORTION OF THE SUBJECT PROPERTY LIES WITHIN A FLOOD HAZARD AREA PER FEMA'S FIRM MAPPING (2111100 30E).
- THE DEVELOPER SHALL SIZE AND INSTALL A REPLACEMENT TRENCH DRAIN ACROSS THE DRIVEWAY OF 913 FOUNTAIN AVENUE.

**PUBLIC WORKS AND KTC NOTES:**

- NO LANDSCAPING AND COMMERCIAL SIGNS SHALL BE PERMITTED IN STATE AND METRO WORKS RIGHT-OF-WAY WITHOUT AN ENCROACHMENT PERMIT.
- VERGE AREA WITH PUBLIC RIGHT-OF-WAY TO BE PROVIDED PER METRO PUBLIC WORKS.
- COMPATIBLE UTILITY LINES (ELECTRIC, PHONE, CABLE) SHALL BE PLACED IN A COMMON TRENCH UNLESS OTHERWISE REQUIRED BY APPROPRIATE AGENCIES.
- AN ENCROACHMENT PERMIT AND BOND MAY BE REQUIRED BY METRO PUBLIC WORKS FOR ROADWAY REPAIRS ON ALL SURROUNDING ACCESS ROADS TO THE SITE DUE TO DAMAGES CAUSED BY CONSTRUCTION TRAFFIC ACTIVITIES.
- THE DEVELOPER IS RESPONSIBLE FOR ANY UTILITY RELOCATION ON THE PROPERTY.
- ALL SIDEWALK RAMP SHALL CONFORM TO A.D.A. STANDARD SPECIFICATION, THE "SPECIAL NOTE FOR DETECTABLE WARNING FOR SIDEWALK RAMP" PER KTC STANDARD DRAWING FOR SIDEWALKS AND PER KENTUCKY STANDARD SPECIFICATIONS FOR ROAD AND BRIDGE CONSTRUCTION, LATEST EDITION.
- THERE SHALL BE NO INCREASE IN DRAINAGE RUNOFF TO THE RIGHT-OF-WAY. CALCULATIONS WILL BE REQUIRED FOR ANY RUNOFF TO THE STATE RIGHT-OF-WAY.
- SITE LIGHTING SHALL NOT SHINE IN THE EYES OF DRIVERS. IF IT DOES, IT SHALL BE RE- AIMED, SHIELDED OR TURNED OFF.
- METRO WORKS BOND AND ENCROACHMENT PERMIT WILL BE REQUIRED FOR ALL WORK DONE WITHIN THE PUBLIC RIGHT-OF-WAY.
- DEVELOPER SHALL IMPROVE FOUNTAIN AVENUE TO PROVIDE 22' OF PAVEMENT BETWEEN WESTPORT ROAD AND THE ENTRANCE TO THE SITES' PARKING LOT AS REQUIRED BY METRO PUBLIC WORKS.

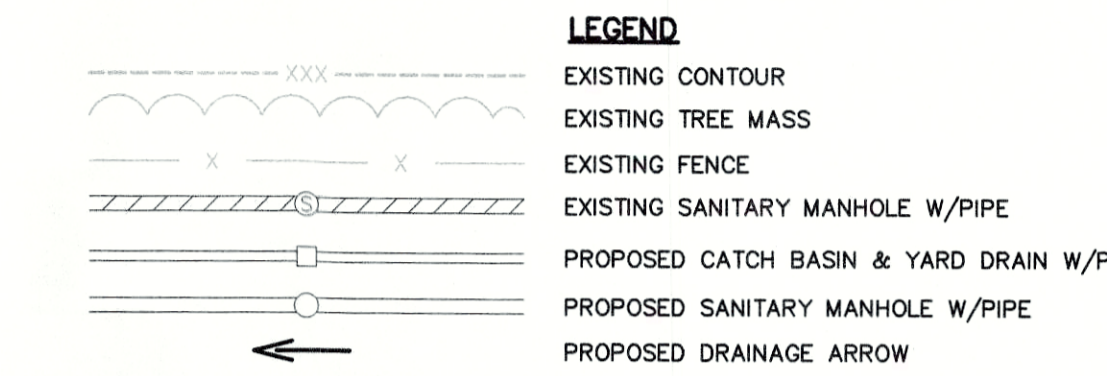
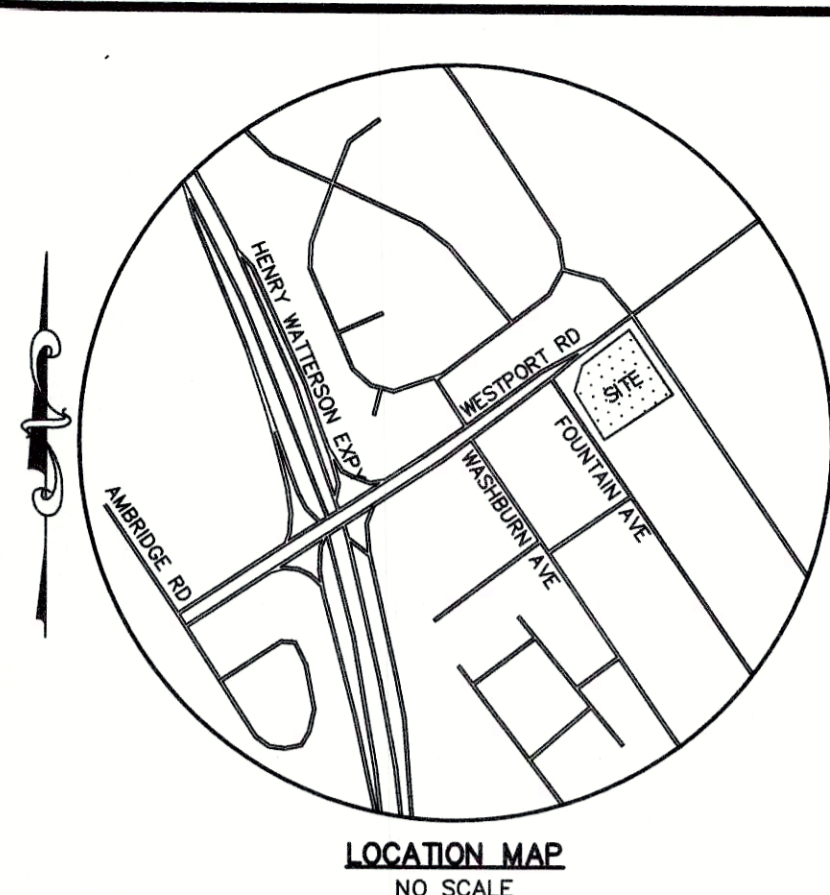
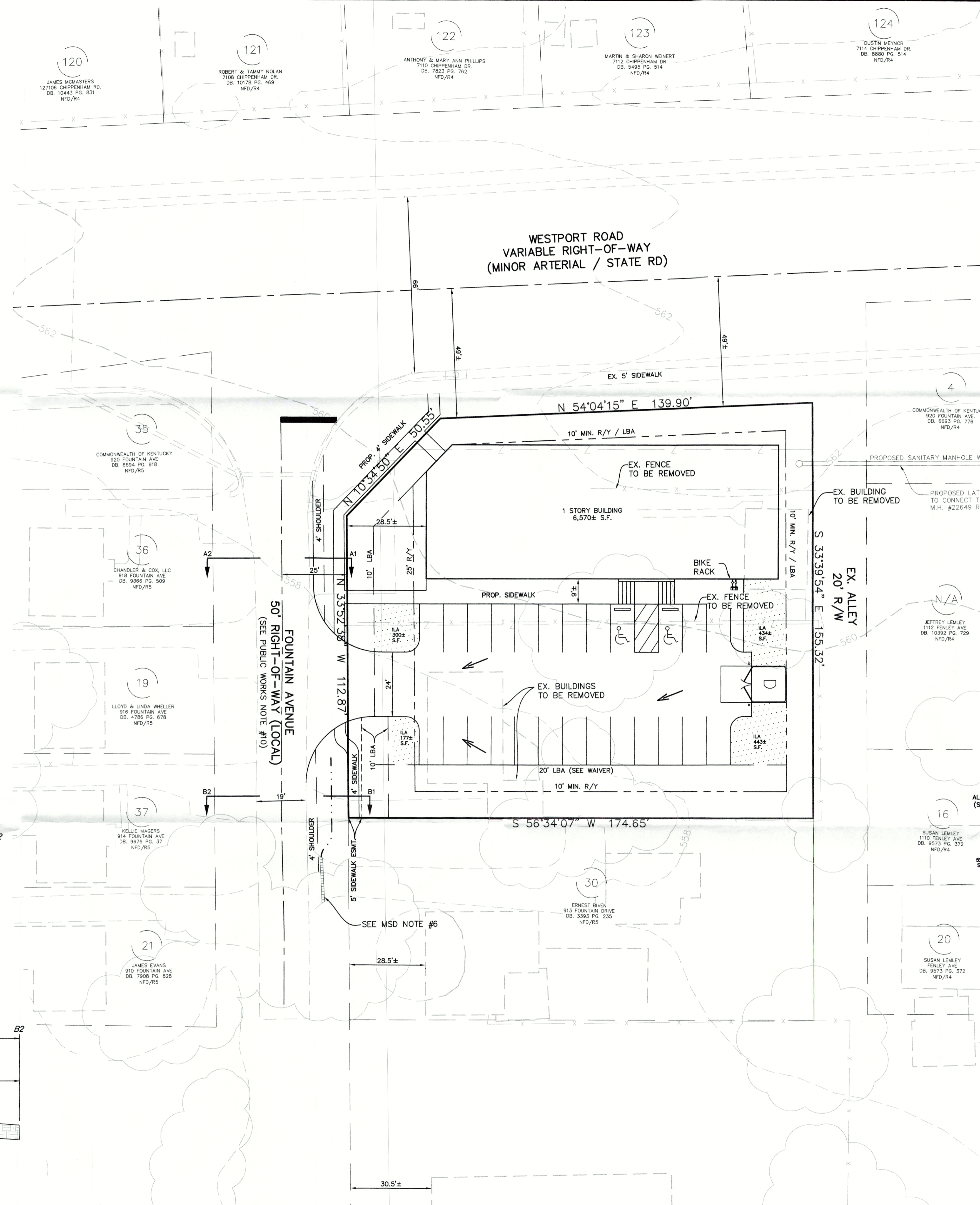

**SITE DATA:**

EXISTING FORM DISTRICT	NEIGHBORHOOD
EXISTING ZONING	R5
PROPOSED ZONING	C1
EXISTING LAND USE	VACANT
PROPOSED LAND USE	GENERAL RETAIL
TOTAL LAND AREA	0.59± AC.
BUILDING AREA	6,570 ± S.F.
BUILDING HT. (ALLOWED 30')	30'
FLOOR AREA RATIO (MAX. ALLOWED 1.0)	0.26
PARKING REQUIRED	
MINIMUM (1 SPACE/300 S.F.—10%*)	22 SPACES
MAXIMUM (1 SPACE/200 S.F.)	33 SPACES
TOTAL (MINIMUM-MAXIMUM)	22 - 33 SPACES
PARKING PROVIDED	25 SPACES
* 10% PARKING REDUCTION ALLOWED WHEN WITHIN 200' OF TRANSIT ROUTE	
BICYCLE PARKING REQUIRED/PROVIDED	
SHORT TERM	2 SPACES
LONG TERM (IN BUILDING)	2 SPACES

**IMPERVIOUS AREA:**

EXISTING IMPERVIOUS AREA	4,788± S.F.
PROPOSED IMPERVIOUS AREA	15,531± S.F.
TOTAL	15,531± S.F.

**LANDSCAPE DATA:**

V.I.A.	7,890± S.F.
I.L.A. REQUIRED (7.5% V.U.A.)	592 S.F.
I.L.A. PROVIDED	1,474± S.F.

**TREE CANOPY DATA:**

GROSS SITE AREA	25,885± S.F.
TREE CANOPY CATEGORY	CLASS C
EXISTING TREE CANOPY	4,934± S.F.
PROPOSED TO BE PRESERVED	0
REQUIRED/PROPOSED TREE CANOPY	5,177± S.F. (20%)

\*TREE CANOPY DEPICTED ON PLAN PER MSD LOGIC MAPPING, AERIAL PHOTO OR FIELD SURVEY. TREE CANOPY CALCULATIONS BASED UPON TREE AREAS SHOWN.

**WAIVER REQUEST:**  
A WAIVER OF 10.2.4. OF THE LDC IS REQUESTED TO REDUCE THE PERMETER BUFFER REQUIRED ALONG THE SOUTH PROPERTY LINE FROM 35' TO 20'.

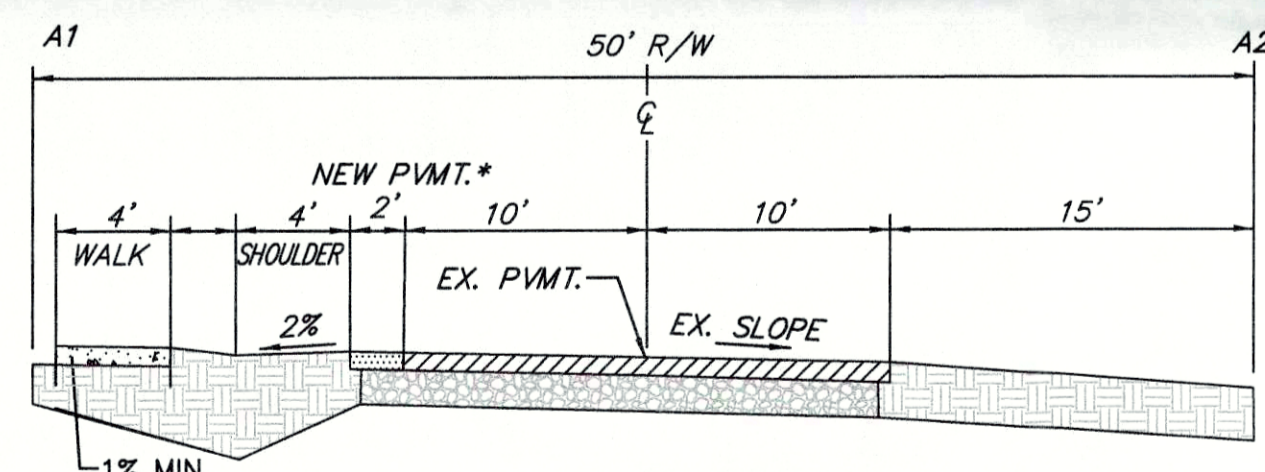

**ROAD SECTION A**  
NO SCALE  
\*SEE PUBLIC WORKS NOTE #10

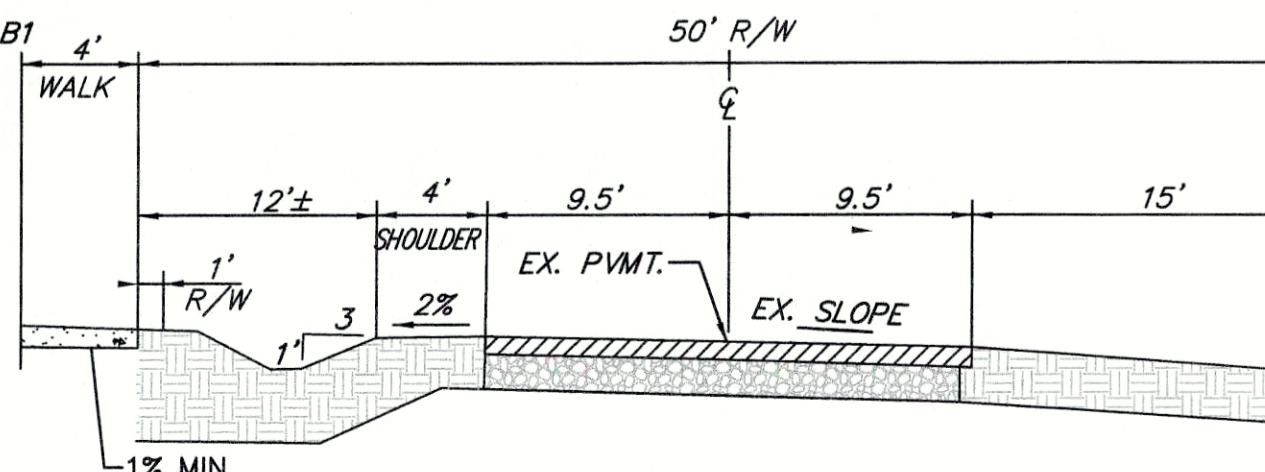

**ROAD SECTION B**  
NO SCALE

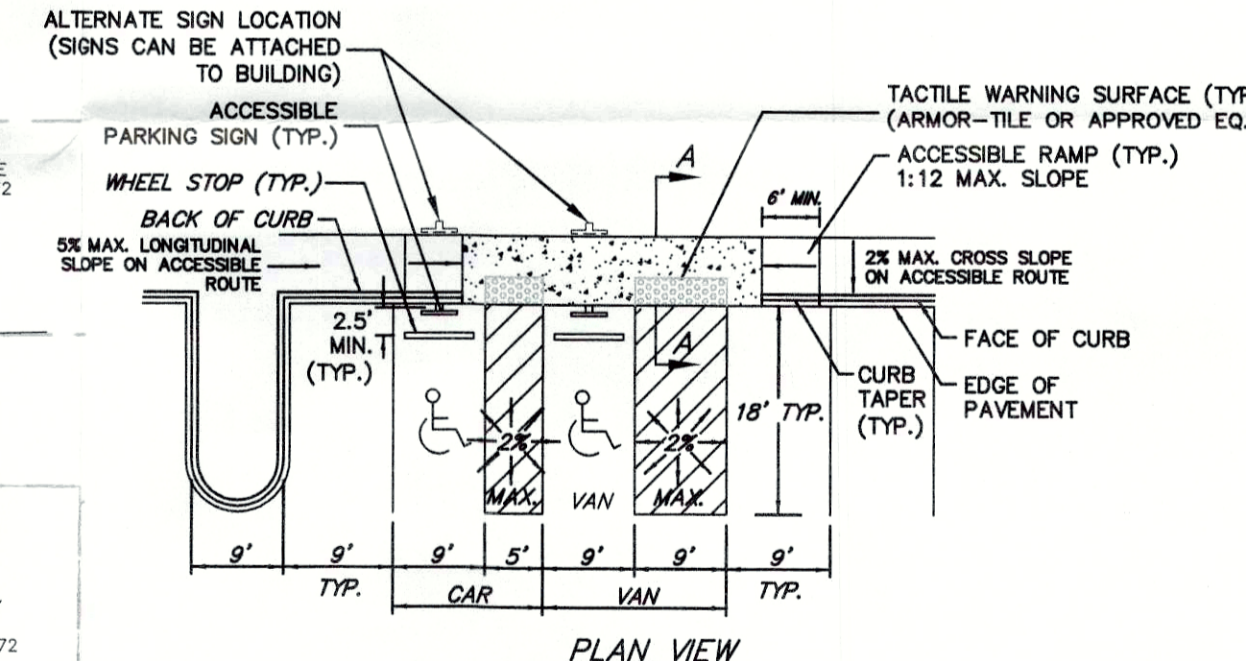

**TYPICAL ACCESSIBLE PARKING SPACES**  
NO SCALE

RECEIVED  
FEB 17 2020  
PLANNING &  
DESIGN SERVICES

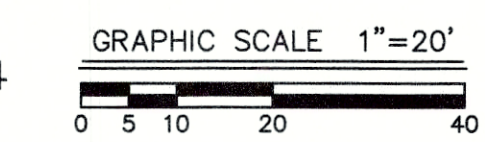

CASE # 19-ZONE-0094,  
# 19-ZONEPA-0084  
MSD WM # 12077

**MINDEL SCOTT**  
ENGINEERING & SURVEYING & PLANNING & LANDSCAPE ARCHITECTURE  
5151 Jefferson Blvd. Louisville, KY 40219  
502-465-1508 | mindelscott.com

**DEVELOPER**  
4700 WESTPORT LLC  
201 MOSER ROAD, STE C  
LOUISVILLE, KY 40223

**OWNER**  
ESTATE OF EVELYN A. KAELIN  
802 HUDDERSFIELD CT  
LOUISVILLE, KY 40222

**DETAILED DISTRICT DEVELOPMENT PLAN**  
**WESTPORT ROAD RETAIL**  
4700 WESTPORT RD & 919 & 917 FOUNTAIN AVE  
LOUISVILLE, KY 40222  
TAX BLOCK 351, LOT 31, 32, & 34  
DEED BOOK 683, PAGE 65 &  
DEED BOOK 7069, PAGE 288

Vertical Scale:	N/A
Horizontal Scale:	1"=20'
Date:	12/16/2019
Job Number:	3624
Sheet	1