

DOOR / HARDWARE SCHEDULE

MARK	TYPE	WIDTH	HEIGHT	MATERIAL	FRAME TYPE	HARDWARE	REMARKS
101-1	D1	3'-4"	6'-8"	SOLID WOOD	WOOD	SCHLAGE NES 99B716 BRASS PRIVACY POCKET DOOR PULL - AGED BRONZE	POCKET DOOR
101-2	D3	4'-10"	6'-8"	SOLID WOOD	WOOD	SCHLAGE PLYMOUTH DUMMY KNOB - AGED BRONZE	BI-FOLDING DOORS
101-3	D2	3'-0"	7'-0"	WOOD CLAD & GLASS	WOOD CLAD	PER DOOR MANUFACTURER - COORDINATE W/ARCHITECT	
102-1	D1	2'-8"	6'-8"	SOLID WOOD	WOOD	SCHLAGE PLYMOUTH PRIVACY KNOB - AGED BRONZE	

DOOR TYPES

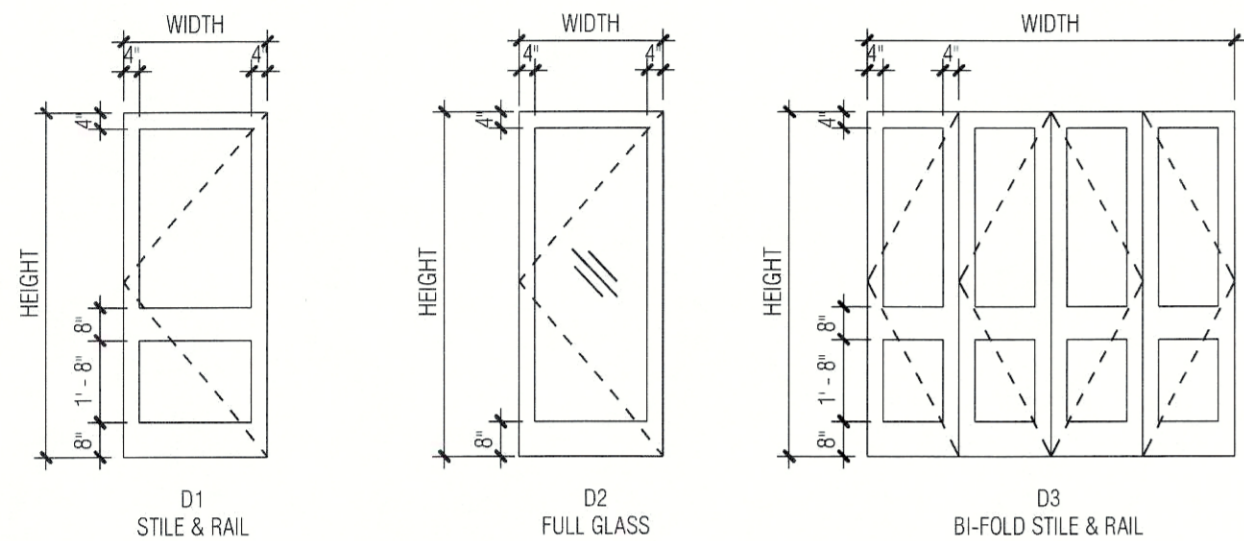

WINDOW TYPES

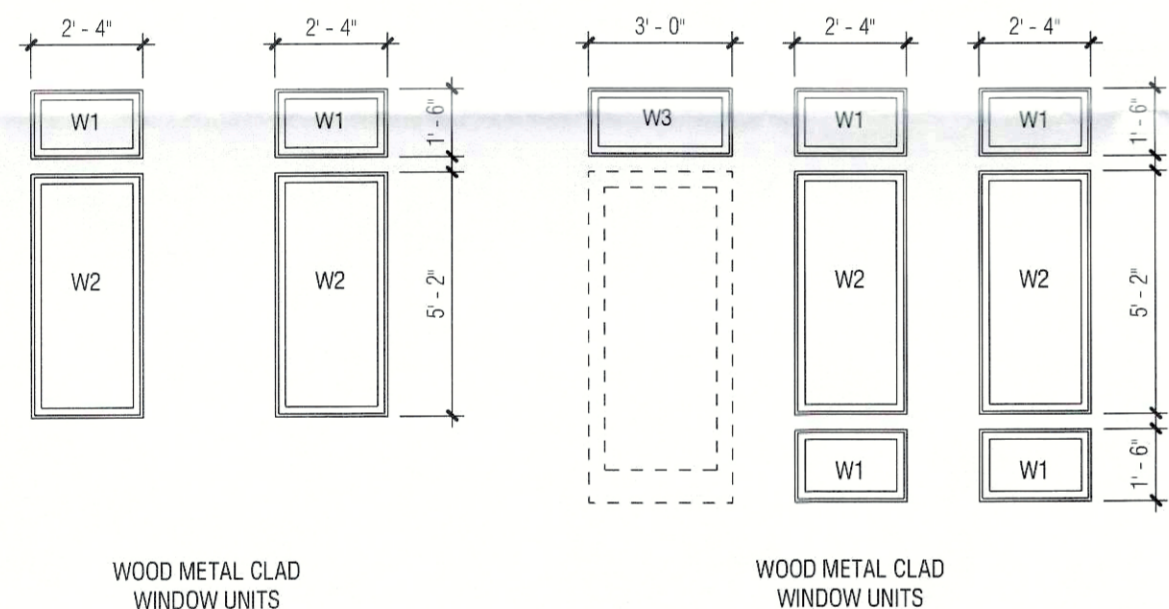

DEMOLITION PLAN

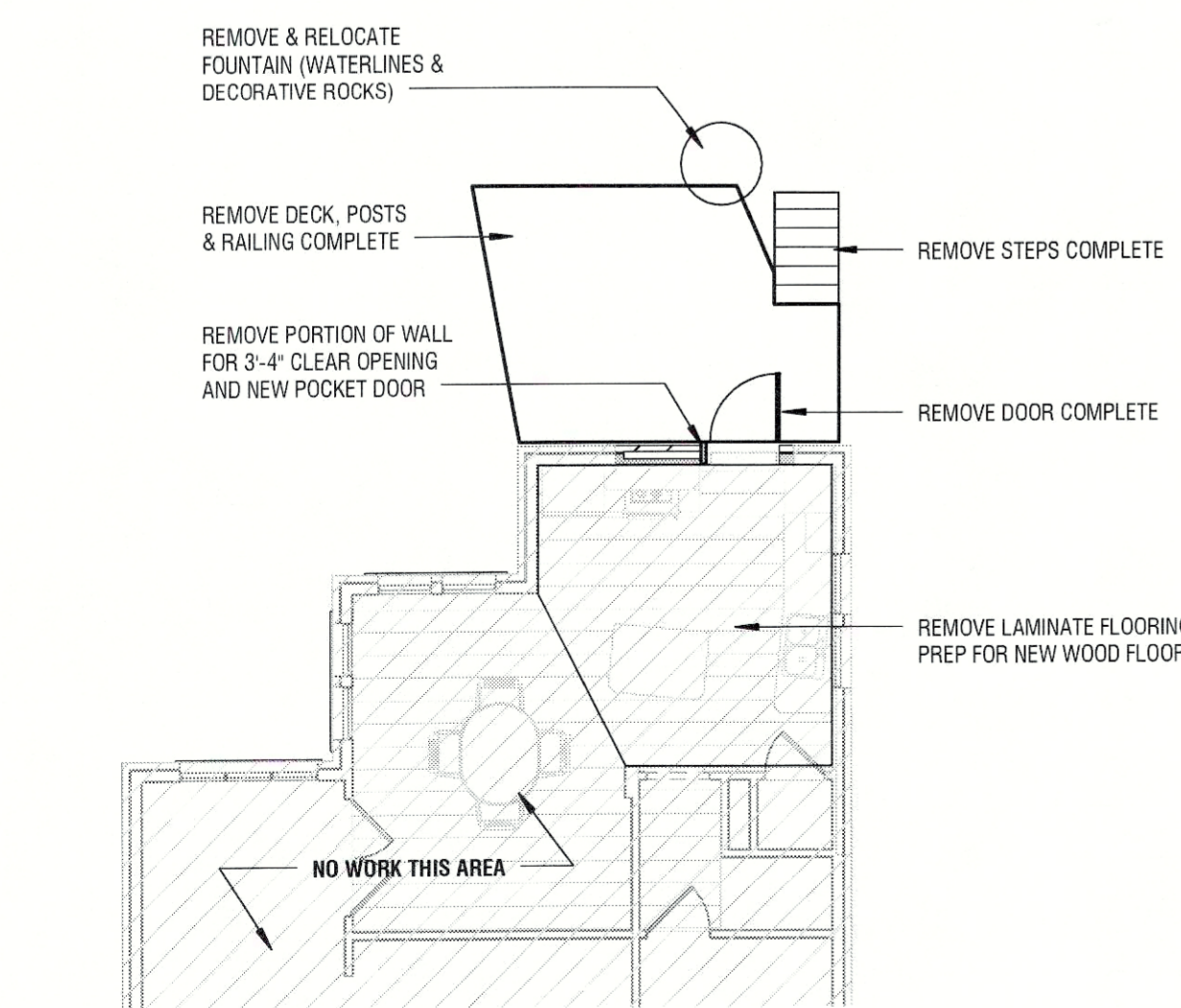

4 DEMOLITION PLAN
1/8" = 1'-0"

SITE PLAN

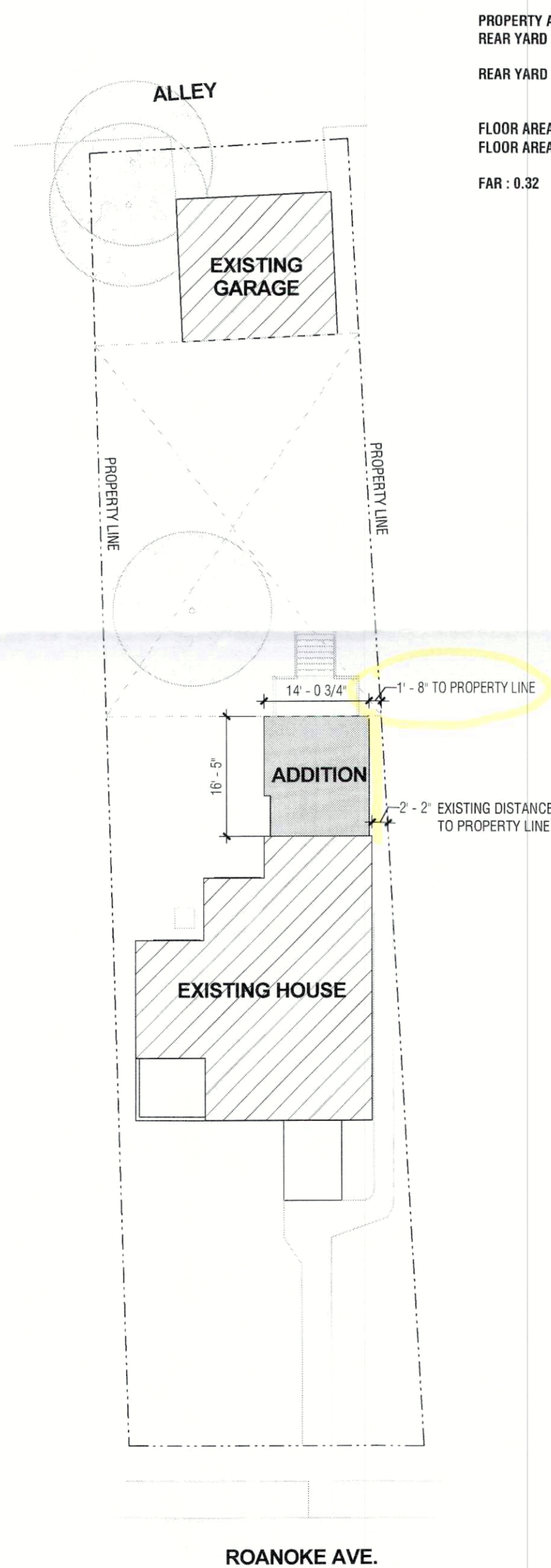

PROPERTY AREA : 6,443 SF
REAR YARD : 2,438 SF
REAR YARD : 37.7%
FLOOR AREA (EXISTING HOUSE) : 1,832 SF
FLOOR AREA (ADDITION) : 225 SF
FAR : 0.32

2 SITE PLAN
1/16" = 1'-0"

SYMBOLS LEGEND

- 1 - - - - COLUMN LINE/GRID INDICATOR
- Name Elevation BENCHMARK/FLOOR ELEVATION SYMBOL
- NORTH ARROW
- X XXX X WALL/BUILDING ELEVATION SYMBOL
- A10 A300 SIM BUILDING SECTION SYMBOL
- A10 A300 SIM WALL SECTION/DETAIL SECTION SYMBOL
- 1 SIM A101 DETAIL REFERENCE SYMBOL
- REVISION INDICATOR
- XXX TEXTNOTE SYMBOL
- EL 10'-0" FLOOR SLAB ELEVATION
- 20 R @ 7 1/2" STAIR TAG
- DIP CONCRETE, 10" FLOOR TAG
- EL 10'-0" SPOT ELEVATION SYMBOL
- ABCDEFGHIJ ROOM TAG SYMBOLS
- 101 PARTITION TYPE SYMBOL
- 101 DOOR SYMBOL
- 11 WINDOW SYMBOL
- 11 1'-0" A.F.F. CEILING FINISH & HEIGHT SYMBOL

PROJECT VICINITY MAP

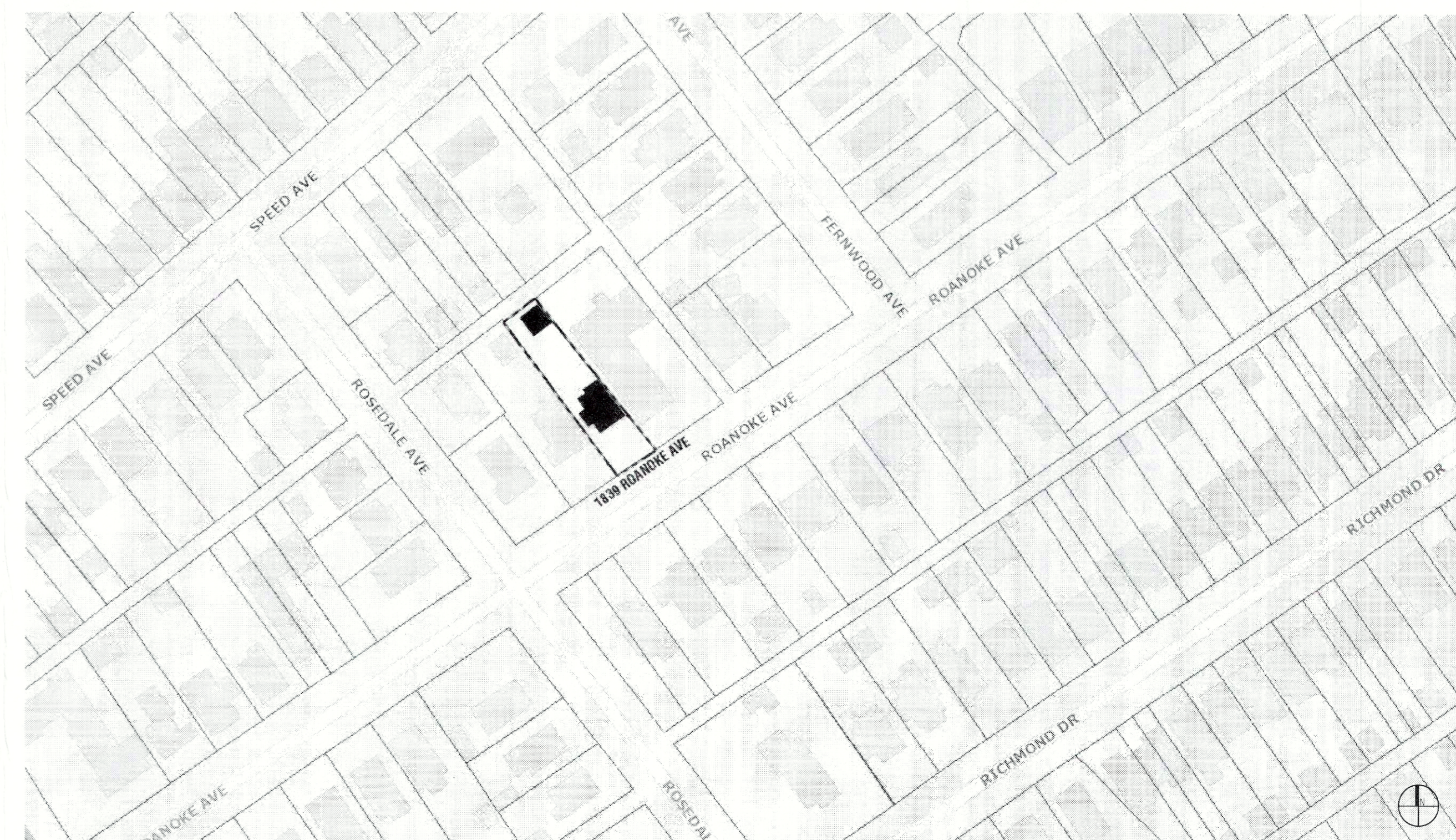

DRAWING INDEX

NO.	SHEET NAME
G1	GENERAL INFORMATION
A1	FLOOR PLANS & INTERIOR ELEVATIONS
A2	EXTERIOR ELEVATIONS & BUILDING SECTION
A3	FOUNDATION PLAN, RCP & ROOF PLAN

GENERAL NOTES

- DO NOT SCALE DRAWINGS. WRITTEN DIMENSIONS TAKE PRECEDENCE.
- DRAWINGS HAVE BEEN PREPARED ON AN ORIGINAL SHEET SIZE OF 24" X 36".
- DIMENSIONS SHOWN INDICATE FACE OF (F.O.) CONCRETE, F.O. MASONRY, F.O. SHEATHING, F.O. FINISH (INTERIOR), OR CENTERLINE OF COLUMN GRIDLINE, U.N.O.
- INFORMATION REGARDING EXISTING CONDITIONS USED TO PREPARE THESE DRAWINGS HAVE BEEN PROVIDED BY OTHERS. CONTRACTOR TO FIELD VERIFY EXISTING CONDITIONS PRIOR TO COMMENCING CONSTRUCTION. PROVIDE WRITTEN NOTIFICATION TO THE ARCHITECT OF ANY DISCREPANCIES BETWEEN EXISTING CONDITIONS AND THE DRAWINGS. THE ARCHITECT WILL ISSUE A WRITTEN DIRECTIVE IF FURTHER CLARIFICATION IS REQUIRED.
- CONTRACTOR TO FIELD VERIFY ALL DIMENSIONS, DATUM, LEVELS AND CONDITIONS PERTAINING TO THE WORK PRIOR TO COMMENCING CONSTRUCTION. PROVIDE WRITTEN NOTIFICATION TO THE ARCHITECT OF ANY DISCREPANCIES WITH THE DOCUMENTS. THE ARCHITECT WILL ISSUE A WRITTEN DIRECTIVE IF FURTHER CLARIFICATION IS REQUIRED.
- THESE DRAWINGS ARE THE EXCLUSIVE PROPERTY OF LMS DESIGN AND HAVE BEEN PREPARED FOR USE IN THE EXECUTION OF THE ENCLOSED PROJECT. USE OR REPRODUCTION FOR ANY OTHER PURPOSE WITHOUT THE WRITTEN PERMISSION OF IS PROHIBITED.

LDC SUMMARY

GENERAL INFORMATION	
CITY:	LOUISVILLE
ZIP CODE:	40206
PARCEL ID:	076J00880000
CURRENT SUBDIVISION:	FOREST PARK SUBDIVISION AND NITTA YUMA
ZONING:	FSB
FORM DISTRICT:	TRADITIONAL NEIGHBORHOOD
OVERLAY DISTRICT:	NO
HISTORIC PRESERVATION:	NO
F.A.R. ALLOWED:	0.5
REAR YARD PERMITTED:	> 30%

LMS DESIGN
ARCHITECTURAL SERVICES

PO BOX 6181
LOUISVILLE KY 40206
502.581.1111
lmsdesign@lmsdesign.com

PERMIT SET

CONSULTANT SEAL

RECEIVED
NOV 21 2016
PLANNING &
DESIGN SERVICES

PROJECT
ROANOKE RESIDENCE

1839 ROANOKE AVE LOUISVILLE KY
40205

PROJECT NO. 1608

SCALE DATE 11/01/2016

REVISION NO.

SCALE

SHEET TITLE
GENERAL
INFORMATION

SHEET NO.

G1