



211 WEST MUHAMMAD ALI BLVD. LOUISVILLE, KY 40202 (502) 574-3817 FAX (502) 574-4029
WWW.LOUISVILLEKY.GOV/PARC

Tiffany Smith
Director

June 2, 2015

MEMORANDUM

To: Marian Salmon
Director, Purchasing

From: Tiffany Smith *TSmith*
Director, Parking Authority of River City

Re: POM, Inc. Sole Source Request

I hereby request that POM, Inc. be designated as a Sole Source of parking meter parts and equipment for the fiscal year 2016.

This vendor provides a specialized product or service which is limited in availability since it utilizes proprietary technology. Additionally, the vendor is the only supplier within the geographic area which can meet the needs of the Parking Authority. As such, I believe that Sole Source status should be granted to this vendor. Please find the additional documentation attached as support for the "Sole Source" designation.

Thank you.

ts/jh



GREG FISCHER
MAYOR

AGREEMENT FOR SOLE SOURCE PURCHASE

THIS CONTRACT, made and entered into by and between the **LOUISVILLE/JEFFERSON COUNTY METRO GOVERNMENT**, by and through its **PARKING AUTHORITY OF RIVER CITY**, herein referred to as "**METRO GOVERNMENT**", and **POM, INCORPORATED** , with offices located at 200 South Elmira Avenue, Russelville, Arkansas 72811, herein referred to as "**CONTRACTOR**",

WITNESSETH:

WHEREAS, the Metro Government wishes to purchase parking meter replacement parts; and

WHEREAS, the Contractor has been determined by the Metro Government to be a sole source to provide same,

NOW, THEREFORE, it is agreed by and between the parties hereto as follows:

I. SCOPE OF SERVICES

A. Contractor shall, at the request of the Metro Government, provide goods under the terms of this Agreement.

B. The services of Contractor shall include but not be limited to the following:

1. Parking meter replacement parts as described on Attachment A attached hereto and fully incorporated herein.

II. FEES AND COMPENSATION

A. The Metro Government shall pay Contractor for goods as priced on Attachment A. Total compensation payable to Contractor for services rendered pursuant to this Agreement shall not exceed **SEVENTY-FIVE THOUSAND DOLLARS (\$75,000.00)**.

B. Payment shall be made pursuant to Attachment A.

C. The Metro Government shall not reimburse out of pocket expenses under this Agreement.

III. DURATION

A. This Agreement shall begin July 1, 2015 and shall continue through and including June 30, 2016.

B. This Agreement may be terminated by submitting thirty (30) days' written notice to the non-terminating party of such intent to terminate. This Agreement may also be terminated by any party, without notice to the non-terminating party, because of fraud, misappropriation, embezzlement or malfeasance or a party's failure to perform the duties required under this Agreement. A waiver by either party of a breach of this Agreement shall not operate or be construed as a waiver of any subsequent breach.

C. In the event of termination, payment for services complete up to and including date of termination shall be based upon work completed at the rates identified in this Agreement.

IV. RECORDS-AUDIT

Contractor shall maintain during the course of the work, and retain not less than five years from the date of final payment on the contract, complete and accurate records of all of Contractor's costs which are chargeable to the Metro Government under this Agreement; and the Metro Government shall have the right, at any reasonable time, to inspect and audit those records by authorized representatives of its own or of any public accounting firm selected by it. The records to be thus maintained and retained by Contractor shall include (without limitation): (a) payroll records accounting for total time distribution of Contractor's employees working full or part time on the work (to permit tracing to payrolls and related tax returns), as well as canceled payroll checks, or signed receipts for payroll payments in cash; (b) invoices for purchases receiving and issuing

documents, and all the other unit inventory records for Contractor's stores stock or capital items; and (c) paid invoices and canceled checks for materials purchased and for subcontractors' and any other third parties' charges.

V. INSURANCE REQUIREMENTS

Insurance coverage shall be required of Contractor in accordance with Schedule B attached hereto.

VI. HOLD HARMLESS AND INDEMNIFICATION CLAUSE

The Contractor shall indemnify, hold harmless, and defend Metro Government, its elected and appointed officials, employees, agents and successors in interest from all claims, damages, losses and expenses including attorneys' fees, arising out of or resulting, directly or indirectly, from the Contractor's (or Contractor's Subcontractors, if any) performance or breach of the contract provided that such claim, damage, loss, or expense is: (1) attributable to personal injury, bodily injury, sickness, death, or to injury to or destruction of property, including the loss of use resulting therefrom, or breach of contract, and (2) not caused by the negligent act or omission or willful misconduct of Metro Government or its elected and appointed officials and employees acting within the scope of their employment. This Hold Harmless and Indemnification Clause shall in no way be limited by any financial responsibility or insurance requirements and shall survive the termination of this Contract.

VII. REPORTING OF INCOME

The compensation payable under this Agreement may be subject to federal, state and local taxation. Regulations of the Internal Revenue Service require the Metro Government to report all amounts in excess of \$600.00 paid to non-corporate contractors. Contractor agrees to furnish the Metro Government with its taxpayer identification number (TIN) prior to the effective date of this Agreement. Contractor further agrees to provide

such other information to the Metro Government as may be required by the IRS or the State Department of Revenue.

VIII. GOVERNING LAW

This Agreement shall be governed by and construed in accordance with the laws of the State of Kentucky. In the event of any proceedings regarding this Agreement, the Parties agree that the venue shall be the state courts of Kentucky or the U.S. District Court for the Western District of Kentucky, Louisville Division. All parties expressly consent to personal jurisdiction and venue in such Court for the limited and sole purpose of proceedings relating to this Agreement or any rights or obligations arising thereunder. Service of process may be accomplished by following the procedures prescribed by law.

IX. AUTHORITY

The Contractor, by execution of this Agreement, does hereby warrant and represent that he is qualified to do business in the State of Kentucky, has full right, power and authority to enter into this Agreement.

X. CONFLICTS OF INTEREST

Pursuant to KRS 45A.455:

(1) It shall be a breach of ethical standards for any employee with procurement authority to participate directly in any proceeding or application; request for ruling or other determination; claim or controversy; or other particular matter pertaining to any contract, or subcontract, and any solicitation or proposal therefor, in which to his knowledge:

(a) He, or any member of his immediate family has a financial interest therein;

or

(b) A business or organization in which he or any member of his immediate family has a financial interest as an officer, director, trustee, partner, or employee, is a party; or

(c) Any other person, business, or organization with whom he or any member of his immediate family is negotiating or has an arrangement concerning prospective employment is a party. Direct or indirect participation shall include but not be limited to involvement through decision, approval, disapproval, recommendation, preparation of any part of a purchase request, influencing the content of any specification or purchase standard, rendering of advice, investigation, auditing, or in any other advisory capacity.

(2) It shall be a breach of ethical standards for any person to offer, give, or agree to give any employee or former employee, or for any employee or former employee to solicit, demand, accept, or agree to accept from another person, a gratuity or an offer of employment, in connection with any decision, approval, disapproval, recommendation, preparation of any part of a purchase request, influencing the content of any specification or purchase standard, rendering of advice, investigation, auditing, or in any other advisory capacity in any proceeding or application, request for ruling or other determination, claim or controversy, or other particular matter, pertaining to any contract or subcontract and any solicitation or proposal therefor.

(3) It is a breach of ethical standards for any payment, gratuity, or offer of employment to be made by or on behalf of a subcontractor under a contract to the prime contractor or higher tier subcontractor or any person associated therewith, as an inducement for the award of a subcontract or order.

(4) The prohibition against conflicts of interest and gratuities and kickbacks shall be conspicuously set forth in every local public agency written contract and solicitation therefor.

(5) It shall be a breach of ethical standards for any public employee or former employee knowingly to use confidential information for his actual or anticipated personal gain, or the actual or anticipated personal gain of any other person.

XII. ENTIRE AGREEMENT

This Agreement constitutes the entire agreement and understanding of the parties with respect to the subject matter set forth herein and this Agreement supersedes any and all prior and contemporaneous oral or written agreements or understandings between the parties relative thereto. No representation, promise, inducement, or statement of intention has been made by the parties that is not embodied in this Agreement. This Agreement cannot be amended, modified, or supplemented in any respect except by a subsequent written agreement duly executed by all of the parties hereto. In the event of a conflict between the terms of this Agreement and the terms in any of the Attachments, this Agreement shall govern.

XIII. SUCCESSORS

This Agreement shall be binding upon and inure to the benefit of the parties hereto and their respective heirs, successors and assigns.

XIV. SEVERABILITY

If any court of competent jurisdiction holds any provision of this Agreement unenforceable, such provision shall be modified to the extent required to make it enforceable, consistent with the spirit and intent of this Agreement. If such a provision cannot be so modified, the provision shall be deemed separable from the remaining provisions of this Agreement and shall not affect any other provision hereunder.

XV. COUNTERPARTS

This Agreement may be executed in counterparts, in which case each executed counterpart shall be deemed an original and all executed counterparts shall constitute one and the same instrument.

XVI. CALCULATION OF TIME

Unless otherwise indicated, when the performance or doing of any act, duty, matter, or payment is required hereunder and a period of time or duration for the fulfillment of doing thereof is prescribed and is fixed herein, the time shall be computed so as to exclude the first and include the last day of the prescribed or fixed period of time. For example, if on January 1, Contractor is directed to take action within ten (10) calendar days, the action must be completed no later than midnight, January 11.

XVII. CAPTIONS

The captions and headings of this Agreement are for convenience and reference purposes only and shall not affect in any way the meaning and interpretation of any provisions of this Agreement.

XVIII. VIOLATIONS OF AND COMPLIANCE WITH KENTUCKY LAWS

The Contractor shall reveal any final determination of a violation by the Contractor or subcontractor within the previous five (5) year period pursuant to KRS Chapters 136, 139, 141, 337, 338, 341 and 342 that apply to the Contractor or subcontractor. The Contractor shall be in continuous compliance with the provisions of KRS Chapters 136, 139, 141, 337, 338, 341 and 342 that apply to the Contractor or subcontractor for the duration of the contract.

WITNESS the agreement of the parties hereto by their signatures affixed hereon.

APPROVED AS TO FORM AND LEGALITY:

LOUISVILLE/JEFFERSON COUNTY METRO GOVERNMENT

Paul J. O'Connell
MICHAEL J. O'CONNELL
JEFFERSON COUNTY ATTORNEY

Marian Salmon
MARIAN SALMON, DIRECTOR, PURCHASING DEPARTMENT

Date: 9-4-15

Date: 9/10/15

PARKING AUTHORITY OF RIVER CITY

Tiffany Smith
TIFFANY SMITH, DIRECTOR

Date: 9/8/15

POM, INCORPORATED

By: *Amy Adkison* Amy Adkison

Title: Regional Sales Manager

Date: 9/4/15

Taxpayer Identification No., (TIN): _____

Louisville/Jefferson County Revenue Commission Account No.: _____

ATTACHMENT A

All E or Available Duncan HOUSING PARTS AND ACCESSORIES COMBINED, Sorted in alphabetical order, effective June 1, 2014. Re-sort as you wish. (* means it must be configured with this part number as the base).

Duncan Part			
Part No.	No.	Description	Price Ea.
103-215		Axle	\$ 26.31
101-200		Base flange, die cast zinc, for 2" ID (2-1/2"OD) pipe, unpainted	\$ 15.84
101-201		Base flange, die cast zinc, for 2-1/2" ID (3"OD) pipe,	\$ 17.85
102-935		Base flange, stamped aluminum, unpainted, for 2" ID (2-1/2" OD) pipe	\$ 9.00
100-399		Blank number plate	\$ 0.74
101-423-001		Bolt, Carriage	\$ 0.18
103-223		Bolt, Hex head	\$ 0.25
103-226		Bolt, Hex head	\$ 0.10
100-562		Bolt, twin adapter, 1/2-13x4 Grade 5	\$ 0.68
108-701		Bracket, lock slide	\$ 0.96
108-791	3308	Bumper, 95	\$ 1.43
100-609-002		Can Stop	\$ 6.00
103-375		Cart Weldment	\$ 508.00
108-739		Changematic lock for 95 vault door	\$ 25.00
101-574-001		Changematic lock for Duncan 60, w/nut Specify series	\$ 24.10
108-293		Changematic lock for Duncan 65 and 76, w/screw	\$ 20.00
108-687		Changematic lock for Duncan 76 duplex	\$ 22.50
101-575-003		Changematic lock for E Vault doors	\$ 23.78
101-574		Changematic lock for E zinc or iron Mech housing, specify series 1K-, 2K- Etc.	\$ 20.55
101-579		Changematic reset tool, specify 1K-, 2K-, etc.	\$ 9.05
103-290		Chute for twin converter	\$ 8.40
103-291		Chute top for twin converter	\$ 3.73
102-959		Coin box bracket, lg or Magnum coin box	\$ 7.30
102-959-001		Coin box bracket, lg or Magnum, reinforced	\$ 9.25
108-365		Coin box lock, Duo, specify series	\$ 9.00
108-780	73373	Coin box retainer assy, 95	\$ 7.00
108-006*		Coin box, Cicolac, expanded, w/E-lock	\$ 38.82
108-006*		Coin box, Cicolac, expanded, w/L series lock	\$ 38.82
108-007*	69201-101	Coin box, Cicolac, for Duncan duplexes specify code, w/E-lock	\$ 38.82
108-007*	69201-101	Coin box, Cicolac, for Duncan duplexes specify code, w/L series lock	\$ 38.82
108-914*		Coin box, Cicolac, Magnum size, specify lock code	\$ 40.00
108-008*	69200-101	Coin box, Cicolac, standard size, with E-lock specify series	\$ 35.00
108-008*	69200-101	Coin box, Cicolac, standard size, with L series lock, specify series	\$ 35.00
108-465		Collection Canister with Collection Head Assembly, sp	\$ 677.73
108-545		Collection Canister, with Hasp, lid, and handles, 8x11x	\$ 410.12
108-330		Collection head assembly	\$ 350.00
108-330		Collection Head Assembly, specify code	\$ 350.00

102-997-001-	Converter, Twin, for Duncan zinc top, powder	\$	59.00
108-311-001	Decal for enforcement plate, specify verbiage	\$	0.50
108-631	2395 Dome gasket (fits Duncan zinc tops)	\$	0.90
108-825-001	Dome Gasket thick ¼" for 95 Iron mech housing w/insert	\$	2.00
108-309	79019 Dome Retainer, E or Duncan iron top	\$	6.43
102-652	2041-3 Dome window, Lexan, rounded	\$	2.28
108-777	73371-1 Door bracket assy left, 95	\$	2.20
108-775	73371-2 Door bracket assy right, 95	\$	2.20
108-255	3331-2 Door bracket screw, 95	\$	0.10
108-771	73372 Door link and bracket assy, 95	\$	7.64
108-482-POW	73345-10 Door, 95, with bushing, powder painted	\$	19.30
108-906-003- POW	Door, Magnum iron vault, powder painted, machined for National Lock (or specify if other lock)	\$	40.00
100-424	Drive screw #0x1/4	\$	0.16
108-788-POW	90405 powder painted	\$	65.10
108-405	3016-2 E-lock barrel for mech housings	\$	3.00
108-076	2902-3 E-lock for coin box, specify series	\$	13.30
108-574	E-lock for vault doors, specify series	\$	16.67
108-393	75030 E-lock plug for coin box, code?	\$	10.10
108-412-001	3381-1 E-lock plug shield for vault	\$	0.25
108-427	63022 E-lock plug w/square, specify series	\$	10.75
108-425	63325 E-lock plug, w/threads	\$	10.50
108-311	Enforcement plate with decal, specify verbiage	\$	1.29
100-244	E-ring	\$	0.45
103-208	E-ring	\$	0.12
108-412	3381 Fixed shield for vault	\$	0.24
108-404	Flat washer	\$	0.98
103-224	Flat Washer	\$	0.14
103-310	Gasket, drain plate	\$	0.59
108-657	Gasket, window, formed	\$	1.02
108-825-001	9018 Gasket, window, iron 95	\$	2.10
103-063	Gripper wedge (3 required)	\$	1.50
103-064	Gripper wedge assy w/nut, 2" ID pipe	\$	6.00
103-284	Gripper wedge assy w/nut, 2-1/2" pipe	\$	7.52
103-065	Gripper wedge kit w/washer & grade 5 bolt	\$	6.71
100-469	Handle for tubular key	\$	15.00
108-587	2041-1 High-visibility Lexan dome (flat faced)	\$	3.06
102-962	Hinge bracket assy	\$	3.10
102-629	Hinge pivot	\$	0.66
108-783-POW	9016-2 Housing Cap, powder painted	\$	40.00
108-402-002	III. Duo key, long for vault, series?	\$	7.89
108-402	III. Duo key, short for mech housings Specify series	\$	6.53
108-850	III. Duo lock for 95 vault door	\$	22.00
108-438	Instruction decal, zinc upper housing	\$	1.28
108-438-004	Instruction decal, zinc upper housing, Insert coin	\$	0.74
108-792	3349 Instruction plate, 95	\$	1.00
103-454	Instruction, Wedge Lok	\$	\$0.00
108-300-POW	Iron dome, E, powder painted gray	\$	29.20
108-302-POW	Iron mech housing, powder painted gray	\$	64.00

100-468		Key for E top housing, specify series EX-, MM-, etc.	\$	7.78
100-384-xxx		Key for top housing, specify series in last three digits (POM, MCM, etc.)	\$	4.27
103-436		Key, Changematic, w/extension and zinc handle	\$	21.40
103-395		Key, Changematic, w/smaller style zinc handle	\$	19.84
108-379		Key, collection head, Duo L-series	\$	8.30
108-078	2302-2	Key, collection head, E series	\$	12.00
108-346		Key, E, long for vault, specify series	\$	10.78
108-078-001		Key, E, long for vault, steel	\$	11.00
108-347	62058-2	Key, E, short for mech housing, series?	\$	10.20
108-672		Key, Exercise, E style	\$	10.00
108-943		Key, Lori (Login) for zinc TP upper housing	\$	9.38
102-671		Key, Medeco, short for mech housing	\$	6.85
102-986		Key, service, National Lock, series?	\$	15.00
102-987		Key, set, National Lock, series?	\$	24.02
103-253		Key, steel tubular w/handle, long, specify series 1K, 2K, etc.	\$	33.40
103-252		Key, steel tubular w/o handle, long, specify series 1K, 2K, etc.	\$	17.30
108-879		Key, upper housing, mid-length for 95	\$	9.57
103-536		Key, vault, Lori (Login)	\$	14.46
108-287		Kit for installing customer's Duncan changelock in Model E door	\$	7.25
103-453-KIT		Kit, Wedge Lok Pipe, raw finish, boxed (add \$5 if painted and specify color)	\$	47.48
101-678		Large number plate, specify number	\$	1.50
108-406		Large nut	\$	0.43
108-698-003		Lock arm, wire form, Duo	\$	1.00
108-698-002		Lock arm, wire form, std	\$	1.00
108-584-001		Lock assembly, E, 95 vault	\$	14.50
103-540		Lock assembly, Lori (Login), with cam and collar, for zinc or iron TP vault door	\$	20.41
100-466		Lock assy for E iron or zinc mech housing (specify series EX-, MM-, etc.)	\$	20.30
108-473	9023-1	Lock barrel	\$	3.00
108-448		Lock barrel, TP vault door	\$	2.13
108-448-001	3317-Z1	Lock barrel, 95 vault door	\$	2.67
103-008		Lock barrel, Medeco, for E vault door	\$	2.09
108-485	73341	Lock bolt assy, 95	\$	1.80
108-769	3326-1	Lock bolt retainer bracket, 95	\$	2.10
108-431		Lock bolt, POM lock	\$	0.29
108-299	3002	Lock cam for Duncan Model 76	\$	0.99
108-569	3302	Lock cam, 95	\$	0.60
102-993		Lock cam, Changematic	\$	1.39
102-993-001		Lock cam, Medeco or Duo	\$	1.39
100-685		Lock cap	\$	3.68
103-012		Lock plug, Medeco, for E vault door	\$	35.68
102-998-001		Lock plug, POM, E mech housing	\$	8.37
108-770	3378	Lock retainer	\$	0.90
108-564	9024	Lock retaining pin	\$	0.05
102-992		Lock	\$	3.63

102-992-001		Lock slide for E-lock	\$	3.63
108-702		Lock slide spring, wire form	\$	0.43
108-696		Lock slide, wire form	\$	4.08
100-473		Lock washer	\$	0.20
103-225		Lock Washer	\$	0.15
108-423	3329	Lock washer, 95	\$	0.11
103-027		Lock, Illinois Duo, for E tops, series?	\$	16.10
103-026		Lock, Illinois Duo, for E vault, series?	\$	18.51
108-942		Lock, Lori (Login), for zinc TP upper housing	\$	17.25
102-670-001		Lock, Medeco, for E zinc or iron mech housings, specify series	\$	31.00
108-789	9020	Locking rod	\$	15.00
108-381		Medeco key, long for vault, series?	\$	8.60
102-488-001		Medeco lock for E vault doors, specify Series	\$	39.76
100-426		Mounting bolt 1/2-13x5 Grade 5 h.d.	\$	0.71
108-259		National vault lock, specify series	\$	40.92
100-398		Number plate, specify numbers	\$	1.27
101-424		Nut	\$	0.18
100-472		Nut 9/32-28	\$	0.39
108-430	2016	Nut, 95	\$	0.07
103-015		Nut, E-Lock, TP Vault	\$	1.50
100-436		Nut, expansion anchor	\$	1.58
100-471		Nut, large for lock	\$	0.69
101-410-001	1348	Open coin box for 95 vault	\$	5.04
101-410		Open top coin box	\$	5.04
108-926		Open top coin box, Magnum	\$	9.84
100-634		Padlock and 2 keys	\$	13.00
100-766		Padlock and 2 keys	\$	22.89
103-184		Plate, drain	\$	8.25
108-322-POW		Plug, iron twin adapter, powder painted	\$	3.50
103-189		Plug, rubber	\$	0.13
108-420		POM lock barrel, mech housing	\$	2.00
108-474	9022	Primary lock shield, mech housing	\$	2.60
100-840*		Quad mounting adapter assy, 2"	\$	120.00
100-841*		Quad mounting adapter assy, 2"-1/2"	\$	130.00
108-111	3499	Rate Plate	\$	\$2.04
101-334		Retainer washer	\$	0.16
100-639		Return spring, X wheel	\$	0.69
100-638		Return spring, Y wheel	\$	0.72
100-684		Safeguard Coin box Door, Specify Code	\$	18.76
100-678		Safeguard coin box for E or Duncan, specify code	\$	37.00
100-677		Safeguard coin box w/o door	\$	23.62
102-895		Screw	\$	0.14
108-081-001	1037-5	Screw	\$	0.13
108-310		Screw	\$	0.88
108-644		Screw #8-15x1, Phillips flat head	\$	0.05
108-398		Screw 10-32x1"	\$	0.19
108-312-002		Screw 5/16x1-1/4" socket head cap screw	\$	0.32
100-368	1903	Screw 6-32x3/16	\$	0.19
108-432	3023	Screw, 12-28 x 3/16 truss head	\$	1.80
100-637		Screw, 4-40x3/8, flat head	\$	0.13
108-312	9025-9	Screw, 5/16" housing attachment	\$	0.16

100-717	Screw, coin door bracket	\$	0.24
108-041	Screw, Drive #2-3/16	\$	0.04
108-429	1030-5 Screw, truss head phillips	\$	0.05
108-374	5091-P Serial number decal	\$	0.63
101-678-006	1705 Serial number plate (specify #)	\$	1.44
108-538	9027-1 Set screw	\$	0.35
108-538	9027-1 Set screw	\$	0.35
100-569	Set screw 1/4-20x5/8	\$	0.60
102-994	Shoulder screw for E-lock in vault	\$	0.80
103-017	Shoulder screw for E-lock in vault	\$	0.80
103-068	Shoulder screw for Medeco, Duo or Changematic vault locks	\$	0.80
102-680	Slide, Hinge	\$	1.06
102-680-001	Slide, hinge, Magnum	\$	1.06
101-678-001	Special Large Number plate, specify number	\$	1.32
108-411	3327 Spin shield	\$	0.22
100-435	Steel wedge assy, 2" w/nut	\$	3.70
100-438	Steel wedge assy, 2-1/2" w/o nut	\$	5.00
102-178	Steel wedge assy, 2-1/8" ID pipe	\$	5.38
100-437	Steel wedge, 2" (3 required)	\$	0.57
103-458	Tool kit, Wedge Lok, installation/removal	\$	110.00
100-556*	Twin adapter assembly, aluminum, for 2" ID pipe, set-screw mounting type, specify type of meter to be mounted, unpainted		\$38.99
108-326*	69116-003 Twin adapter assy, iron, specify type of meter and wedge assy style	\$	74.00
108-325	3048 Twin adapter bolt 1/2-13x4	\$	2.52
108-323	4297 Twin adapter nut	\$	0.52
108-322	6070 Twin adapter plug	\$	4.33
108-324-POW	6073 Twin adapter, iron, painted, no hardware	\$	46.30
108-816	79001-1 Upper housing lock assy (specify combination)	\$	31.00
108-786-POW	9017-6 Upper housing, 95 Iron, powder painted	\$	72.30
103-051-POW	Vault door, E iron, powder painted gray	\$	26.00
102-967-POW	Vault door, E zinc, powder painted gray	\$	21.99
102-754-001-POW	Vault, E iron, without door, powder painted gray, machined for #10-32 screws (will fit Duncan zinc mech top)	\$	73.00
102-754-POW	Vault, E iron, without door, powder painted gray, machined for 5/16-24 screws (will fit Duncan iron mech top)	\$	75.20
102-965-POW	Vault, E zinc, w/o door, powder painted	\$	67.80
108-905-POW	Vault, Magnum iron, powder painted	\$	120.00
108-346	62058-4 VIP key with handle (combination?)	\$	8.01
101-415	Wall mounting bracket	\$	97.00
108-256	Washer	\$	0.07
108-307-001	Washer	\$	0.29
100-434	Washer, 1/2" flat	\$	0.42
102-217	Washer, Flat	\$	0.35
103-228	Washer, Lock	\$	0.10
103-450	Wedge Lok Assy		\$89.00
103-452	Wedge, Wedge Lok	\$	3.09
100-602	Wheel	\$	82.15

100-687	X Latch wheel	\$	0.94
100-686	Y latch wheel	\$	1.01
108-314-POW	Zinc dome housing, powder painted gray	\$	18.64
108-316-POW	Zinc mechanism housing, powder painted gray (for EX, Changematic, Duo or E-lock)	\$	48.60
108-316-001-POW	Zinc mechanism housing, powder painted gray (for Medeco lock).	\$	49.30

COIN CART ASSEMBLY

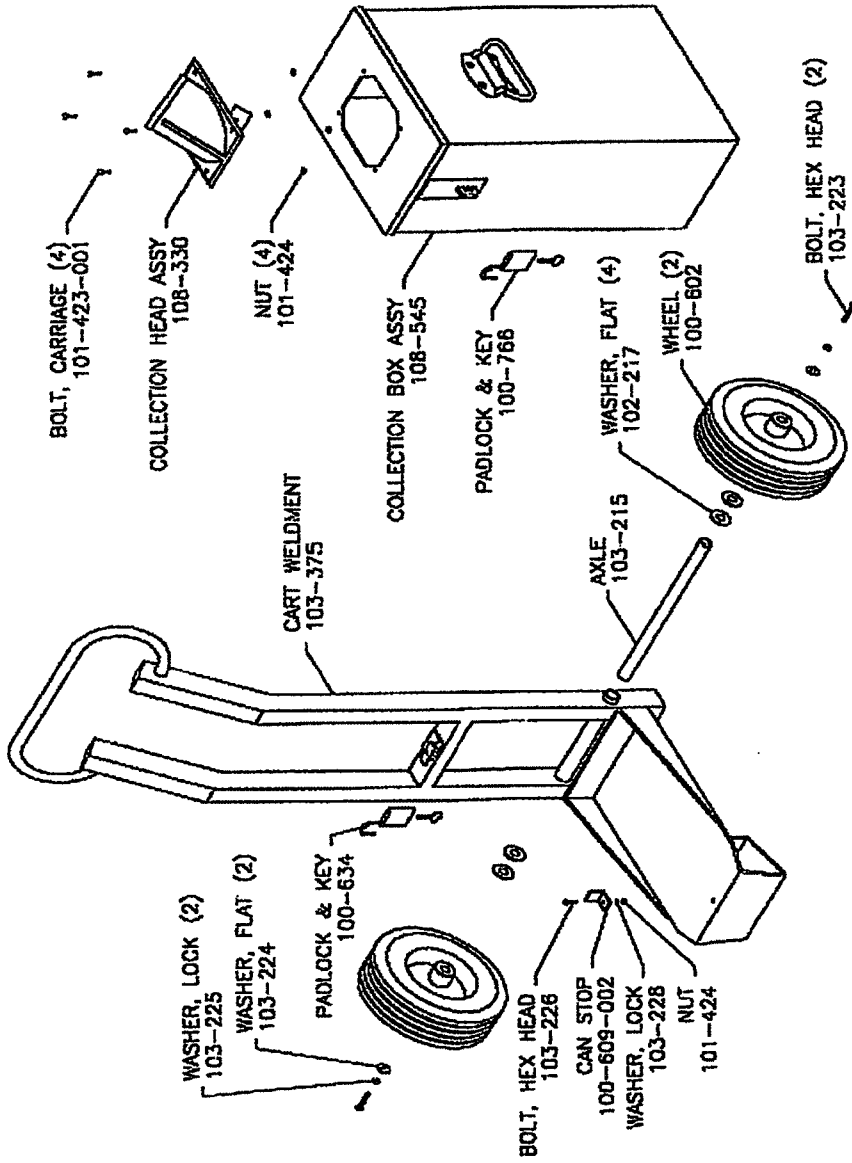

POM INCORPORATED
RUSSELLVILLE, AR

SECRETARY
6782/215 J01

POM Parts for Coin Cart Assembly, Prices Effective June 1, 2012.

Part No.	Description
100-602	Wheel
100-609-002	Can Stop
100-634	Padlock and 2 keys
100-766	Padlock and 2 keys
101-423-001	Bolt, Carriage
101-424	Nut
102-217	Washer, Flat
103-215	Axle
103-223	Bolt, Hex head
103-224	Flat Washer
103-225	Lock Washer
103-226	Bolt, Hex head
103-228	Washer, Lock
103-375	Cart Weldment
108-330	Collection Head Assembly, specify code
108-465	Collection Canister with Collection Head Assembly, specify code
108-545	Collection Canister, with Hasp, lid, and handles, 8x11x20-1/8

Price Ea.

\$ 82.15

\$ 6.00

\$ 13.00

\$ 22.89

\$ 0.18

\$ 0.18

\$ 0.35

\$ 26.31

\$ 0.25

\$ 0.14

\$ 0.15

\$ 0.10

\$ 0.10

\$ 508.00

\$ 350.00

\$ 677.73

\$ 410.12

POM INC, RUSSELLVILLE, AR, USA

108-330 COIN COLLECTION HEAD ASSY

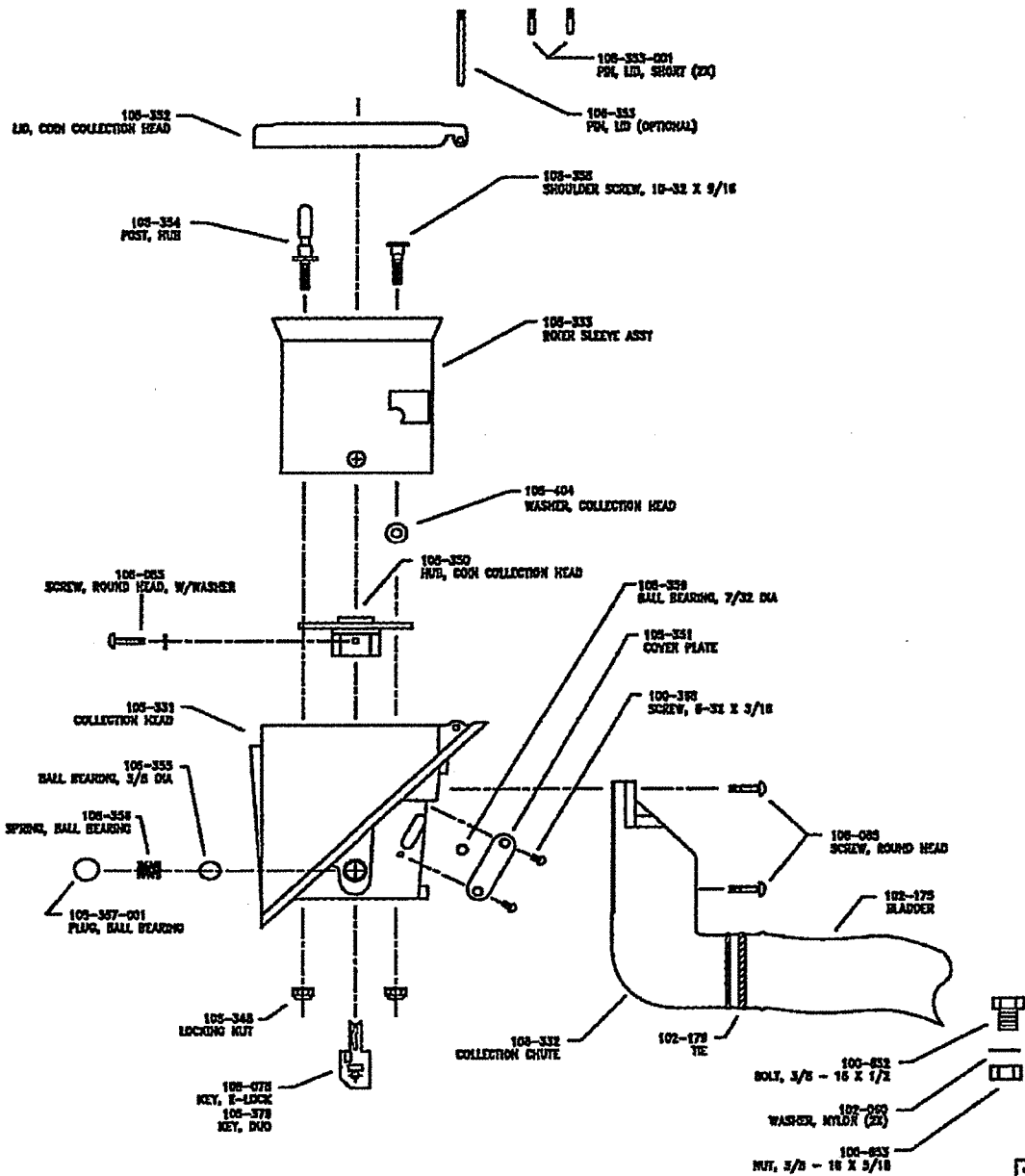

ISSUED BY THE ENGINEER
22 FEB 80/101

SCHEDULE B

SECTION IV

HOLD HARMLESS AGREEMENT AND INDEMNIFICATION CLAUSE AND INSURANCE REQUIREMENTS

Hold Harmless and Indemnification Clause

All insurance requirements including performance and payment bonds shall be furnished the day a contract issued pursuant to this Proposal is awarded.

The Contractor shall indemnify, hold harmless, and defend the Louisville/Jefferson County Metro Government, its elected and appointed officials, employees, agents and successors in interest from all claims, damages, losses and expenses including attorneys' fees, arising out of or resulting, directly or indirectly, from the Contractor's (or Contractor's Subcontractors, if any) performance or breach of the contract provided that such claim, damage, loss, or expense is: (1) attributable to personal injury, bodily injury, sickness, death, or to injury to or destruction of property, including the loss of use resulting therefrom, or breach of contract, and (2) not caused by the negligent act or omission or willful misconduct of the Louisville/Jefferson County Metro Government or its elected and appointed officials and employees acting within the scope of their employment. This Hold Harmless and Indemnification Clause shall in no way be limited by any financial responsibility or insurance requirements and shall survive the termination of this Contract.

INSURANCE REQUIREMENTS

Prior to award of contract and commencing work, Contractor shall obtain at its own cost and expense the following types of insurance through insurance companies licensed in the State of Kentucky. Insurance written by non-admitted carriers will also be considered acceptable, in accordance with Kentucky Insurance Law (KRS 304.10-040). Workers' Compensation written through qualified group self-insurance programs in accordance with Kentucky Revised Statutes (KRS 342.350) will also be acceptable. The Contractor shall not commence work under this Contract until all insurance required under the Contract Document has been obtained and until copies of policies or certificates thereof are submitted to **Louisville/Jefferson County Metro Government's Purchasing Division** and approved by the Louisville/Jefferson County Metro Government's Risk Management Division. The Contractor shall not allow any subcontractor to commence work until the insurance required of such subcontractor has been obtained and copies of Certificates of Insurance retained by Contractor evidencing proof of coverages.

Without limiting Contractor's indemnification requirements, it is agreed that Contractor shall maintain in force at all times during the performance of this agreement the following policy or policies of insurance covering its operations, and require subcontractors, if subcontracting is authorized, to procure and maintain these same policies until final acceptance of the work by the Louisville/Jefferson County Metro Government (Metro). Metro may require Contractor to supply proof of subcontractor's insurance via Certificates of Insurance, or at Metro's option, actual copies of policies.

- A. The insurance to be procured and maintained and **minimum** Limits of Liability shall be as follows, unless different limits are specified by addendum to the contract (and such

minimum limits shall not limit access to the full amount of insurance available (whether through primary, excess or umbrella policies) on Contractor's or subcontractors policy(ies), if that/those policy(ies) provide for Limits above the minimum):

1. **COMMERCIAL GENERAL LIABILITY**, via the **Occurrence Form**, primary, non contributory ,with a **\$1,000,000** Combined Single Limit for any one Occurrence and **\$2,000,000** aggregate for Bodily Injury, Personal Injury, Property Damage, and Products/Completed Operations including:
 - a. Premises - Operations Coverage
 - b. Products and Completed Operations
 - c. Contractual Liability
 - d. Broad Form Property Damage
 - e. Independent Contractors Protective Liability
 - f. Personal Injury

2. **WORKERS' COMPENSATION (IF APPLICABLE)** insuring the employers' obligations under Kentucky Revised Statutes Chapter 342 at Statutory Limits, and **EMPLOYERS' LIABILITY - \$100,000** Each Accident/**\$500,000** Disease - Policy Limit/**\$100,000** Disease - Each Employee.

ACCEPTABILITY OF INSURERS

Insurance is to be placed with Insurance Companies with an A. M. Best Rating of no less than "A- VI", unless proper financial information relating to the Company is submitted to and approved by Metro's Risk Management Division.

MISCELLANEOUS

- A. The Contractor shall procure and maintain insurance policies as described herein and for which the **Louisville/Jefferson County Metro Government's Purchasing Division** shall be furnished Certificates of Insurance upon the execution of the Contract. The Certificates shall include the name and address of the person executing the Certificate of Insurance as well as the person's signature. If policies expire before the completion of the Contract, renewal Certificates of Insurance shall be furnished to Metro at least fifteen (15) days prior to the expiration of any policy(s).

- B. **Upon execution of the contract, Certificates of Insurance as required above shall be furnished to:**

Louisville/Jefferson County Metro Government
Purchasing Division
611 West Jefferson Street
Louisville, KY 40202

- C. **Upon Renewal of insurance coverage (s), Certificates of Insurance evidencing renewal shall be furnished to:**

Louisville/Jefferson County Metro Government
Office of Management and Budget
Risk Management Division
611 West Jefferson Street
Louisville, Kentucky 40202

- D. **CANCELLATION OR MATERIAL CHANGE OF COVERAGE: Contractor shall notify Metro's Risk Management Division of any policy cancellation within thirty (30) business days of its receipt of same. Upon any material change (changes that reduce/restrict limit or terms and conditions to your insurance coverage) in coverage as required above, Contractor shall notify Metro's Risk Management Division within thirty (30) business days. If Contractor fails to notify Metro as required by this Agreement, Contractor agrees that such failure shall be a breach of this Agreement. Metro reserves the right to require the insurance policy(s) required above to be specifically endorsed to provide notice of cancellation and/or material change of coverage in accordance with policy provisions. When requested by the Metro Government, a copy of the policy endorsement shall be provided to Metro's Risk Management Division.**
- E. Approval of the insurance by Metro shall not in any way relieve or decrease the liability of the Contractor hereunder. It is expressly understood that Metro does not in any way represent that the specified Limits of Liability or coverage or policy forms are sufficient or adequate to protect the interest or liabilities of the Contractor.